

CITY COUNCIL MEETING

MUNICIPAL COMPLEX, EILEEN DONDERO FOLEY COUNCIL CHAMBERS, PORTSMOUTH, NH
DATE: MONDAY, JANUARY 9, 2023 TIME: 5:00PM

Members of the public also have the option to join the meeting over Zoom, a unique meeting ID and password will be provided once you register. To register, click on the link below or copy and paste this into your web browser:

https://us06web.zoom.us/webinar/register/WN_G9fgz1GOStaSsujfPJamfg

5:00PM – ANTICIPATED NON-PUBLIC SESSIONS ARE BEING HELD IN CONFERENCE ROOM A

1. PROPOSED MEMORANDUM OF AGREEMENT FOR PORTSMOUTH SCHOOL CUSTODIAL SUPERVISORS – RSA 91-A:3, II (a)(c) and (l)
2. PROPOSED MEMORANDUM OF AGREEMENTS FOR DISPATCHERS/LEAD DISPATCHERS AND PARAEDUCATORS – RSA 91-A:3, II (a)(c) and (l)
3. PROPOSED COLLECTIVE BARGAINING AGREEMENT WITH 1386B – RSA 91-A:3, II (a)(c) and (l)
4. CONSIDERATION OF LEGAL ADVICE – RSA 91-A:3, II (l)

AGENDA

**Regular portion of City Council meeting to begin at 7:00 p.m.*

- I. **WORK SESSION – THERE IS NO WORK SESSION THIS EVENING**
- II. **PUBLIC DIALOGUE SESSION** [when applicable – every other regularly scheduled meeting] – **N/A**
- III. **CALL TO ORDER** [7:00 p.m. or thereafter]
- IV. **ROLL CALL**
- V. **INVOCATION**
- VI. **PLEDGE OF ALLEGIANCE**
- VII. **ACCEPTANCE OF MINUTES** – *(There are no minutes on for acceptance this evening)*
- VIII. **RECOGNITIONS AND VOLUNTEER COMMITTEE REPORTS**
 1. *Winners of 2022 Holiday Lights Contest
 2. *Presentation by Rotary Past President, Ben Wheeler
 3. Recognition of Dave Lovely selected as the 2022 EPA Regional Wastewater Treatment Plant Operator of the Year Award
 4. *Recognition of Timothy Metivier selected as 2022 New Hampshire Code Official of the Year Award
- IX. **PUBLIC COMMENT SESSION** *(This session shall not exceed 45 minutes) – (participation may be in person or via Zoom)*

X. PUBLIC HEARINGS AND VOTE ON ORDINANCES AND/OR RESOLUTIONS

First Reading of Ordinance:

- A. First reading of Ordinance amending Chapter 7, Article IVA, Section 7A.408 – Taxi Stands Designated

Public Hearings of Ordinance and Adoption of Resolution:

- B. Public Hearing/Second reading of Ordinance amending Chapter 1, Article IV, Section 1.408 – Cable Television and Communications Commissions to be named Cable and Broadband Internet Commission
- **PRESENTATION**
 - **CITY COUNCIL QUESTIONS**
 - **PUBLIC HEARING SPEAKERS**
 - **ADDITIONAL COUNCIL QUESTIONS AND DELIBERATIONS**

(Sample motion – move to pass second reading and schedule a third and final reading at the January 23, 2023 City Council meeting)

- C. Public Hearing/Adoption of Resolution Authorizing a Supplemental Appropriation from the Unassigned Fund Balance for the Design and Engineering of Alternate Plans for the Redevelopment of McIntyre Federal Building and Surrounding Property. The City Council has determined that the sum of One Hundred Fifty Thousand (\$150,000.00) Dollars is to be appropriated from Unassigned Fund Balance to defray the expenditures for the design and engineering of alternate plans for the redevelopment of McIntyre Federal Building and surround property for the Fiscal Year ending in June 30, 2023
- **PRESENTATION**
 - **CITY COUNCIL QUESTIONS**
 - **PUBLIC HEARING SPEAKERS**
 - **ADDITIONAL COUNCIL QUESTIONS AND DELIBERATIONS**

(Sample motion – move to adopt the resolution as presented) (Two-thirds vote required for adoption)

XI. CITY MANAGER’S ITEMS WHICH REQUIRE ACTION

A. CITY MANAGER CONARD

City Manager’s Items Which Require Action:

1. Amendment to Public Art Funds Ordinance
2. Temporary Construction License for 64 Vaughan Street
3. Easements for Hope for Tomorrow Foundation

XII. CONSENT AGENDA

(Proper Motion for Adoption of Consent Agenda – move to adopt the Consent Agenda)

- A. Letter from Maria Stephanou, NH Walk Manager, requesting permission to hold the annual Seacoast Walk to End Alzheimer's on Sunday, October 1, 2023 **(Anticipated action – move to refer to the City Manager with Authority to Act)**
- B. Letter from Debra Smith, Friends of the South End, requesting permission to hold the annual Fairy House Tour on Saturday, September 23, 2023 and Sunday, September 24, 2023 **(Anticipated action – move to refer to the City Manager with Authority to Act)**
- C. Letter from Evan Dolecki, New England Ventures Endurance, requesting permission to hold the 2023 Margarita Half Marathon & 5k on Sunday, April 30, 2023 **(Anticipated action – move to refer to the City Manager with Authority to Act)**
- D. Request from Mark McNabb, Hearth Food Garden, LLC, to install a Projecting Sign at 60 Penhallow Street **(Anticipated action – move to approve the aforementioned Projecting Sign License as recommended by the Planning Director, and further, authorize the City Manager to execute the License Agreement for this request)**

Planning Director's Stipulations:

- *The license shall be approved by the Legal Department as to content and form;*
 - *Any removal or relocation of projecting sign, for any reason, shall be done at to the City; and*
 - *Any disturbance of a sidewalk, street or other public infrastructure resulting from the installation, relocation or removal of the projecting sign, for any reason shall be restored at no cost to the City and shall be subject to review and acceptance by the Department of Public Works*
- E. Request from Mark McNabb, River Wharf Hospitality, to install a Projecting Sign at 60 Penhallow Street **(Anticipated action – move to approve the aforementioned Projecting Sign License as recommended by the Planning Director, and further, authorize the City Manager to execute the License Agreement for this request)**

Planning Director's Stipulations:

- *The license shall be approved by the Legal Department as to content and form;*
- *Any removal or relocation of projecting sign, for any reason, shall be done at to the City; and*
- *Any disturbance of a sidewalk, street or other public infrastructure resulting from the installation, relocation or removal of the projecting sign, for any reason shall be restored at no cost to the City and shall be subject to review and acceptance by the Department of Public Works*

XIII. PRESENTATIONS AND WRITTEN COMMUNICATIONS

- A. Email Correspondence (*Sample motion – move to accept and place on file*)
- B. Letter from Perry Silverstein requesting the City not favor one industry over others regarding outdoor dining (*Sample motion – move to accept and place on file*)

XIV. MAYOR McEACHERN

1. *Appointments to be Voted:
 - Reappointment of Dana Levenson to the Trustee of the Trust Funds
 - Reappointment of Phyllis Eldridge to the Zoning Board of Adjustment
 - Appointment of Alan Cohen to the Task Force to Study Private/Public Historical Archives Committee
 - Appointment of Jeff Keefe to the Task Force to Study Private/Public Historical Archives Committee

XV. CITY COUNCIL MEMBERS

A. COUNCILOR TABOR

1. *January 25th Budget Kickoff (*Sample motion – move for a report back on preliminary FY24 trends, major budget drivers, potential tax impacts and city manager guidelines at January 25, 2023 council budget kickoff work session*)
2. *Selection of an Auditor (*Sample motion #1 – move to unseal that portion of the City Council’s non-public session meeting minutes dated December 14, 2022 relative to the selection of an auditor only*) (*Sample motion #2 – move to select an audit firm*)

B. COUNCILOR DENTON

1. *Outdoor Dining (*Sample motion – move for all restaurants with outdoor dining that successfully compost to pay 2022 outdoor dining rates*)
2. *E-mail Addresses (*Sample motion – move for all members of the City Council to be given municipal e-mail addresses for official business*)

C. COUNCILOR BAGLEY & COUNCILOR COOK

1. *2023 Outdoor Dining Season – *In order to encourage outdoor dining and increase vibrancy in downtown Portsmouth, we: (Sample motion #1 - move to adopt an outdoor dining policy in Portsmouth with the following parameters:*
 - a. *Outdoor dining will commence for parking/loading zone encumbered dining starting on May 1 and ending on Indigenous Peoples’ Day. The City of Portsmouth will do everything possible to place and remove barriers within 10 working days following the beginning and end of the parking/loading zone dining season. Sidewalk dining will be allowed as the weather permits, but sidewalk encumbrances should be removed so as not to interfere with sidewalk snow removal, with penalty of fine should removal not take place prior to a snowstorm. Yearly permitting for sidewalk dining will take place in March. Applications for all outdoor dining will be accepted starting February 15, with a deadline of April 1.*

- b. Outdoor dining shall not encumber street flow of traffic in the high traffic zones of the downtown area. Exceptions shall only be permitted by appeal to the City Manager, with evidence of traffic flow below 1000 cars per day.**
- c. Outdoor dining in parking/loading zones shall follow a uniform appearance with City-placed concrete barriers and planter boxes as described in the December 22 City Report, and wooden platforms to allow for uniform accessibility. Restaurants with existing platforms and surrounds designed for prior seasons shall be grandfathered-in with permission of the City Manager. All outdoor dining spaces shall have tables and separate chairs to allow for uniform accessibility. When requiring a divider from sidewalk flow, sidewalk dining shall require either a metal or metal-looking barrier, or a rope-like barrier for separation.**
- d. Parking/Loading zone outdoor dining shall have a permit fee of \$1500/space or \$10/square foot, whichever is a lesser expense. Any restaurant taking up a parking space must pay for the full square footage of the parking space, or the standard space fee. Sidewalk encumbrance shall have a flat fee of \$500/season with sidewalk encumbrance (space) limitations determined by the City Manager.**
- e. Restaurants requesting a parking/loading zone encumbrance can receive up to a \$500 reduction in fees if they compost food waste. For sidewalk spaces, restaurants may receive up to a \$200 reduction in fees if they compost food waste.**
- f. The City Manager has the authority to act with notification of the Council if any unforeseen circumstances occur or unexpected adjustments are needed.**

(Sample motion #2 - move to include the downtown area bounded by Deer Street, the Piscataqua River, Prescott Park, Court Street, and Maplewood Avenue/Middle Street in the redesign of Market Square in 2023 with the goal of enhanced pedestrian access with expanded sidewalks, expanded sidewalk dining throughout downtown and reduced traffic congestion, including possible redesign of traffic flow (two-way traffic) on State Street)

XVI. APPROVAL OF GRANTS/DONATIONS

- A. Acceptance of Donation to the Tree Fund from Judith A. Sabin - \$25.00 (Sample motion – move to approve and accept the donation as presented)**
- B. Acceptance of Donation to the Fire Department from Paul Gormley & Kimi Iguchi for the Discretion of the Fire Department - \$2,500.00 (Sample motion – move to approve and accept the donation as presented)**
- C. Acceptance of Donation to the Senior Activity Center from Anne Aoki for Senior Luncheon Funds - \$5,000.00 (Sample motion – move to approve and accept the donation as presented)**
- D. *Approval and Acceptance of NH Department of Safety, Division of Homeland Security and Emergency Management - Emergency Management Performance Grant (EMPG) - \$5,500.00 (Sample motion – move to approve and accept the grant as presented)**

XVII. CITY MANAGER'S INFORMATIONAL ITEMS

(There are no items under this Section of the Agenda this evening)

XVIII. MISCELLANEOUS BUSINESS INCLUDING BUSINESS REMAINING UNFINISHED AT PREVIOUS MEETING

XIX. ADJOURNMENT [at 10:30 p.m. or earlier]

**Indicates verbal report*

**KELLI L. BARNABY, MMC/CNHMC
CITY CLERK**



UNITED STATES ENVIRONMENTAL PROTECTION AGENCY
Region 1
5 Post Office Square, Suite 100
BOSTON, MA 02109-3912

December 14, 2022

Mr. David Lovely, Chief Plant Operator
Pease WWTP, City of Portsmouth, NH
680 Peverly Hill Rd
Portsmouth, NH 03801

Dear Mr. Lovely:

On behalf of the United States Environmental Protection Agency (EPA) Region 1 Office, I am pleased to inform you that you have been selected as a recipient of the **2022 Regional Wastewater Treatment Plant Operator of the Year Award**. You were nominated by the New Hampshire Department of Environmental Services to acknowledge your work in the field of wastewater treatment. Congratulations on this accomplishment!

You are cordially invited **to attend the annual New England Water Environment Association (NEWEA) Awards Luncheon on Wednesday, January 25, 2023, from 11:00AM - 1:00PM at the Boston Marriott Hotel/Copley Place**. During the luncheon you will be recognized as one of the 2022 Regional EPA Award recipients. One complimentary luncheon ticket will be reserved in your name. If additional tickets are necessary, they may be purchased through NEWEA at www.newea.org.

If possible, we ask that you arrive between 9:00AM and 9:30AM on the day of the Awards Luncheon and report to a designated room for photos. Due to the large number of awards that will be announced and presented during the luncheon itself, this may be the only time set aside for formal picture taking.

Please contact Jay Pimpare at (617) 918-1531 or Pimpare.justin@epa.gov on whether you will be able to attend the ceremony or should you have any additional questions.

Once again, EPA would like to congratulate you on being selected as a 2022 Regional EPA award recipient.

Sincerely,



Jason Turgeon
Municipal Assistance Unit

cc:

Peter Rice, Director of Public Works

Karen Conard, Town Administrator

John Adie, New Hampshire Department of Environmental Services

Dick Emberley, New Hampshire Department of Environmental Services

Tracy Wood, New Hampshire Department of Environmental Services

Mark Spinale, EPA

Justin Pimpare, EPA

ORDINANCE #

THE CITY OF PORTSMOUTH ORDAINS

That Chapter 7, Article IVA, Section 7A.408 – **TAXI STANDS DESIGNATED** of the Ordinances of the City of Portsmouth be amended as follows (deletions from existing language **stricken**; additions to existing language **bolded**; remaining language unchanged from existing):

ARTICLE IVA: BUS STOPS AND TAXICAB STANDS

Section 7A.408: TAXI STANDS DESIGNATED

The following areas are hereby designated as Taxi stands:

~~A. Hanover Street: southerly side, first parking space west from Fleet Street from 7:00 p.m. to 6:00 a.m.~~

~~B. Market Street:~~

- ~~1. easterly side, second parking space from Market Square.~~
- ~~2. easterly side, south for a distance of 40 feet, beginning at Bow Street, from 7 p.m. to 6 a.m., Monday through Sunday~~

~~C.A.~~ Pleasant Street: easterly side, first parallel parking space north of State Street.

~~D. State Street: northerly side, 40 feet from Pleasant Street for a distance of 20 feet, from 7 p.m. to 6 a.m., Monday through Sunday~~

The City Clerk shall properly alphabetize and/or re-number the ordinances as necessary in accordance with this amendment.

All ordinances or parts of ordinances inconsistent herewith are hereby deleted.

This ordinance shall take effect upon its passage.

APPROVED:

Deaglan McEachern, Mayor

ADOPTED BY COUNCIL:

Kelli L. Barnaby, City Clerk

LEGAL NOTICE

NOTICE IS HEREBY GIVEN that a Public Hearing will be held by the Portsmouth City Council on Monday, January 9, 2023 at 7:00 p.m., at the Portsmouth Municipal Complex in the Eileen Dondero Foley Council Chambers, Portsmouth, NH, on the proposed Ordinance amending Chapter 1, Article IV, Section 1.408 – Cable Television and Communications Commission to be named Cable and Broadband Internet Commission. The complete Ordinance is available for review in the Office of the City Clerk and Portsmouth Public Library, during regular business hours.

KELLI L. BARNABY, MMC/CNHMC
CITY CLERK

Seacoastonline

Public Notices

Originally published at seacoastonline.com on 12/18/2022

LEGAL NOTICE

NOTICE IS HEREBY GIVEN that a Public Hearing will be held by the Portsmouth City Council on Monday, January 9, 2023 at 7:00 p.m., at the Portsmouth Municipal Complex in the Eileen Dondero Foley Council Chambers, Portsmouth, NH, on the proposed Ordinance amending Chapter 1, Article IV, Section 1.408 – Cable Television and Communications Commission to be named Cable and Broadband Internet Commission. The complete Ordinance is available for review in the Office of the City Clerk and Portsmouth Public Library, during regular business hours.

KELLI L. BARNABY, MMC/CNHMC
CITY CLERK

ORDINANCE #

THE CITY OF PORTSMOUTH ORDAINS

That Chapter 1, Article IV, Section 1.408 of the Ordinances of the City of Portsmouth be amended as follows (deletions from existing language **stricken**; additions to existing language **bolded**; remaining language unchanged from existing):

Section 1.408: CABLE **TELEVISION** AND **COMMUNICATIONS** BROADBAND INTERNET COMMISSION

A. Membership, Qualifications, Tenure: The Cable Television and Communications Commission shall consist of five (5) commissioners and one alternate commissioner appointed by the Mayor subject to confirmation by the City Council. Of the initial appointments, three shall be of three (3) years and two shall be for two (2) years. Thereafter, all appointments including the alternate commissioner shall be for a term of three years. The alternate commissioner shall attend all Commission meetings and may vote at any time when there are less than five commissioners otherwise voting.

Commissioners shall be residents of the City of Portsmouth at the time and during the terms of their appointments. Commissioners shall be familiar with the general concepts underlying the operation of cable television **as well as the delivery of broadband internet services via multiple physical transport methods.**

B. The Commission shall have the authority to establish standing sub-committees on matters pertaining to the operation and performance of cable **and broadband internet** companies within the City.

Such subcommittees shall serve in an advisory capacity to the Cable **and Broadband Internet** Commission. ~~In the first instance, the standing Sub-committees shall consist of:~~

~~Government/Education Access Channels, I-Net System and Customer Service. The Commission shall have the right to appoint non-Commission members to subcommittees; when possible, the Commission shall attempt to use Portsmouth residents for such appointments. If the Commission wishes to appoint a non-Portsmouth resident who has skills helpful to the Commission's work; the Commission shall have the authority to make such an appointment.~~

C. Powers: ~~In addition to establishing the standing Sub-Committees referenced above, the Commission shall have the authority to eliminate such Sub-Committees and create new ones as the Commission deems appropriate~~ The Commission shall oversee the operation of the existing Cable Television Franchise Agreement and any future agreements, which the City Council may approve **as well as assist in the negotiation of such agreements. The Commission may, as the need arises, consider the availability and quality of Broadband Internet services delivered via any physical**

transport (which includes physical cabling or over-the-air delivery) and work to understand the needs and desires of the citizens of the city of Portsmouth. Further, the committee may work with relevant providers to meet those needs and desires as appropriate and as guided by the City Council.

D. The Commission shall meet as often as deemed appropriate and necessary to insure the proper operation of the Franchise Agreement. The Commission shall, upon request of the City Council, submit written or verbal reports of its activities.

The City Clerk shall properly alphabetize and/or re-number the ordinances as necessary in accordance with this amendment.

All ordinances or parts of ordinances inconsistent herewith are hereby deleted.

This ordinance shall take effect upon its passage.

APPROVED:

Deaglan McEachern, Mayor

ADOPTED BY COUNCIL:

Kelli L. Barnaby, City Clerk

LEGAL NOTICE

NOTICE IS HEREBY GIVEN that a Public Hearing will be held by the Portsmouth City Council on Monday, January 9, 2023 at 7:00 p.m., at the Portsmouth Municipal Complex in the Eileen Dondero Foley Council Chambers, Portsmouth, NH, on a proposed Resolution Authorizing a Supplemental Appropriation from the Unassigned Fund Balance for the Design and Engineering of Alternate Plans for the Redevelopment of McIntyre Federal Building and Surrounding Property. The City Council has determined that the sum of One Hundred Fifty Thousand (\$150,000.00) Dollars is to be appropriate from Unassigned Fund Balance to defray the expenditures for the design and engineering of alternate plans for the redevelopment of McIntyre Federal Building and surround property for the Fiscal Year ending in June 30, 2023. The complete Resolution is available for review in the Office of the City Clerk and Portsmouth Public Library, during regular business hours.

KELLI L. BARNABY, MMC/CNHMC
CITY CLERK

Seacoastonline

Public Notices

Originally published at seacoastonline.com on 12/18/2022

LEGAL NOTICE

NOTICE IS HEREBY GIVEN that a Public Hearing will be held by the Portsmouth City Council on Monday, January 9, 2023 at 7:00 p.m., at the Portsmouth Municipal Complex in the Eileen Dondero Foley Council Chambers, Portsmouth, NH, on a proposed Resolution Authorizing a Supplemental Appropriation from the Unassigned Fund Balance for the Design and Engineering of Alternate Plans for the Redevelopment of McIntyre Federal Building and Surrounding Property. The City Council has determined that the sum of One Hundred Fifty Thousand (\$150,000.00) Dollars is to be appropriate from Unassigned Fund Balance to defray the expenditures for the design and engineering of alternate plans for the redevelopment of McIntyre Federal Building and surround property for the Fiscal Year ending in June 30, 2023. The complete Resolution is available for review in the Office of the City Clerk and Portsmouth Public Library, during regular business hours.

KELLI L. BARNABY, MMC/CNHMC

CITY CLERK

**CITY OF PORTSMOUTH, NEW HAMPSHIRE
SUPPLEMENTAL APPROPRIATION
FOR THE FISCAL YEAR ENDING JUNE 30, 2023**

RESOLUTION # -

A RESOLUTION AUTHORIZING A SUPPLEMENTAL APPROPRIATION FROM THE UNASSIGNED FUND BALANCE FOR THE DESIGN AND ENGINEERING OF ALTERNATE PLANS FOR THE REDEVELOPMENT OF MCINTYRE FEDERAL BUILDING AND SURROUNDING PROPERTY.

RESOLVED:

BY THE CITY COUNCIL OF THE CITY OF PORTSMOUTH, NEW HAMPSHIRE ASSEMBLED AS FOLLOWS:

THAT, the City Council has determined that the sum of ONE Hundred Fifty Thousand (\$150,000) Dollars is to be appropriated from Unassigned Fund Balance to defray the expenditures for the design and engineering of alternate plans for the redevelopment of McIntyre Federal Building and surrounding property for the Fiscal Year ending in June 30, 2023.

THAT, to meet this appropriation, the City Manager is authorized to transfer these funds from Unassigned Fund Balance.

APPROVED BY:

**_____
DEAGLAN MCEACHERN, MAYOR**

ADOPTED BY THE CITY COUNCIL:

**_____
KELLI BARNABY, MMC/CNHMC
CITY CLERK**

SECTION 7.14-AMENDMENTS TO BUDGET AFTER ADOPTION

No appropriation shall be made for any purpose not included in the annual budget as adopted unless voted by a two-thirds (2/3) majority of the Council after a public hearing held to discuss said appropriation. The Council shall, by resolution, designate the source of any money so appropriated.



CITY OF PORTSMOUTH

City Hall, One Junkins Avenue
Portsmouth, New Hampshire 03801
kconard@cityofportsmouth.com
(603) 610-7201

Karen S. Conard
City Manager

Date: January 5, 2023

To: Honorable Mayor McEachern and City Council Members

From: Karen S. Conard, City Manager *KSC*

Re: City Manager's Comments on City Council Agenda of January 9, 2023

X. Public Hearings and Votes on Ordinances and/or Resolutions:

A. First Reading of Ordinance Amending Chapter 7, Article IVA, Section 7A.408 – Taxi Stands Designated:

For first reading this evening is an [amendment to the Chapter 7, Article IVA, Section 7A.408, Taxi Stands Designated Ordinance](#). By way of background, the City Council requested the Parking and Traffic Safety Committee (PTSC) report back on the use of taxi stands reserved throughout the City. At its October 6, 2022 meeting, PTSC members relayed that staff had reached out to the one remaining taxi company left in the City. The owner requested that one taxi stand located at Pleasant Street remain in use. PTSC voted unanimously to remove all taxi stands throughout the City, except the one on Pleasant Street. The City Council approved this action and the PTSC minutes at its December 5, 2022 meeting.

Because the taxi stands are listed in the ordinance, this action requires an amendment to Chapter 7, Article IVA, Section 7A.408, Taxi Stands Designated. Consequently, this is being brought forward for first reading.

I recommend that the City Council move to pass first reading and schedule a second reading and Public Hearing at the January 23, 2023 City Council meeting.

B. Public Hearing and Second Reading of Ordinance Amending Chapter 1, Article IV, Section 1.408 - Cable Television and Communications Commission to be named Cable and Broadband Internet Commission:

The Cable Commission requests that the City Council consider [proposed changes to Chapter 1, Article IV, Section 1.408](#) currently titled Cable Television and Communications Commission. The Commission proposes changes to their title and powers to broaden their responsibility beyond cable television and to include broadband internet services via any physical transport method (including both physical cabling and over-the-air delivery such as cellular). See [attached proposed ordinance changes](#).

The Commission developed these proposed changes over the course of several meetings this year. The Cable Commission referred these proposed changes to the Governance Committee for review and input; the Governance Committee supported the Commission's desire to broaden their powers. Deputy City Manager/Deputy City Attorney Suzanne Woodland provides staff support for the Commission and has worked with them to develop these proposed changes. She will be available if there are questions this evening, along with a member of the Cable Commission.

I recommend that the City Council move to pass second reading and schedule a third and final reading at the January 23, 2023 City Council meeting.

C. **Public Hearing and Adoption of Resolution Authorizing a Supplemental Appropriation from the Unassigned Fund Balance for the Design and Engineering of Alternate Plans for the Redevelopment of the McIntyre Federal Building and Surrounding Property:**

In April of 2022, the City and SoBow Square, LLC (SoBow) executed a Settlement Agreement that resolved a law suit brought by SoBow against the City, related to the McIntyre project. Over the last seven months, the City, SoBow, and its partners completed a design for what is commonly referred to as the "Community Plan."

The preliminary cost estimates for construction of the Community Plan vary widely. As discussed at the December 5th City Council meeting, the City requested and was granted an extension of the License with (GSA) for the McIntyre building, and for the submission of its application to the National Park Service (NPS) for an additional ninety days.

During the next three months, the City will engage in discussions and negotiations with SoBow regarding the design, the division of capital contributions to the project, the division of the expected revenue returns, and other pending elements of the project. The City will contract with qualified consultants to assist in these negotiations.

The expected expenses are estimated to be up to \$50,000 per party per month. [A copy of the supplemental appropriation for \\$150,000](#) is attached and recommended to pay for these costs.

I recommend that the City Council move to adopt the resolution as presented.

XI. City Manager's Items which Require Action:

1. **Amendment to Public Art Funds Ordinance:**

[Attached please find a memorandum regarding an amendment to the Public Art Funds Ordinance.](#)

I recommend that the City Council move to place [the attached amended Funding of Public Art Ordinance, Chapter 1, Article XVII, Section 1.1705](#), on the City Council's next Agenda for First Reading.

2. **Temporary Construction License for 64 Vaughan Street:**

On August 19, 2021, the Planning Board granted site plan approval for renovation of the Margeson building and construction of an addition for property located at [64 Vaughan Street](#) (“Property”). The original site plan included retail and office space with underground parking, as well as sidewalks and improvements to the Worth Lot. The property was conveyed to Novocure Inc. in December of 2021. Novocure Inc. will use the 42,000 square foot building for their flagship North American headquarters.

The Construction Mitigation and Management Plan (CMMP), signed on November 16, 2021, identified temporary encumbrances for project-related work during the project’s construction. Encumbrances for a duration longer than 30 consecutive working days require a license approved by the City Council. All licenses are subject to the “License Fee for Encumbrance of City Property” policy.

On February 22, 2022, the City Council granted a license for this project for the use of 35 square feet of city property in the Vaughan Mall and 14 parking spaces in the Worth Lot from March 5, 2022 through June 3, 2022. The Council granted a second license to use 650 square feet of the alley that abuts the Property and connects Hanover Street to the Worth Lot to set a crane and ten (10) parking spaces in the Worth Lot from September 20, 2022 to January 1, 2023. The applicant has experienced delays due to changes in the project’s design and is [requesting a third license to encumber 10 parking spaces in the Worth Lot](#) from January 10th to April 1st (6 in the Worth Lot and 4 along the alley that connects to Hanover Street for a safety buffer) to complete exterior framing, the façade and roof.

The total License Fee for the ten (10) parking spaces in the Worth Lot is \$28,700 (\$35 per space x 10 = \$350 a day x 82 days).

The Legal and Planning Departments have reviewed and approved the form of [the attached License](#).

If the Council agrees to grant the temporary construction license to encumber ten (10) parking spaces in the Worth Lot, an appropriate motion would be:

Move that the City Manager be authorized to execute and accept the temporary construction license to encumber the use of ten (10) parking spaces in the Worth Lot for a term of 82 days as requested.

3. **Easements for Hope for Tomorrow Foundation:**

Before the City Council this evening are two easements related to the St. Patrick’s School located at 315 Banfield Road.

The first easement is for the City to grant to the Hope for Tomorrow Foundation (“HFT”), also commonly known as St. Patrick’s School, a sewer easement for existing sewer infrastructure across the City’s Community Campus parcel.

By way of background, on March 16, 2017, the Planning Board approved the construction of the school. Sewer service was to be provided by the construction of a new line from the HFT parcel to existing infrastructure (a pump station) on the abutting Community Campus parcel. The Foundation for Seacoast Health (“Foundation”) owned the Community Campus parcel prior to the City’s acquisition of the property in 2022 and entered into a Joint Operating Agreement with HFT to install the new sewer line and the Foundation agreed to grant a permanent easement once the line was installed with reference to as-built plans. The Foundation did not convey the easement to HFT prior to the transfer of the property to the City of Portsmouth, although all parties including the City were aware of the outstanding easement needed. [Drafts of the easement deed and plan to be recorded are included](#), but there may be minor amendments or edits to these documents prior to recording.

The second easement is to accept an easement from HFT to provide access to water infrastructure. On March 17, 2020, the Planning Board granted site plan approval for HFT to construct a gymnasium on its property. Private water infrastructure was installed and in order for the City to have convenient access to the infrastructure for inspection and leak detection purposes, an access easement in favor of the City was required. HFT mistakenly recorded this Access Easement for Water Service prior to City Council approval. [The Access Easement for Water Service attached](#) is being presented now for City Council approval.

I recommend that the City Council grant the City Manager the authority to both finalize and execute a sewer easement from the City to the Hope for Tomorrow Foundation, and to accept on behalf of the City the Access Easement for Water Service as presented.

XII. Consent Agenda:

D. Request from Mark McNabb, Hearth Food Garden, LLC, to Install a Projecting Sign at 60 Penhallow Street:

Permission is being sought to install a projecting sign at [60 Penhallow Street for Hearth Food Garden, LLC](#) that extends over the public right of way, as follows:

Sign dimensions: 42” diameter
Sign area: 9.6 sq. ft.

The proposed sign complies with zoning requirements. If a license is granted by the City Council, no other municipal approvals are needed. *Therefore, I recommend approval of a revocable municipal license, subject to the following conditions:*

- 1) The license shall be approved by the Legal Department as to content and form;*
- 2) Any removal or relocation of the sign, for any reason, shall be done at no cost to the City; and*
- 3) Any disturbance of a sidewalk, street or other public infrastructure resulting from the installation, relocation or removal of the signs, for any reason, shall be restored at no cost to the City and shall be subject to review and acceptance by the Department of Public Works.*

E. **Request from Mark McNabb, River Wharf Hospitality, to Install a Projecting Sign at 60 Penhallow Street:**

Permission is being sought to install a projecting sign at [60 Penhallow Street for River Wharf Hospitality](#) that extends over the public right of way, as follows:

Sign dimensions: 40” diameter

Sign area: 8.7 sq. ft.

The proposed sign complies with zoning requirements. If a license is granted by the City Council, no other municipal approvals are needed. *Therefore, I recommend approval of a revocable municipal license, subject to the following conditions:*

- 1) *The license shall be approved by the Legal Department as to content and form;*
- 2) *Any removal or relocation of the sign, for any reason, shall be done at no cost to the City; and*
- 3) *Any disturbance of a sidewalk, street or other public infrastructure resulting from the installation, relocation or removal of the signs, for any reason, shall be restored at no cost to the City and shall be subject to review and acceptance by the Department of Public Works.*

XVI. Approval of Grants/Donations:

A. **Acceptance of Donation to Tree Fund from Judith A. Sabin - \$25:**

[Attached please find a donation form from the Public Works Department](#) requesting acceptance of \$25 for the City’s Tree Fund from Judith A. Sabin.

I recommend that the City Council move to approve and accept the donation as presented.

B. **Acceptance of Donation to the Fire Department from Paul Gormley and Kimi Iguchi - \$2,500:**

[Attached please find a donation form from the Fire Department](#) requesting acceptance of \$2,500 from Paul Gormley and Kimi Iguchi.

I recommend that the City Council move to approve and accept the donation as presented.

C. **Acceptance of Donation to the Senior Activity Center from Anne Aoki - \$5,000:**

[Attached please find a donation form from the Recreation Department](#) requesting acceptance of \$5,000 from Anne Aoki.

I recommend that the City Council move to approve and accept the donation as presented.

D. **Acceptance of Grant for the Fire Department - \$5,500:**

The Fire Department is requesting acceptance of a grant from the NH Department of Safety in the amount of \$5,500 to update the City’s Emergency Operational Plan, which provides a framework for the City of Portsmouth and our partners to provide assistance to residents and

visitors in the event of a perceived, potential or actual emergency. This Plan was last updated in 2017.

The Emergency Operations Plan establishes policies and procedures, describes strategies, assumptions, objectives and how the City will support the five phases of Emergency Management: prevention, mitigation, preparedness/protection, and response and recovery across 15 functional areas which include transportation, communications and alerting, Public Works & Engineering, Firefighting, Emergency Management, mass care, housing and human services, resource support, health and medical, search and rescue, hazardous materials, agriculture, cultural and natural resources, energy, public safety and law enforcement, volunteer donation and management, and public information.

The grant would be used to hire a consultant to work with City Staff to update the current plan and make the relevant and necessary changes, and ensure compliance with State and Federal requirements.

I recommend that the City Council move to approve and accept the grant as presented.

**CITY OF PORTSMOUTH
LEGAL DEPARTMENT
MEMORANDUM**

DATE: JANUARY 3, 2023
TO: KAREN CONARD, CITY MANAGER
FROM: SUSAN G. MORRELL, CITY ATTORNEY
RE: AMENDMENT TO PUBLIC ART FUNDS ORDINANCE

Background

The City Council recently voted to approve the expenditure of \$21,100 from the Public Art Fund Trust to assist in funding the anticipated art project at Bohenko Park. This City Council approved expenditure was presented to the Trustees of the Trust Funds who manage all of the City’s Trust Funds to include the City of Portsmouth Public Art Trust. The terms of the Public Art Trust limit the use of the Trust’s assets. The terms of the Trust direct that “the assets and income held in the Public Art Trust may be expended for any public art purpose which is consistent with the public art ordinance of the City.” (Emphasis added.)

The City’s Art Ordinance, Chapter 1, Article XVII, Section 1.1705 (A), provides that “no less than ninety (90%) percent of the principal amount of public art contribution generated by any particular building project shall be expended on the site of that project.” Currently, there is \$21,100 in the Public Art Trust which represents the remainder of the City’s contribution of \$150,000 for public art at the Foundry Garage. The public art project at the Foundry Garage is now completed but it did not require the expenditure of the entire 90% of the principle amount contributed for the project.

However, the City’s Public Art Ordinance does not provide direction for the use of surplus funds in the Trust. Compliance with the ordinance prevents the Trustees from providing more than 10% of the original \$150,000 contribution to a different art project. That means that the Trust can only contribute \$15,000 to the Bohenko Park project even though the City Council authorized the expenditure of \$21, 100. There is no authority for the City Council or the Trustees of the Trust Funds to distribute the surplus of \$6, 100 in the Trust for the benefit of any other project even though it is not needed for the Foundry Garage project.

Proposed Amendment to the Funding of Public Art Ordinance

The City’s Art Ordinance did not contemplate a surplus of funds in the Trust after the completion of a project. However, this can be remedied with a simple amendment to the ordinance permitting the City Council to authorize the expenditure of surplus funds from the

Public Art Trust. The attached proposed amendment to the City's Funding of Public Art Ordinance accomplishes this goal.

Action

Move to place the attached amended Funding of Public Art Ordinance, Chapter 1, Article XVII, Section 1.1705, on the City Council's next Agenda for First Reading.

cc: Suzanne M. Woodland, Deputy City Manager/Deputy City Attorney

ORDINANCE #

THE CITY OF PORTSMOUTH ORDAINS

That Chapter 1, Article XVII, Section 1.1705 – **EXPENDITURE OF PUBLIC ART FUNDS** of the Ordinances of the City of Portsmouth be amended as follows (deletions from existing language **stricken**; additions to existing language **bolded**; remaining language unchanged from existing):

ARTICLE XVII: FUNDING OF PUBLIC ART

Section 1.1705: EXPENDITURE OF PUBLIC ART FUNDS

Expenditure of public art funds shall be determined by the City Council. In authorizing such expenditures the Council shall apply the following protocol and criteria:

- A. No less than ninety (90%) percent of the principal amount of public art contribution generated by any particular building project shall be expended on the site of that project, **unless the City Council votes specifically otherwise.**

(All other aspects of this Section shall remain unchanged.)

The City Clerk shall properly alphabetize and/or re-number the ordinances as necessary in accordance with this amendment.

All ordinances or parts of ordinances inconsistent herewith are hereby deleted.

This ordinance shall take effect upon its passage.

APPROVED:

Deaglan McEachern, Mayor

ADOPTED BY COUNCIL:

Kelli L. Barnaby, City Clerk

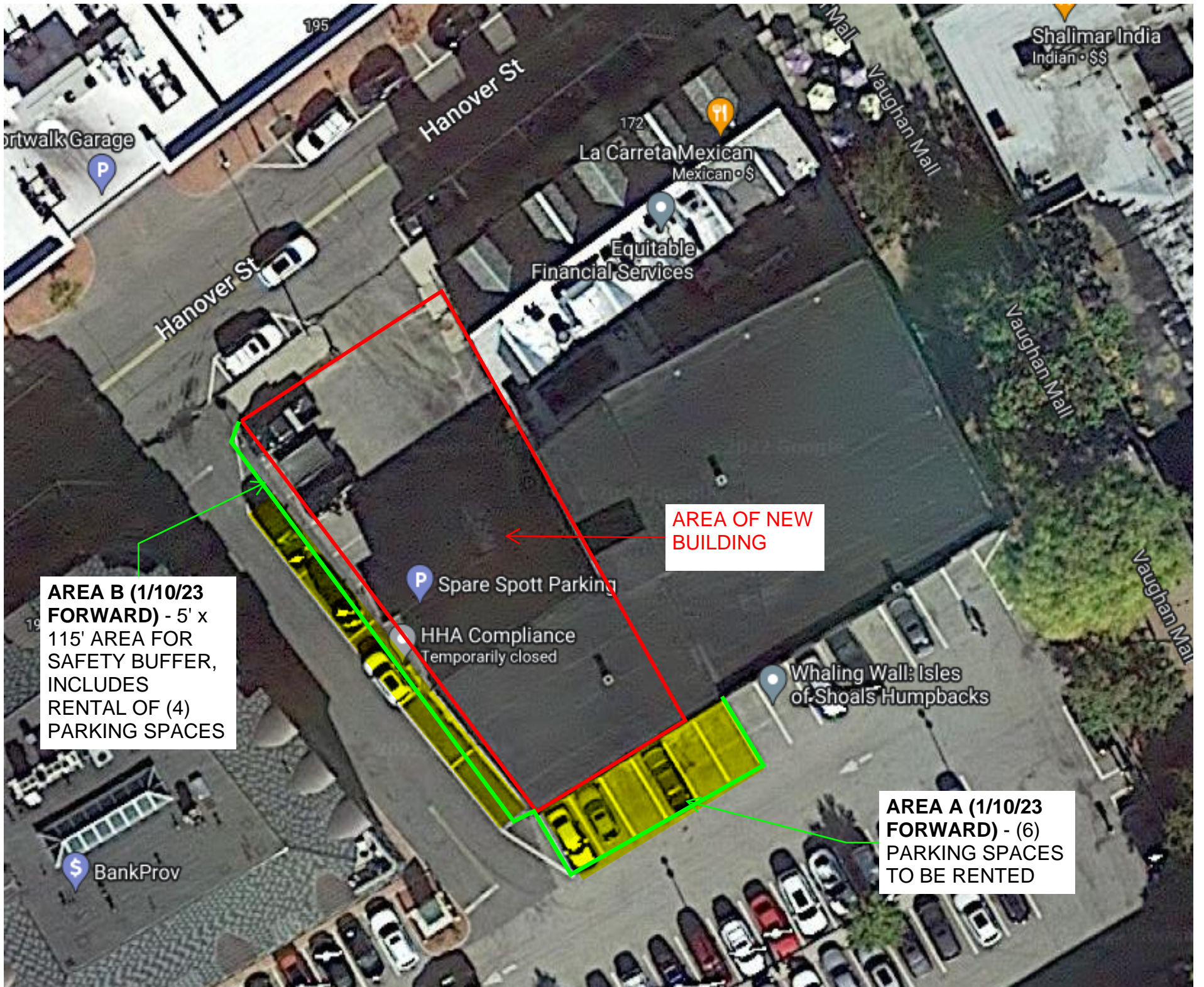

AREA OF NEW BUILDING

AREA B (1/10/23 FORWARD) - 5' x 115' AREA FOR SAFETY BUFFER, INCLUDES RENTAL OF (4) PARKING SPACES

AREA A (1/10/23 FORWARD) - (6) PARKING SPACES TO BE RENTED

HAMPSHIRE
DEVELOPMENT
CORPORATION

General Contractor

December 29, 2022

Attn: Portsmouth City Council
1 Junkins Ave.
Portsmouth, NH 03801

RE: 64 Vaughan Mall License Agreement – Novocure Inc.

Dear Councilors,

The owner of the property located at 64 Vaughan Mall, Novocure Inc. requests a license of a portion of the Worth Lot & public alley that connects Hanover Street to the public parking lot as shown in the attached exhibit. The requested area includes the use of 10 parking spaces in the Worth Lot and public alley to provide safe work area for façade and roof installation, while maintaining a safe buffer for the general public. As a result of substantial design changes, delays in construction have caused this additional license request for the project.

Hampshire Development Corp. has been granted permission to act on behalf of Novocure for this license request.

Sincerely,

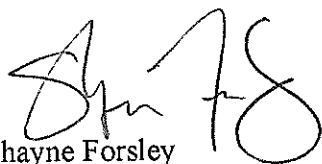

Shayne Forsley
General Manager

Cc: Novocure Inc.
Owner – 64 Vaughan Mall
195 Commerce Way
Portsmouth, NH 03801



February 15, 2022

195 Commerce Way
Portsmouth, NH 03801
United States

novocure.com

City of Portsmouth
1 Junkins Ave
Portsmouth, NH 03801

RE: Authorization for Shayne Forsley to act on behalf of 64 Vaughan Mall

To whom it may concern:

This letter serves as authorization for Shayne Forsley of Hampshire Development Corp. to represent and act on behalf of the project for 64 Vaughan Mall – Novocure Flagship Facility with respect to Novocure Inc.'s request for a license of a portion of the Worth Lot.

Sincerely,

A handwritten signature in blue ink, appearing to read "William P. Burke". The signature is fluid and cursive.

William P. Burke

Chief Human Resources Officer

Novocure Inc.
64 Vaughan Mall Owner

LICENSE AGREEMENT
64 VAUGHAN STREET

The City of Portsmouth (hereinafter "City"), a municipal corporation with a principal place of business of 1 Junkins Avenue, Portsmouth, New Hampshire 03801, for good and valuable consideration as set forth herein, hereby grants this Revocable License to Novocure Inc. (hereinafter "Owner") a corporation registered to do business in New Hampshire with a principal place of business at 195 Commerce Way, Portsmouth, NH 03801, through their agents, Hampshire Development Corp., a New Hampshire corporation located at 41 Industrial Drive, Exeter, New Hampshire 03833 ("Licensee") pursuant to the following terms and conditions:

1. **Areas of License and Use:** The Owner owns the land, with buildings and other improvements thereon, in the City of Portsmouth, Rockingham County, State of New Hampshire, located at 64 Vaughan Street, shown on the City of Portsmouth's Assessor's Map as Tax Map 0126-0001-0000 ("Subject Property"). For the Owner's title to the Subject Property, see Rockingham County Registry of Deeds at Book 6370 Page 1168.

License Area: The City authorizes Licensee to temporarily use ten (10) parking spaces in the Worth Lot that abut the Subject Property more particularly described in the attached Exhibit A.

2. **Use:** Licensee shall make use of the License Area for the purpose of installing exterior framing, façade and roofing and creating a barrier for public safety during construction at the Subject Property.
3. **Term:**

The license for the 10 parking spaces abutting Subject Property shall be for 82 consecutive days beginning January 10, 2023 and ending April 1, 2023.

Licensee may terminate this License prior to the end of the term by returning the License Areas to safe and effective use by the public prior to the expiration of the term of this License. The Licensee shall contact the Director of Public Works for a determination that the License Areas have

been temporarily returned to safe and effective use. Failure to remove all vehicles, barriers, materials and equipment and to return the License Areas to the City in the manner prescribed under this License at the end of the term may result in enforcement action by the City.

4. **Notice and Pilot:** Licensee shall provide notice to the City’s Director of Public Works when Licensee assumes control and use of the License Areas and again when it returns the License Areas to the City’s control and use.

During the term of this License Agreement, Owner will create a pilot of the proposed parking lot reconfiguration and improvements to the Worth Lot pursuant to a separate Development Agreement approved by the City Council on November 15, 2021. The pilot will be reviewed and approved by the Director of Public Works prior to the construction of the final improvements.

5. **License Fees:** The Licensee shall pay to the City a license fees in accordance with City Council Policy No. 2018-02 entitled “License Fee for Encumbrance of City Property”. The License Fee Policy provides that the Owner will be charged a daily fee of \$35 per day per encumbered parking space.

The License Area includes ten (10) parking spaces in the Worth Lot that abut the Subject Property. The fee of \$35 per parking space per day x 10 parking spaces = \$350 per day x 88 days is **\$28,700**.

The total License Fee shall be paid in full to the City in advance of the commencement of the term of this Agreement.

Because it is in the City’s interest that the Licensed Areas be returned to the public use as soon as possible, if the License Areas are returned to the City prior to the end of the License Term, the City will refund the Owner the portion of the License Fee paid but not used by the Licensee.

6. **Indemnification:** Licensee agrees to indemnify and hold harmless the City of Portsmouth for any and all property damage, bodily injury or personal injury which arises as a result of its utilization of the Licensed Areas. This obligation survives termination or revocation of this Agreement.
7. **Insurance:** At all times the Licensee shall maintain insurance for bodily injury and property damage in the amount of at least \$1,000,000 per occurrence. Licensee will provide proof of insurance to the City during the

term of this Agreement and the City will be named as an additional insured.

8. **Maintenance of Area:** During the term of this Agreement, Licensee shall maintain the License Areas in a safe, neat and orderly fashion and shall take such actions as are necessary to protect the public safety. The Licensee shall secure the perimeter of the License Areas and take such other measures as may be necessary for pedestrian and vehicular safety during use of the Licensed Areas.
9. **Damage:** Licensee agrees to remedy any damage to the License Areas caused by the Licensee's activities. The work will be performed by Licensee to City specifications and survive the terms of this License Agreement. The City may elect to accept reasonable reimbursement from the Licensee in lieu of remedy.
10. **Compliance with Other Laws:** This Agreement does not relieve Licensee from compliance with any other local, state or federal laws or regulations or conditions imposed by any local board. Failure to abide by any local, state or federal laws or regulations or any condition of site plan may, at the City's discretion, result in revocation.
11. **Revocation:** The City may terminate this Agreement or any provision contained in this Agreement on 72 hours written notice if Licensee fails to meet the terms and conditions of this License or if the public interest requires such termination. No 72 hour written notification is required by the City if it is an emergency.
12. **Contractor and Subcontractor Parking:** Licensee understands and agrees that its contractors and subcontractors for the project shall not use on-street parking. Language will be inserted in Licensee's vendors and suppliers Purchase Orders and Trade Subcontracts that make the prohibition against parking on City streets mandatory. Contractor shall limit/ manage construction vehicles and deliveries to avoid disruption to businesses, particularly during the holiday season. Contractor may use loading zones for active loading and unloading of materials, equipment and tools.

Dated this _____ day of _____, 2023

City of Portsmouth

By: _____

Karen Conard
City Manager

Pursuant to vote of the City Council
of

Dated this _____ day of _____, 2023.

Novocure Inc.

By: _____
Duly authorized

Dated this _____ day of _____, 2023.

Hampshire Development, Corp.

By: _____
Duly authorized

h/jferrini/license3/64Vaughan

Return To:
Legal Department
City Hall
1 Junkins Ave.
Portsmouth, NH 03801

SEWER EASEMENT DEED

GRANTOR, the **CITY OF PORTSMOUTH**, a municipal body politic, having a mailing address of 1 Junkins Avenue, Portsmouth, New Hampshire 03801, hereinafter "Grantor," for consideration paid, grants to **HOPE FOR TOMORROW FOUNDATION**, a New Hampshire non-profit corporation, 315 Banfield Road, Portsmouth, New Hampshire, "Grantee", with QUITCLAIM COVENANTS, the following easement with respect to Grantor's real property situate on Campus Drive in the City of Portsmouth, State of New Hampshire, City Tax Map 266. Lot 4:

1. **Permanent Easement Area**: A permanent easement for the purpose of a sewage pipe over the land of GRANTOR as shown on a plan entitled "As-Built Site – Sewer Plan, Tax Map 266, Lot 5, Saint Patrick Academy, 315 Banfield Road, Portsmouth, Rockingham County, N.H. prepared for North & South Construction Services", dated September 6, 2018, by SGC Engineering, LLC (hereinafter "the Plan"). The Plan to be recorded herewith.

A certain twenty foot wide sewer easement centered on an 8 inch gravity sewer bounded and described as follows:

Beginning at a point on a stone wall on the common property line of Grantor and Grantee, said point being South 57° 20' 54" East 22 +/- feet from a found iron rod on said stone wall at the most easterly corner of land now or formerly of Virginia Copeland (Tax Map 266, Lot 7), along land of Grantor (Tax Map 266, Lot 4) and land of Grantee (Tax Map 266, Lot 5).

Thence through land of said Grantor along the centerline of a pipeline, in a generally northwesterly direction parallel to the boundary of the property of Copeland, approximately 320 +/- feet; thence turning and running in a generally southeasterly direction, approximately 150 feet to an existing Sanitary Pump

Station on Grantor's parcel and identified as a wet well on the above-referenced plan.

2. **Purpose and Rights:** The Grantee shall have a permanent and non-exclusive easement and right of way in, under, across and over the Permanent Easement Area for the purpose of installing, maintaining, inspecting, removing, repairing, and replacing a sewer line with its associated pipes, manholes, and appurtenances.
3. **Notice and Coordination.** The Grantee shall have the right to remove obstructions including pavement, curbing, trees, bushes, undergrowth and other obstructions interfering with the activities authorized herein and to take such other actions as may be necessary, useful or convenient for the enjoyment of the easement rights herein granted with notice to and approval of Grantor (such approval not to be unreasonably withheld). The Grantee agrees to preserve access to any driveways and parking areas to the extent reasonably practicable.
4. **Grantee's Responsibility to Restore:** Disturbed areas within the Permanent Easement Area shall be back-filled and restored at the Grantee's expense. Paving and curbing and similar materials shall also be restored at the Grantee's expense.
5. **Grantor's Retained Rights:** Grantor retains the right to freely use and enjoy its interest in the Permanent Easement Area insofar as the exercise thereof does not endanger or interfere with the purpose of this instrument. Grantor further retains the right to require the relocation, in whole or in part, of the Grantee's sewer infrastructure at Grantee's cost if the public interest requires it. In such instance, Grantor shall provide a minimum of one-year's notice of the need to relocate the sewer line, in whole or in part, and Grantor shall cooperate in identifying or securing an alternative location for the sewer service on Grantor's property.
6. **Personal Property.** It is agreed that the pipes, manholes, and appurtenances connecting to the Sanitary Pump Station within the easement area, whether fixed to the realty or not, shall be and remain the property of the Grantee. Pipes, manholes and appurtenances related to any drain lines are the responsibility of the Grantor. The sanitary pump station is the property of the Grantor. Grantor shall be responsible for the routine inspection and maintenance of the pump station, but the costs of any material capital investment or improvement shall be shared equally between Grantor and Grantee and the two shall consult in good faith with regard to such work.
7. **Easement to Run with Land:** All rights and privileges, obligations and liabilities created by this instrument shall inure to the benefit of, and be binding upon, the heirs, devisees, administrators, executor, successors and assignees of the Grantee and of the Grantor, the parties hereto and all subsequent owners of the Premises and shall run with the land.

MEANING AND INTENDING to convey an easement over a portion of the premises conveyed to the within Grantor by deed of Hope for Tomorrow Foundation dated March 14, 2022 and recorded in Book 6390, Page 2501 of the Rockingham County Registry of Deeds.

This is an exempt transfer per RSA 78-B:2(I).

DATED this _____ day of _____, 2023.

The City of Portsmouth

By: _____

Name: Karen Conard, City Manager

STATE OF NEW HAMPSHIRE

COUNTY OF _____

The foregoing instrument was acknowledged before me this _____ day of _____, 2023.

Justice of the Peace/Notary Public

Printed Name:

My Commission Expires:

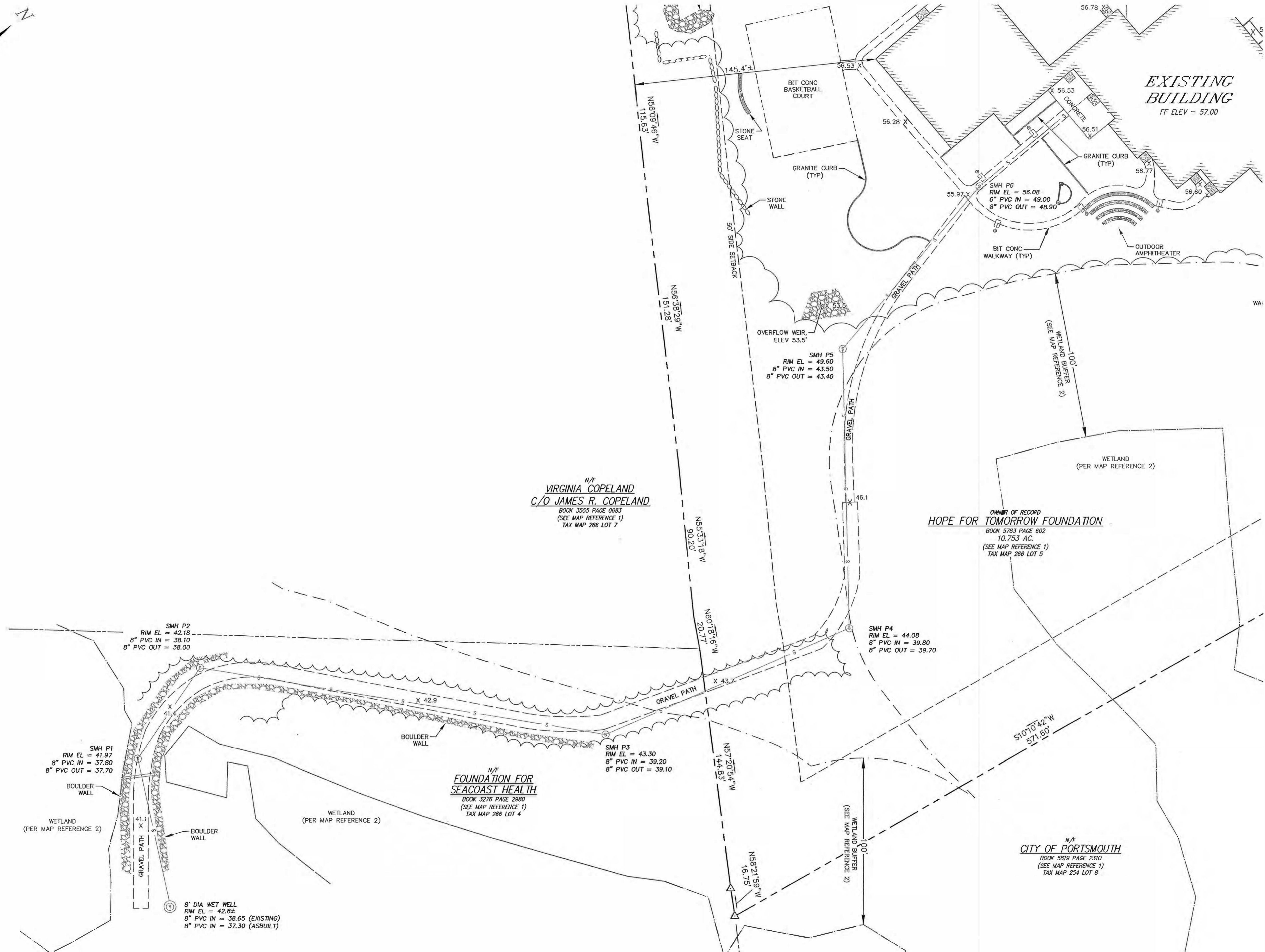
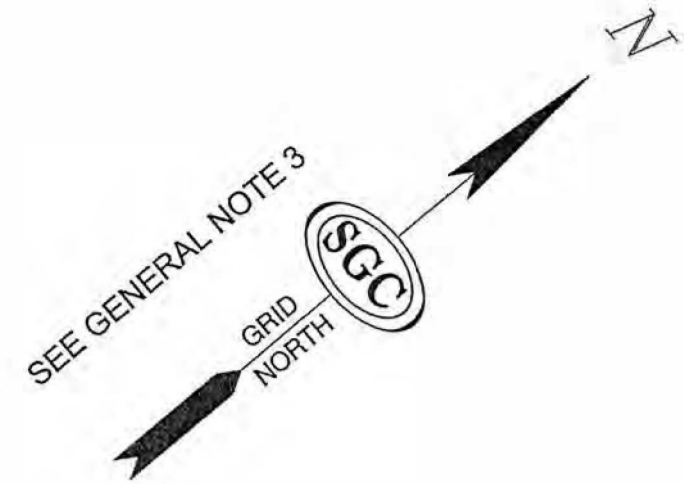

N/F
VIRGINIA COPELAND
C/O JAMES R. COPELAND
 BOOK 3555 PAGE 0083
 (SEE MAP REFERENCE 1)
 TAX MAP 266 LOT 7

OWNER OF RECORD
HOPE FOR TOMORROW FOUNDATION
 BOOK 5783 PAGE 602
 10.753 AC.
 (SEE MAP REFERENCE 1)
 TAX MAP 266 LOT 5

N/F
FOUNDATION FOR SEACOAST HEALTH
 BOOK 3276 PAGE 2980
 (SEE MAP REFERENCE 1)
 TAX MAP 266 LOT 4

N/F
CITY OF PORTSMOUTH
 BOOK 5819 PAGE 2310
 (SEE MAP REFERENCE 1)
 TAX MAP 254 LOT 8

NO.	DATE	APPROVED FOR REVIEW
1	09/06/2018	

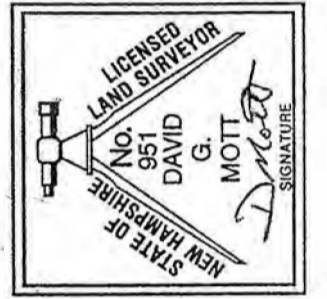

SGC ENGINEERING, LLC
 • Civil Design & Survey Engineering
 • Environmental & Regulatory Permitting
 • Electrical Power Systems Engineering



SERVING OUR CLIENTS IN THE U.S.A. & CANADA
 49 Harbor Street, Suite 2
 Westbrook, Maine 04092
 Tel: 207-270-6990
 Fax: 207-270-3100
 24 North Street, Suite 5
 Portland, Maine 04101
 Tel: 207-540-1412
 Fax: 207-540-1412

PROJECT: 148001
 DWS: 148001_AS-BUILT
 SHEET 3 OF 3

AS-BUILT SITE - SEWER PLAN
 TAX MAP 266 LOT 5
SAINT PATRICK ACADEMY
315 BANFIELD ROAD, PORTSMOUTH,
ROCKINGHAM COUNTY, N.H.
 PREPARED FOR:
NORTH & SOUTH CONSTRUCTION SERVICES
 55 CALEF HIGHWAY, SUITE 2, BARRINGTON, N.H. 03825

SEE SHEET AB-1 OF 3 FOR GENERAL NOTES, MAP REFERENCES AND LEGEND.

Return to: ^(m)
 City of Portsmouth
 2 Junkins Avenue
 Portsmouth NH 03801

Book: 6083 Page: 614

20006225 02/11/2020 11:49:28 AM
 Book 6083 Page 614 Page 1 of 2
 Register of Deeds, Rockingham County



RECORDING	14.00
SURCHARGE	2.00



ACCESS EASEMENT FOR WATER SERVICES

KNOW ALL PERSONS BY THESE PRESENTS, that **HOPE FOR TOMORROW FOUNDATION** with an address of 1950 Lafayette Road, Portsmouth, New Hampshire, for consideration received, grants to the **CITY OF PORTSMOUTH**, a municipal body politic having a mailing address of 1 Junkins Avenue, Portsmouth, County of Rockingham and State of New Hampshire 03801, with **QUITCLAIM COVENANTS** an easement over, below, along, and across the premises described herein, located at 315 Banfield Road, Portsmouth, County of Rockingham, State of New Hampshire, (Tax Assessor's Map No. 266, Lot 5), and being more particularly described as follows:

A certain tract or parcel of land with the buildings therein situated on the southerly side of Banfield Road in Portsmouth, County of Rockingham, State of New Hampshire and shown as Proposed Parcel 266-5 on a plan titled Lot Line Revision Plan, Campus Drive, Banfield & Peverly Hill Roads, Portsmouth, New Hampshire recorded as sheet 2 of 4 recorded in the Rockingham County Registry of deeds as plan D-39897.

Meaning and intending to convey an easement over the premises conveyed to the within grantor by Deed of the Foundation for Seacoast Health, dated December 16, 2016 and recorded in the Rockingham County Registry of Deeds at Book 5783, Page 0602.

Purpose and Rights: The Grantee shall have a perpetual, permanent uninterrupted and unobstructed nonexclusive easement for the purpose of enabling the City of Portsmouth to access private water infrastructure including mains, water shutoffs, and valves for the limited purpose of leak detection and similar infrastructure inspection services and for access to valves for purposes of turning on and shutting off municipal water service. Grantee shall have no responsibility for installation, maintenance, operation, or replacement of the water infrastructure.

Retained Rights: Grantor retains the right to freely use and enjoy its interest in the easement area insofar as the exercise thereof does not interfere with the purpose of this instrument.

Easement To Run With Land: All rights and privileges, obligations and liabilities created by this instrument shall inure to the benefit of, and be binding upon, the heirs, devisees, administrators, executor, successors and assignees of the Grantee and of the Grantor, the parties hereto and all subsequent owners of the Premises and shall run with the land.

This is an exempt transfer per R.S.A. 78-B:2(I).

IN WITNESS WHEREOF, the parties have executed this document on the ___ day of December 2019.

**HOPE FOR TOMORROW
FOUNDATION**

Witness: 

By: 
James Broom, President

STATE OF NEW
HAMPSHIRE
COUNTY OF ROCKINGHAM

Personally appeared the above-named James Broom, in his capacity of President of Hope for Tomorrow Foundation and acknowledged the foregoing instrument to be his free act and deed executed for the purposes contained therein.





Notary Public/Justice of the Peace
My commission expires: Oct 02, 2024

Damalis Medrano
Notary Public, State of New Hampshire
My Commission Expires Oct. 02, 2024

December 30th, 2022

The Honorable Deaglan McEachern, Mayor of Portsmouth
and members of the Portsmouth City Council.
1 Junkins Ave
Portsmouth NH, 03810

Dear Mayor McEachern and the Members of the City Council,
On behalf on the Alzheimer's Association, I would like to submit for the Agenda, a proposed date for the 2023 Annual Seacoast Walk to End Alzheimer's. This year we would like to hold the event on Sunday October 1st, 2023 and hope to start and end at the Little Harbour School as usual. I have attached our normal route options for Walkers that we typically use each year. We understand the stress that such events can have on the surrounding community and assure you that The Alzheimer's Association is cognizant of your concerns, and is committed to upholding the standards of years past.

We offer three route options for participants. Attached, please find the three route options drawn out for your review. We are planning to use the same routes as last year, but are flexible pending any construction changes or issues that may arise. We will plan on engaging the help of the Portsmouth Police, as in 2022 we hired a police detail to be both on-site and also at any busy intersections to assist in route crossing. The Walk will take place on the sidewalks through the city to minimize the impact on traffic. We understand what it means to be a good neighbor in the community and will be mindful of the residents of the City of Portsmouth as we raise awareness and funds for a critical cause.

We would expect approximately 1,000 participants at this event, our premier fundraising and awareness event for the Alzheimer's Association in the Seacoast Area. Additionally, we will have approximately 60 combined volunteer and staff on site.

The Walk site opens up at 8:30am for registration, the Walk itself kicks off at 10 and we are cleaned up and off the premises by 1pm.

We look forward to working with you, please reach out with any questions.

Sincerely,
Maria Stephanou
NH Walk Manager - Alzheimer's Association
mmstephanou@alz.org

508-887-5025

.5 Mile Route



.5 Mile

1.2 Mile Route

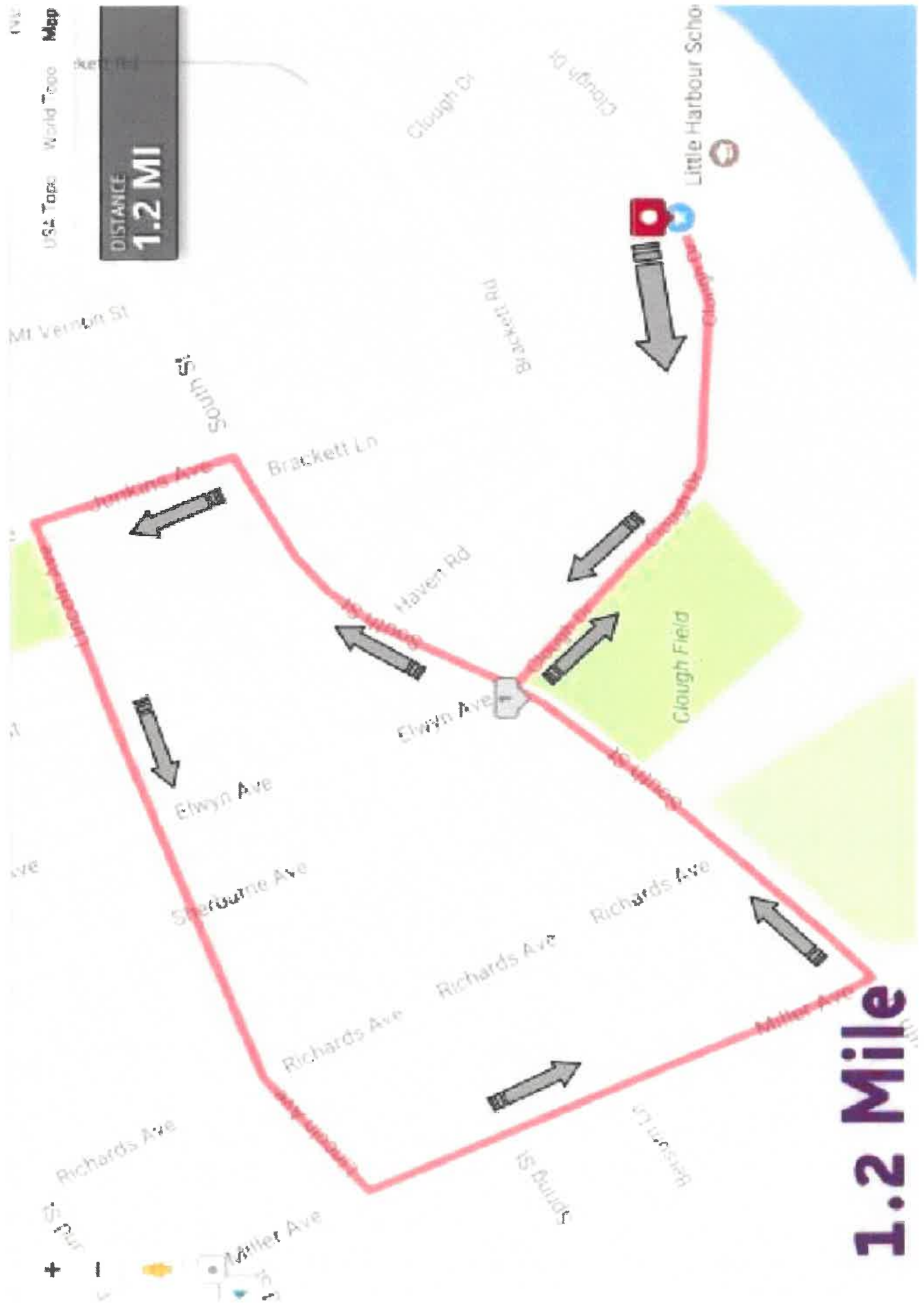

1.2 Mile

Stay on walkway thru Veterans Memorial park

Water Station
Islington/Summer

Start/End
Little Harbour School
50 Clough Dr.
Portsmouth

3.2 Mile



Friends of the South End
PO Box 443
Portsmouth, NH 03802



December 14, 2022

Mayor & City Council
Portsmouth City Hall
One Junkins Avenue
Portsmouth, NH 03801

Dear Mayor & City Council,

On behalf of the Friends of the South End and the annual Fairy House Tour event, I am seeking the City's permission to host this event on Saturday, September 23, 2023 and Sunday, September 24, 2023 from 10 a.m.- 3 p.m. both days, as well as to help clear the area from conflicting events.

As in years past, the Tour will take place on the grounds of the Governor John Langdon House, Strawberry Banke Museum, The Players' Ring and in collaboration with the Prescott Park Arts Festival. We are asking the City of Portsmouth for permission to use Pierce Island for parking as well as the use of Prescott Park. We would again like to close Washington Street between Hancock and Court Streets to through traffic from 9:30 a.m.- 4 p.m. both days.

In addition, we anticipate hiring two police officers to aid in the public's crossing over Marcy Street at the Prescott Park flagpole and at the intersection of Mechanic Street. For the safety of event participants, we request that no races (bike or running) be scheduled on abutting streets during our event.

We look forward to working with the city staff to bring one of our area's most beloved community events to life in Portsmouth. Please let me know if you need additional detailed information at this time so that this request can be added to the next Town Council meeting agenda for timely scheduling and approval.

Thank you for helping us to again create a magical event in the South End for the benefit of our children and community.



Debra C. Smith
2022 Event Manager
info@fairyhousetour.com
860/836-7370 cell
603/292-5862 home

Cc: Mary Thomas, FOSE Co-President
Jessica Griffin, Town Manager Office

Hi Jessica –

I hope all is well. I am reaching out on behalf of the Margarita Half Marathon & 5K. I believe you worked with my co-worker Paul Rodriguez on the 2022 event. I am reaching out to once again seek approval to conduct the **2023 Margarita Half Marathon & 5K on Sunday, April 30th, 2023** through the City of Portsmouth. The event will be conducted with Mercedes-Benz of Portsmouth and will support a TBD charitable organization. The race is planning to move back to its original **8:00 AM start time** in 2023.

The course spends only about two tenths of a mile in Portsmouth when runners travel north on Portsmouth Avenue from the Greenland side to Route 33 and then goes right onto Greenland Road back into the Town of Greenland. Just like year's past, there will be a cone lane along the 2/10ths of a mile on Route 33. We will again hire a State Police detail for the Route 33 detail.

Event Info

Event Date: Sunday, April 30th, 2023

Start Time: 8:00 AM

Runners will be on the Portsmouth Road for 10 minutes or less.

Runners on Route 33 will be in a coned lane.

A State Police Officer will be hired for the intersection of Portsmouth Ave & Greenland Road.

Insurance:

An insurance certificate, naming the City of Portsmouth as an additional insured will be emailed to you from our insurer prior to the event.

Attached you will find the New Hampshire DOT Parade Permit for signature and the Half Marathon & 5K race maps.

Please let me know if you need any additional information from me or have any questions. I look forward to working with you on this event.

Best,

|



Evan Dolecki
Event Operations Manager, New England

Ventures Endurance

edolecki@venturesendurance.com | [860-921-](tel:860-921-6945)

[6945](tel:860-921-6945) | VenturesEndurance.com



USA TODAY NETWORK

2023 MARGARITA HALF MARATHON COURSE



START: Lowes Lot Loop
Exit: Rear Lowes Lot
Right: Portsmouth Ave
Right: Greenland Rd
Right: Portsmouth Ave
Left: Newington Rd
Right: Newington Rd
Continue: McIntyre Rd
Right: Little Bay
Right: Nimble Hill
Loop: Around DPW lot
Back: Nimble Hill Rd
Left: Little Bay
Left: McIntyre
Continue: Newington Rd
Right: Portsmouth Ave
FINISH: Mercedes Benz of Portsmouth

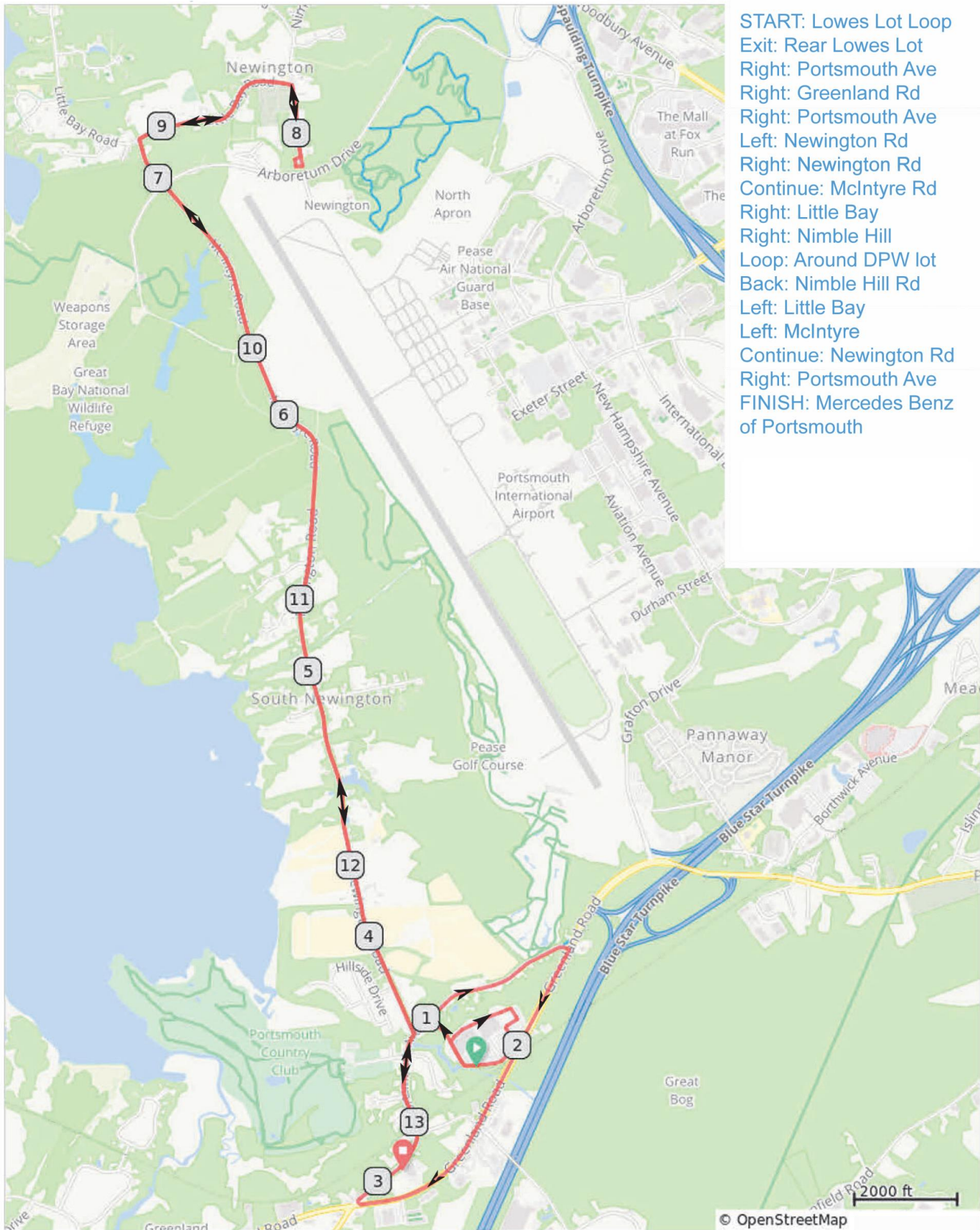

2023 MARGARITA 5K COURSE MAP



START: Lowe's Lot Loop
Exit: Rear Lowe's Lot
Right: Portsmouth Ave
Right: Greenland Ave
Right: Portsmouth Ave
FINISH: Mercedes Benz of
Portsmouth

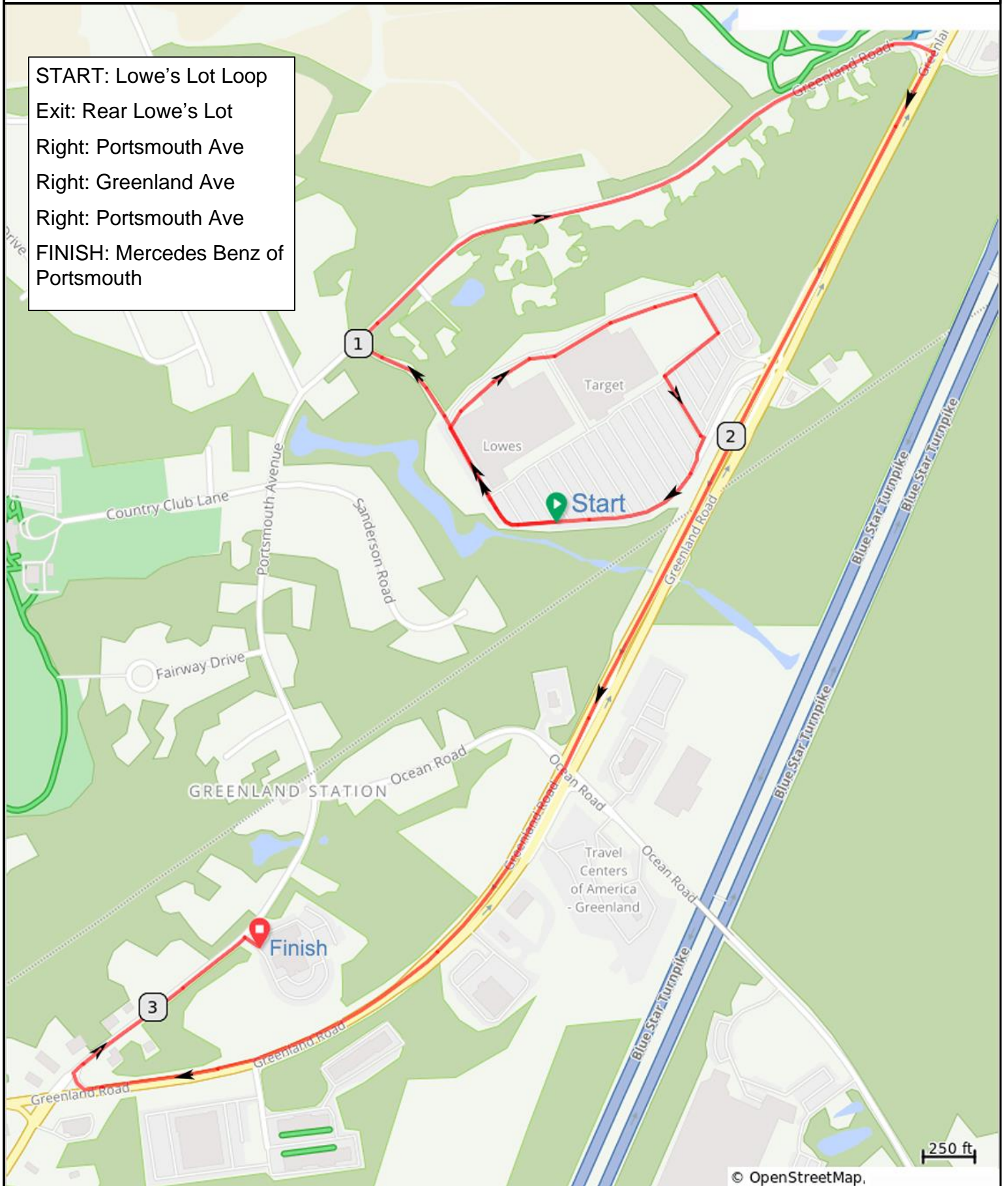

250 ft

STATE OF NEW HAMPSHIRE
Application for Parade Permit or Other
Activity Conducted on State Highway System

Today's Date 12/16/2022

To: Department of Transportation
Transportation Management Center
PO Box 483, 110 Smokey Bear Blvd
Concord, New Hampshire 03302-0483
Phone (603) 271-6862
Fax (603) 271-8626

Under provisions of RSA 286:2 and RSA 236:1, application is made for a parade / activity on the state highway system.

Indicative data is shown below:

Type of activity?

Road Race - Runners and Walkers

If so, what type (foot, bike, etc.)?

Foot

Will event effect highway safety?

No

Will highway traffic be delayed?

Yes

If so, how long?

Less than 10 minutes

Will highway traffic be detoured?

No

Name of sponsoring organization:

Loco Races, LLC

Mail permit to:

Evan Dolecki

1 Maple Ave., Unit C

Collinsville, CT 06019

860-921-6945

Phone no. where I may be reached:

Promote a fit lifestyle and charity

Purpose of activity:

Town of Portsmouth

Name of Municipality:

Sunday, April 30th, 2023

Date of activity:

8:00 AM - 8:45 AM

Starting and ending times:

Route 33 Portsmouth Avenue

State route(s) to be traveled:

State Police

Traffic control provided by:

Approved by Town Officials

Selectmen / Town Manager / Police Chief
(circle one)

Signed by Evan Dolecki
(Applicant)

Please attach a simple map or sketch plotting the **start, finish, route(s) of travel, detour(s), and parking area(s)** if provided.

Recommended:

District Engineer

Pedestrians' Rights and Duties

265:34 Pedestrians Subject to Traffic Signs and Regulations. A pedestrian shall obey the instructions of any traffic sign or regulation specifically applicable to him, unless otherwise directed by a police officer. Pedestrians shall be subject to traffic and pedestrian control signals as provided in RSA 265:9 unless required by local ordinance to comply strictly with such signals. At all other places, pedestrians shall be accorded the privileges and shall be subject to the restriction stated in this chapter.

265:35 Pedestrian's Right of Way in Crosswalks.

I. When traffic control signals are not in place or not in operation the driver of a vehicle shall yield the right of way, slowing down or stopping if need be to so yield, to a pedestrian crossing the roadway within a crosswalk when the pedestrian is upon the half of the roadway upon which the vehicle is traveling, or when the pedestrian is approaching so closely from the opposite half of the roadway as to be in danger.

II. No pedestrian shall suddenly leave a curb or other place of safety and walk or run into the path of a vehicle which is so close as to constitute an immediate hazard.

III. Paragraph I shall not apply under the conditions stated in RSA 265:36.

IV. Whenever any vehicle is stopped at a marked crosswalk or at any unmarked crosswalk at an intersection to permit a pedestrian to cross the roadway, the driver of any other vehicle approaching from the rear shall not overtake and pass such stopped vehicle.

265:36 Crossing at Other Than Crosswalks.

I. Every pedestrian crossing a roadway at any point other than within a marked crosswalk or within an unmarked crosswalk at an intersection shall yield the right of way to all vehicles upon the roadway.

II. Any pedestrian crossing a roadway at a point where a pedestrian tunnel or overhead pedestrian crossing has been provided shall yield the right of way to all vehicles upon the roadway.

III. Between adjacent intersections at which traffic control signals are in operation pedestrians shall not cross at any place except in a marked crosswalk.

IV. No pedestrian shall cross a roadway intersection diagonally unless authorized by traffic control devices; and, when authorized to cross diagonally, pedestrians shall cross only in accordance with the official traffic control devices pertaining to such crossing movements.

265:37 Drivers to Exercise Due Care. Notwithstanding the foregoing provisions of this chapter or the provisions of any local ordinance, every driver of a vehicle shall exercise due care to avoid colliding with any pedestrian or any person propelling a human-powered vehicle and shall give an audible signal when necessary and shall exercise proper precaution upon observing any child or any obviously confused, incapacitated or intoxicated person.

265:38 Pedestrians to Use Right Half of Crosswalks. Pedestrians shall move, whenever practicable upon the right half of crosswalks.

265:39 Pedestrians on Roadway.

I. Where sidewalks are provided it shall be unlawful for any pedestrian to walk along and upon an adjacent roadway.

II. Where a sidewalk is not available, any pedestrian walking along and upon a way shall walk only on a shoulder, as far as practicable from the edge of the roadway. Where neither a sidewalk nor a shoulder is available, any pedestrian walking along and upon a way shall walk as near as practicable to an outside edge of the roadway, and if on a two-way roadway, shall walk only on the left side of the roadway.

III. Except as otherwise provided in this chapter, any pedestrian upon a roadway shall yield the right of way to all vehicles upon the roadway.

265:40 Pedestrians Soliciting Rides or Business.

I. No person shall stand on the traveled portion of a roadway for the purpose of soliciting a ride, employment, business or contributions from the occupant of any vehicle.

II. No person shall stand on or in proximity to the traveled portion of a street or way for the purpose of soliciting the watching or guarding of any vehicle while parked or about to be parked on a street or way.

III. It shall be lawful for any person to hitchhike or solicit a ride from the occupant of any vehicle upon any road or way, or limited access road and highway provided that the individual is not, when so doing, standing on the paved portion of the road or way.

IV. No person shall signal a moving vehicle or stop a vehicle on any public way in order to solicit or sell a ticket of admission to an entertainment or sports event.

M E M O R A N D U M

TO: Karen Conard, City Manager

FROM: Peter Britz, Planning Director 

DATE: January 3, 2023

RE: City Council Referral – Projecting Sign
Address: 60 Penhallow Street
Business Name: Hearth Food Garden, LLC
Business Owner: Mark McNabb

Permission is being sought to install a projecting sign that extends over the public right of way, as follows:

Sign dimensions: 42" diameter
Sign area: 9.6 sq. ft.

The proposed sign complies with zoning requirements. If a license is granted by the City Council, no other municipal approvals are needed. Therefore, I recommend approval of a revocable municipal license, subject to the following conditions:

1. The license shall be approved by the Legal Department as to content and form;
2. Any removal or relocation of the sign, for any reason, shall be done at no cost to the City; and
3. Any disturbance of a sidewalk, street or other public infrastructure resulting from the installation, relocation or removal of the signs, for any reason, shall be restored at no cost to the City and shall be subject to review and acceptance by the Department of Public Works.

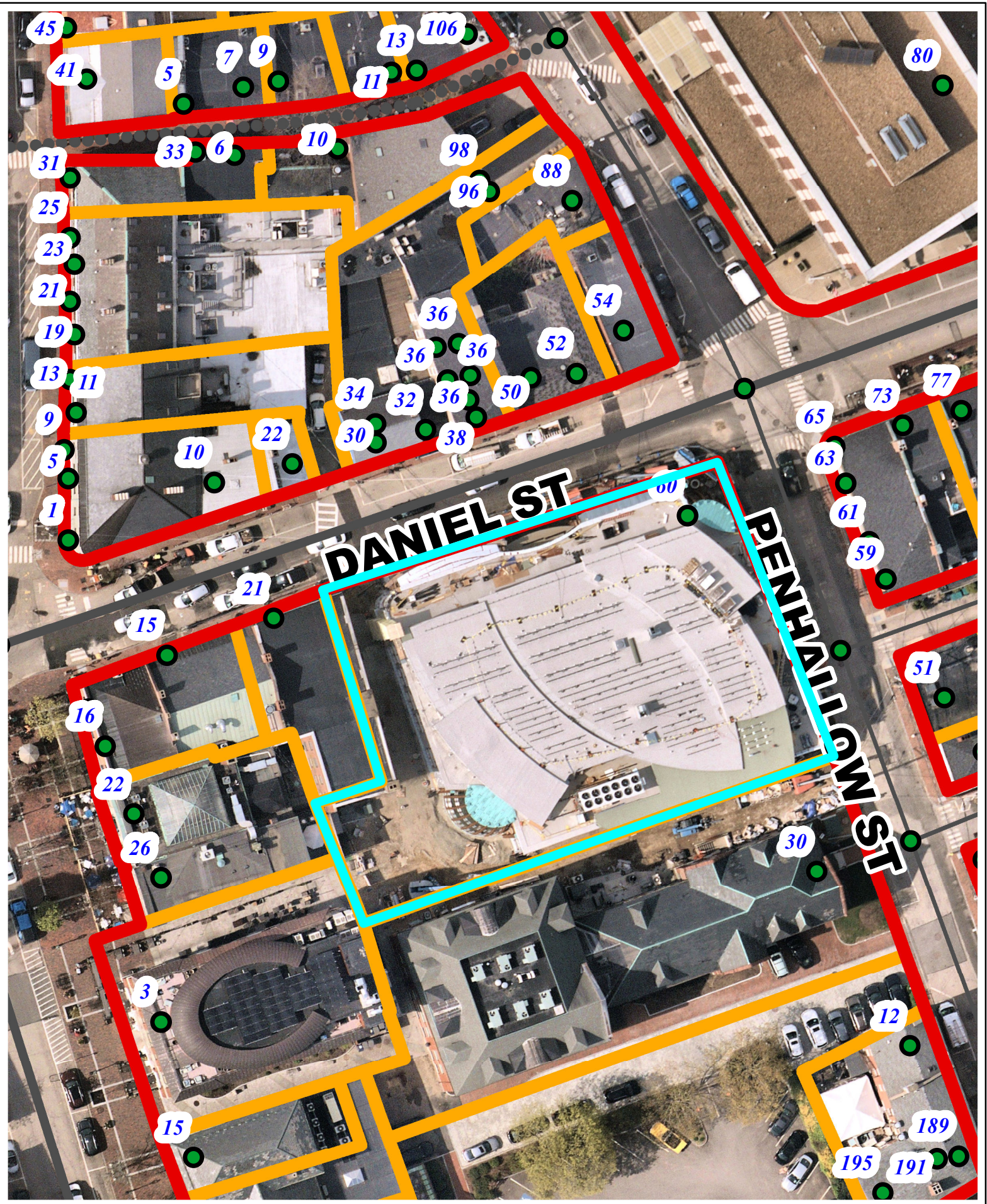

DANIEL ST

PENHALLOW ST

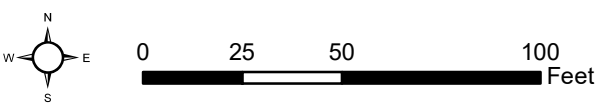

**Request for license
60 Penhallow Street**

PROOF for: Hearth Food Garden Hanging Sign

Company Hearth Food Garden
 Name Heidi Feinstein e-mail: heidi@hearthfoodgarden.com
 Phone _____
 Date 12/23/22
 Est. Due Date _____
 Saved as: hearth food garden.cdr

TIMBERLINE SIGNS

139 Lafayette Road Rye, NH 03870
 p.603-964-1575 f.603-964-1576
 www.timberlinesigns.com timberlinesigns@yahoo.com

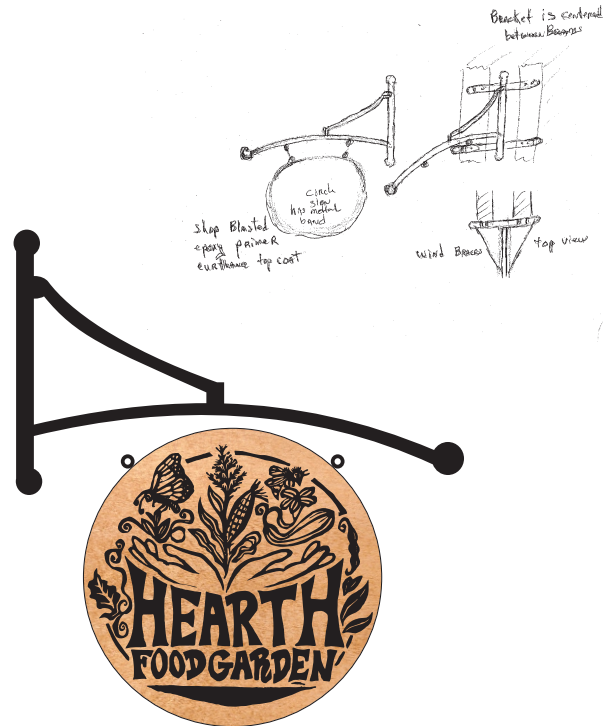

2 sided stained wood
 raised "Hearth Food Garden"
 everything else flat painted
 black steel band around edge
 eyelets welded to band
 curved scroll bracket

qty: 1 @ 42"

bottom of sign approx. 108" from sidewalk



I hereby authorize TIMBERLINE SIGNS to produce the above layout. 100% Payment will be expected upon completion of project unless other arrangements have been made prior. Customer has the option to purchase the artwork to be used as a logo or for other personal promotions for a determined fee. For pricing please inquire within. All designs and custom artwork remain the property of Timberline Signs until the order is complete and paid in full.

Please review, make necessary corrections, sign and fax or return to Timberline Signs, LLC. We will not begin production until this document is signed and returned. A 50% deposit is required to begin production on all jobs exceeding \$100.

Note: Designs are not actual size and Colors do not accurately represent finished product colors.

Signature: _____ **Date:** _____

Please Return signed Email to timberlinesigns@yahoo.com

December 22, 2022

Karen Conard, City Manager
City of Portsmouth
1 Junkins Avenue
Portsmouth, NH 03801

RE: City of Portsmouth Map 107 – Lot 27
60 Penhallow at Brick Market

Dear Ms. Conard,

On behalf of Dagny Taggart, LLC and Hearth Food Garden, please allow this letter to serve as authorization to submit the attached signage request to the City Council for the site formally known as 60 Penhallow Street, Portsmouth, NH – first floor footprint.

The package includes a projecting sign at the northwest corner of the building's main entry along Daniel and Penhallow Street(s) for the sole benefit of Hearth Food Garden wherein a projecting sign license is sought.

An additional sign along the secondary entry to Hearth Food Garden will be affixed to the building within the fountain public area. This sign includes a lighting component (conveying light through the cut-out letters), and this package includes the specifications from the sign vendor.

Thank you for your consideration.

Sincerely,

Hearth Food Garden, LLC



Mark A. McNabb
Manager/Owner



2 sided stained wood
 raised "Hearth Food Garden"
 everything else flat painted
 black steel band around edge
 eyelets welded to band
 curved scroll bracket

qty: 1 @ 42"

bottom of sign approx. 100" from sidewalk

page 4

Page 1

Peter Happing
 66 Rock St
 Portsmouth NH
 436 4859

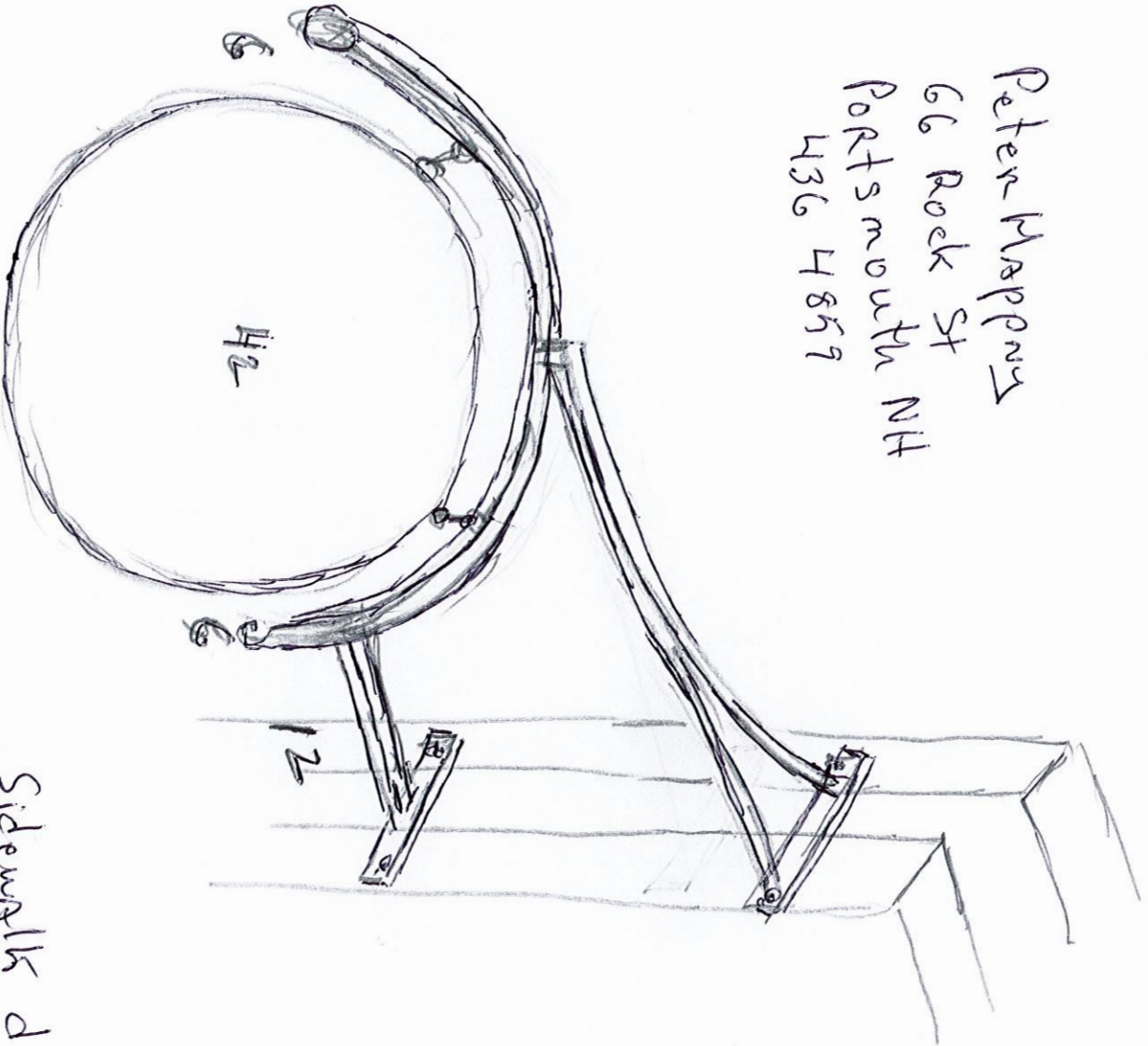

$$\frac{42}{24} = \frac{7}{4}$$

Sidewalk distance

106
 - 12 vehicle on sidewalk

94 Available

page 5

Longer From
 Buildings

6 to 8"

Daniel St

Bracket B

OVERVIEW OF CORNER AREA FROM AFAR
Sign Location - Hearth Food Garden
Corner of Daniel Street & Penhallow Street



STANGRAIM 3DS

M E M O R A N D U M

TO: Karen Conard, City Manager

FROM: Peter Britz, Planning Director 

DATE: January 3, 2023

RE: City Council Referral – Projecting Sign
Address: 60 Penhallow Street
Business Name: River Wharf Hospitality
Business Owner: Mark McNabb

Permission is being sought to install a projecting sign that extends over the public right of way, as follows:

Sign dimensions: 40" diameter
Sign area: 8.7 sq. ft.

The proposed sign complies with zoning requirements. If a license is granted by the City Council, no other municipal approvals are needed. Therefore, I recommend approval of a revocable municipal license, subject to the following conditions:

1. The license shall be approved by the Legal Department as to content and form;
2. Any removal or relocation of the sign, for any reason, shall be done at no cost to the City; and
3. Any disturbance of a sidewalk, street or other public infrastructure resulting from the installation, relocation or removal of the signs, for any reason, shall be restored at no cost to the City and shall be subject to review and acceptance by the Department of Public Works.

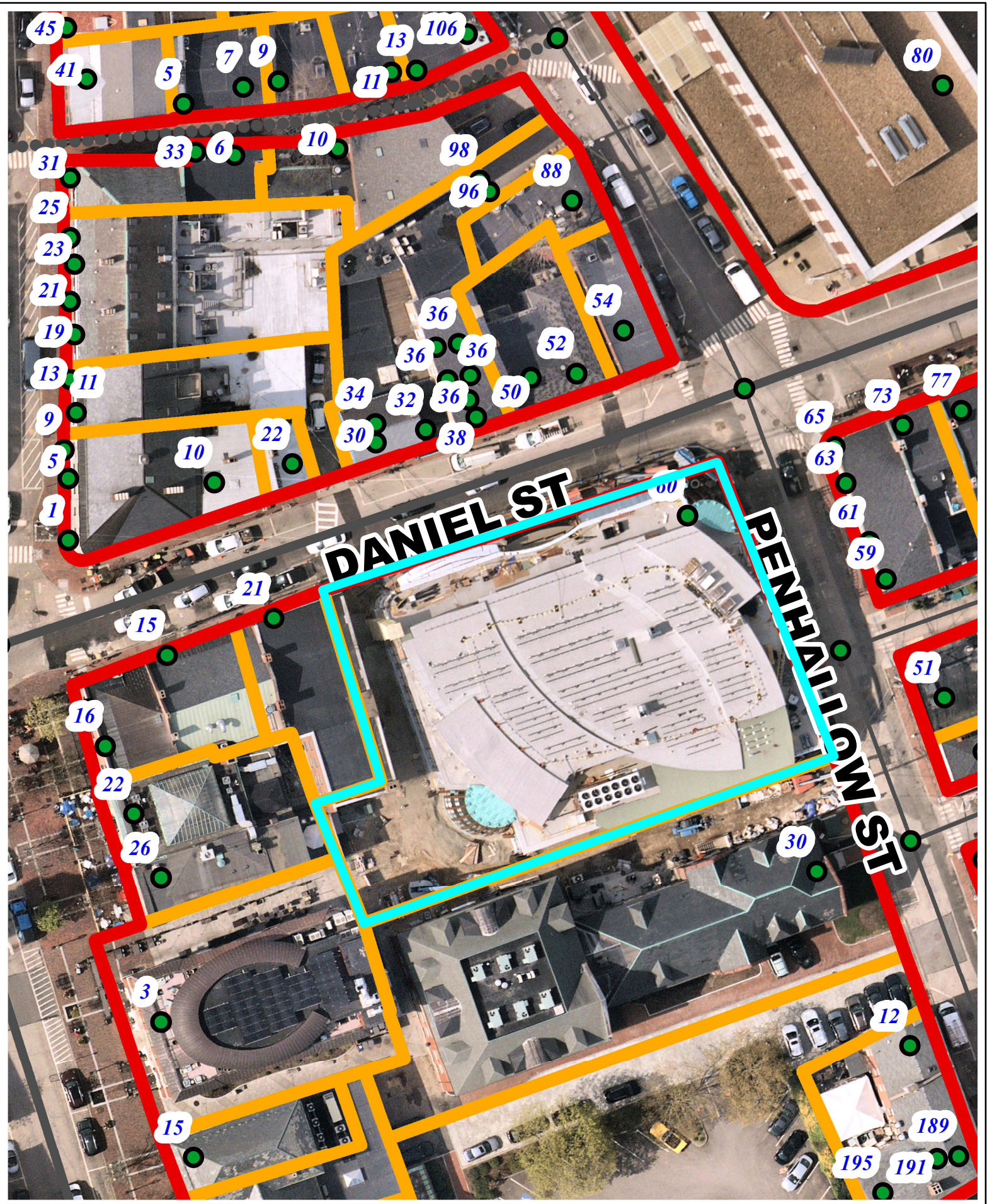

DANIEL ST

PENHALLOW ST

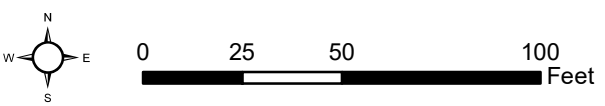

**Request for license
60 Penhallow Street**

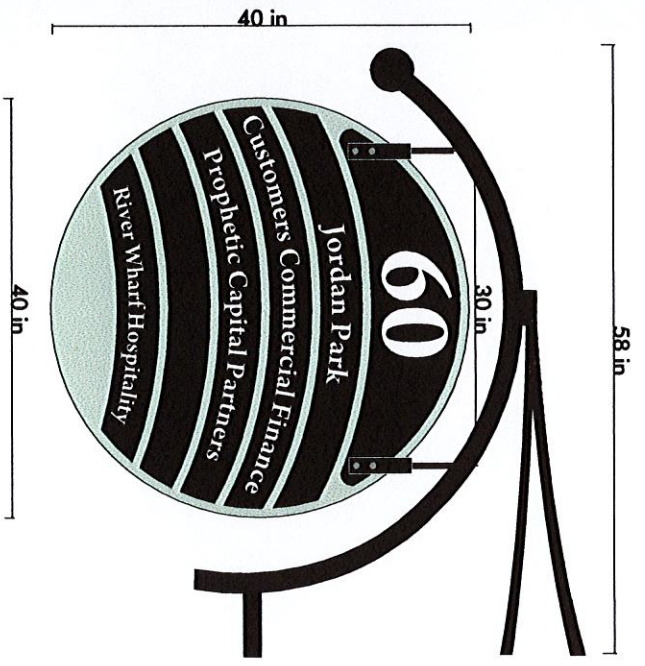
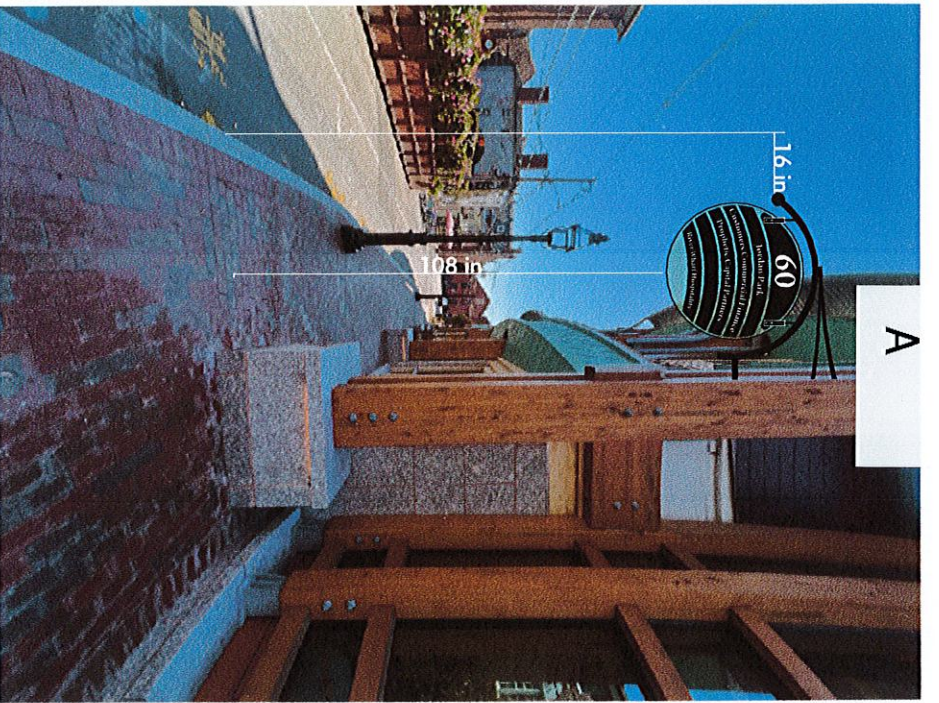

40" Circle Translucent Colored Acrylic Raised 1/4" Matte Dibond Panel with white vinyl text
 "60" raised 1/4" White acrylic
 Metal fabricated custom hooks - thru bolted
 Custom bracket made by others

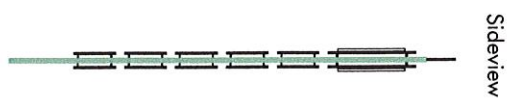

Sideview

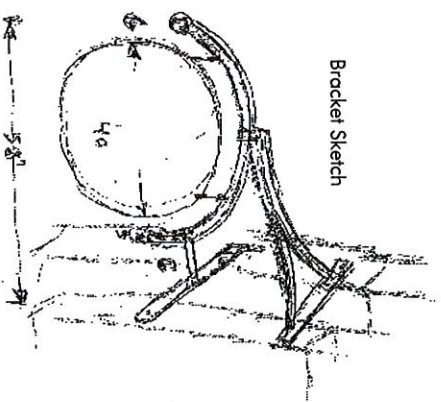

Bracket Sketch

 Portsmouthsign.com 603-436-0047	REVISION: All orders under \$250 include 1 revision only. All orders over \$250 include 2 revisions only. Additional revisions will be charged at \$25 per revision. PLEASE NOTE: Designs are NOT actual size and color may vary depending on printer and/or monitor.	12/8/2022 I understand this Order Form is the final production order and replaces all previous drawings, notes and verbal instructions to this job. Standard vinyl & paint colors will be used. Custom colors and specific matches to PMS colors will be an additional fee. I have carefully reviewed this form and verify that it contains all necessary specifications and represents my order. I authorize fabrication according to this approval. SIGNATURE: <i>Maurit Good</i>	RETURN SIGNED TO: service@portsmouthsign.com Date: 12.12.22
--	--	---	--

Shop Use Only: SS DS Materials: Background Color: Vinyl Color: HP Int Other:

Multi tenant sign - Submission 60 Penhallow Projecting Sign {please refer to Portsmouth Sign Co. rendering, as well as Peter Happy diagram for design of bracket, as attached}

Submitted by Marie J. Bodi, EVP McNabb Properties



please see below for approximate location

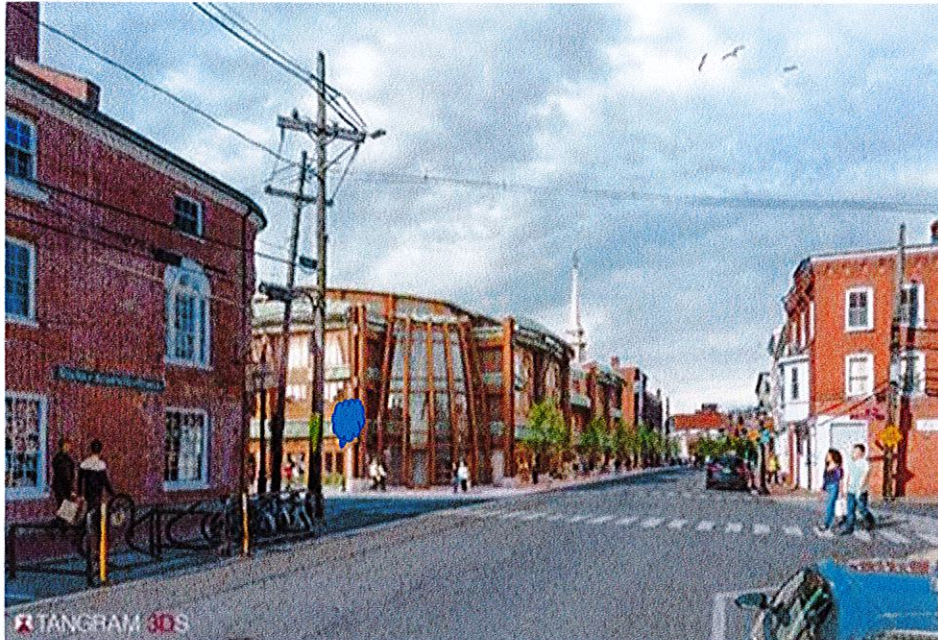

For the benefit of:

Jordan Park, Frank Ghali, President

Customers Commercial Finance, Samuel Smith, III, President

Prophetic Capital Partners, Paul J. McKeon, president

River Wharf Hospitality, Mark A. McNabb, Manager/Owner

For further information, please do not hesitate to contact me at marie@mcnabbgroup.com

Submitted 12/22/22

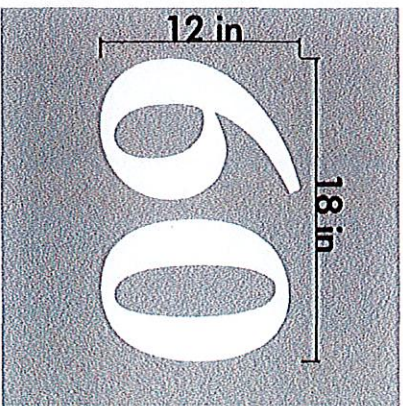

x1 White Decal



 PortsmouthSign.com
 603-436-0047

REVISION:
 All orders under \$250 include 1 revision only. All orders over \$250 include 2 revisions only. Additional revisions will be charged at \$25 per revision.

PLEASE NOTE:
 Designs are NOT actual size and color may vary depending on printer and/or monitor.

11/18/2022

I understand this Order Form is the final production order and replaces all previous drawings, notes and verbal instructions to this job. Standard vinyl & paint colors will be used. Custom colors and specific matches to PMS colors will be an additional fee. I have carefully reviewed this form and verify that it contains all necessary specifications and represents my order. I authorize fabrication according to this approval.

SIGNATURE: _____

RETURN SIGNED TO: service@portsmouthsign.com

Date: _____

©COPYRIGHT 2019, BY PORTSMOUTH SIGN COMPANY. All designs and custom artwork remain the property of Portsmouth Sign Company until the order is complete and paid in full.

Shop Use Only: Qty: SS DS Materials: _____ Background Color: _____ Vinyl Color: HP Int Other: _____

CITY COUNCIL E-MAILS

Received: December 8, 2022 (after 9:00 a.m.) – January 5, 2023 (before 9:00 a.m.)

January 09, 2022 Council Meeting

Submitted on Thu, 12/08/2022 - 10:30

Full Name

Drew Martin

Email

drew_03223@yahoo.com

Subject

Pilot Parking Program

Address

230 McDonough St

Message

Hello All,
I'm sure you've all already discussed this but I'd like to add my two cents on the Parking Pilot in the Islington Creek Neighborhood. I think that when we are trying to come up with a parking permit plan it should be based on proximity to downtown, not by neighborhood. I live between Salem and Dover at the far West end of McDonough St and there has never been a parking issue here, before or during the pilot program. The pilot parking program made it so that friends and family had to move their cars every two hours even though there were always double digit parking spaces open on my block of McDonough. Or they could park all day in a spot on Islington, closer to Downtown, and walk to my house rather than park a few feet from my house. My house is .5 miles from Jumpin' Jays and I had to move my friends' and family's cars every 2 hours throughout the program. They could park on State St or on Salem St all day, which are between .1 and .3 miles from Jumpin' Jays, but not at my house a whole half mile away.

Of course Hanover St has limited parking. There are multiple 3 and 4 story apartment complexes on that 2 block stretch of road, and they are .1 to .2 miles from Jumpin' Jays. Maybe we could just have parking permits on Hanover St and Sudbury St because of spillover? The Foundry garage proved that people aren't going to park a third of a mile away from their destination, ie: the distance from 230 McDonough St to Hanover St, where the parking problem is. Maybe a more equitable solution in the future is a parking program for everyone who lives within half a mile of Market Square vs targeting the whole neighborhood because of a small section of that neighborhood having some parking complaints.

Thanks for your time, and all your hard, volunteer work. I think you are all doing a wonderful job that is often times thankless.
Sincerely, Drew Martin

230 McDonough St

Please indicate if you would like your comment to be part of the public record for the upcoming City Council meeting. Yes

Submitted on Sun, 12/11/2022 - 17:13

Full Name

Gabe DiSaverio

Email

gabe@thespicyshark.com

Subject

Budget Proposal - Safety in our Elementary Schools

Address

9 Falkland Place, Unit B1

Message

Portsmouth City Council Members,

My name is Gabe DiSaverio, and I am a Portsmouth resident, local small business owner, and father of a New Franklin kindergarten student. Although last week's active shooter threat was thankfully a hoax, I don't think anyone would disagree that real school shootings are not ending, and will probably increase in velocity. I speak for many parents when I assert that there is no better use of the city's budget dollars than doing everything possible to protect the lives of our children. Although I am grateful that Portsmouth high school and middle school have armed resource officers, we cannot wait any longer to implement them in all 3 Portsmouth elementary schools.

I am unaware of the rationale for cutting elementary resource officers out of the budget in the early 2000's, but I'm also unaware of any logical reason not to bring them back in 2023. Although there are many schools of thoughts regarding how to prevent school shootings, there is no better way to stop one once it has begun, than meeting the threat with existing force. In addition, many studies have shown that

the knowledge of having an armed officer in the school is a deterrent to these shooters, as their goal and motivation is mass death and destruction. I have had Portsmouth teachers tell me that having an armed officer in the school is not intimidating to the students, rather it helps bring community and trust between the children and police department.

In addition to the implementation of armed school resource officers in the 3 elementary schools, I would propose replacing the glass in the front doors of all Portsmouth schools with bullet-proof glass as an added safety measure. I sincerely hope you will consider the content of this message, and add these requests to the budget.

Thank you,

Gabe DiSaverio

Please indicate if you would like your comment to be part of the public record for the upcoming City Council meeting. Yes

Submitted on Tue, 12/13/2022 - 15:17

Full Name

Jana Goldstein

Email

janakgoldstein@gmail.com

Subject

Reinstating school resource officers at the elementary schools

Address

170 F W Hartford Dr

Message

Hello City Council Members,

I am writing to you on behalf of a few voices in our elementary community. In early November Officer Cummings from the Portsmouth Police Department offered an ALICE training information night to families of Dondero students. Although the main focus of the evening was obviously the ALICE protocols and drills, there was some conversation about School Resource Officers and why we no longer have them at the elementary level in Portsmouth.

Of course the role of a School Resource Officer certainly extends past the duty of ALICE training. It was in that part of the meeting that we got slightly off topic, reflecting on the many benefits that School Resource Officers bring to a school community. I currently work in a school in the seacoast area that has a SRO and he is often chatting with students during his lunch and recess duties, offering a classroom break to those students who may be in need of one and instead taking time to shoot hoops, play cornhole, or go on a walk around the school. He is leading our staff in ALICE training, offering safety lessons and tips to students, and holding parent information nights on various topics. He is far from an disciplinary figure, but rather another positive adult within the community who offers support and guidance to all students and just happens to be wearing a uniform. From a young age, students are building a positive relationship with an officer and in turn I feel we are cultivating community.

Portsmouth too used to offer this experience to its elementary students and I have attached an article about the famous "Officer Friendly" and the footprints he left on the community. In this time of trying to rebuild the community after some atypical years in education with COVID, I feel bringing back the SROs to the elementary schools is another way we can grow a stronger school community. A SRO can offer support to the students by being another figure who takes the time to truly connect with them, and support them whether it be social, emotional, mental, economic or other challenges. It is without a doubt that an SRO needs to be selected carefully to match the school's need and student population. With the right person in that position, elementary students will enter middle school already familiar with the role of an SRO in schools and have that rapport with them.

It goes without saying, that in addition to all of the many strengths an SRO can bring to the elementary school, one that is of timely importance after last Thursday, is the added layer of security and safety for our youngest learners and their teachers. I know teaching in a school with a SRO brings me a bit more peace of mind in these uneasy times.

I understand this is a City Budget matter, however I felt it was important to share my feelings on this matter with the School Board as well. I hope that you will take the time to read the article about "Officer Friendly" and reflect on the benefits a SRO could bring to our elementary school communities. Finally, I have attached the petition that was written by Mariah Morgan, fellow Dondero mother, with the help of Molly Wilson. She shared this last Thursday and already we have nearly 200 signatures.

Sincerely,

Jana Goldstein

<https://www.seacoastonline.com/story/news/2004/11/29/officer-friendly-readies-for/50246646007/>

https://www.change.org/p/hire-an-sro-for-portsmouth-nh-elementary-schools?recruiter=1065844983&recruited_by_id=2cf5d730-708d-11ea-bb17-e3091ed342b8&utm_source=share_petition&utm_campaign=share_for_starters_page&utm_medium=copypink

Please indicate if you would like your comment to be part of the public record for the upcoming City Council meeting. Yes

Submitted on Tue, 12/13/2022 - 20:26

Full Name

Gerald Duffy

Email

gduffy44@gmail.com

Subject

McIntyre Project — Supplementary Appropriation

Address

428 Pleasant St, #3

Message

Dear Mayor and Councilors:

Just a couple of comments as you prepare to vote on whether or not to pass a supplemental appropriation for ongoing expenses regarding the McIntyre project, funding meant to see us through another three months of consulting and negotiating. Before you commit more funds to this project, I urge you to wait until the public has a better idea of our potential financial burden. Now that we have some idea of the range of project costs, the game has changed yet again.

Working with what we know . . .

- the legally contracted guarantee of a 7.4% return on investment for the developer
- the projected range of costs to build the project — between \$74 million and \$147 million
- a rough estimate of the current design's projected revenues for the developer from leases etc.

. . . we can roughly calculate how much Redgate Kane will need to invest to get its ROI. Deduct that amount from the overall cost of the project and you have the city's share. Even the lower range of possibilities does not look promising. Unless my math is entirely wrong, it seems very unlikely that the city will be able to identify anywhere near enough "public benefit" to justify the kind of contribution we will have to make. By contrast, the city's purchase of the Community Campus for \$10 million offered a great deal of obvious and tangible public benefit. The McIntyre project is shaping up to cost us a great deal more than that.

Faced with this new financial picture, I hope you are considering creative alternative options to the current plan that will 1) give the residents clear value for money in terms of public benefit and 2) keep us out of the courts and endless legal battles, which given our track record would be pure folly and tie up the property for years. Above all, I hope you can be as forthright as possible with the public, explain our legal obligations in plain terms, describe the options and hard choices available to us, and be bold in making the tough decisions ahead.

Regards and season's greetings,

Gerald Duffy

Please indicate if you would like your comment to be part of the public record for the upcoming City Council meeting. Yes

Submitted on Sat, 12/17/2022 - 13:14

Full Name

Jane Shouse

Email

Shouse555@comcast.net

Subject

Outdoor Dining

Address

555 Dennett Street

Message

I note that discussions have begun about possible changes to outdoor dining for downtown Portsmouth in 2023. I would like to express my frustration with the road closure on Pleasant Street for the Clipper Tavern. I feel that is a big inconvenience and redirects traffic unnecessarily. I overall support outdoor dining and hope it continues to be successful.

Thank you for your consideration.

Please indicate if you would like your comment to be part of the public record for the upcoming City Council meeting. Yes

Submitted on Mon, 12/19/2022 - 18:30

Full Name

Anne Hemmings

Email

akhemmings@gmail.com

Subject

Holiday Parking

Address

24 Market Street

Message

Hello,

As a Portsmouth homeowner and business owner, I am grateful for a time of complimentary parking over the holidays (thank you) but I've received almost hourly feedback regarding the 'free' aspect of the Holiday parking. Very few drivers are aware that parking is free (and as a result knowingly pay for parking), and very few are aware of what the time constraints are. Every year, when this is debated/discussed by the Councilors, the potential 'lost' cost of parking during the proposed time period is discussed. I think it's important to disclose the amount of Parking revenue the Parking Dept. STILL GENERATES during this 'free' period. Please share this amount for the last 5 years that 'free' parking has been offered. Nearly every driver I've conversed with has paid for parking, without having been made aware that it was free. I am sure I am not alone in feeling that some sort of communication on every parking kiosk and meter would not only be fair, transparent, and communicative, but the morally right thing to do. No one likes to be deceived, especially by local (elected) leaders. Thank you for your time and attention. Best, Anne Hemmings

Please indicate if you would like your comment to be part of the public record for the upcoming City Council meeting. Yes

Submitted on Tue, 12/27/2022 - 16:19

Full Name

Scott Bornstein

Email

werscoraja@yahoo.com

Subject

The "Mac"

Address

42 Squid St

Message

Councilor;

I am writing to you in regards to the "MacIntyre" project, which our Mayor has rightfully stated that it is time to resolve, and not pass on to future Council(s). Were it not for my deep fear of public speaking I would appear before you.

I do not know how many of you read these letters, or consider the input citizens give when voting on these issues, but I must convey my opinion on this matter and hope it will be heard.

First, let's state some undisputable facts. All money spent to this date has been spent. It's not coming back. Used for litigation, studies, fees, expenses, surveys, or any other related cost, that money is gone. Redgate has made money no matter where this goes. The city has spent money it will never recover. In history, few projects have ever come in under or at budget from the time of conception to the time of completion. It is fair to raise any proposed cost projection presented, literally by nearly any factor, at this time when considering the final cost to the city and its residents.

Kenny Rogers wrote "you've got to know when to hold 'em, know when to fold 'em, know when to walk away, and know when to run." It is time for our city to step away, with authority and clarity. Money lost is gone, and the potential appears limited for this to be a project that ends in the favor of the city. EVERYONE involved in this project is in it for the money, and most expect that to come from the taxpayers, whether they say so publicly or not. There is no win here for us, only a fantastic opportunity to cut our losses.

The concept of an enormous structure and prime piece of land has been dangled before us, as many other locations have faced. We have begun to see the harsh realities of an offer "that's too good to be true". Councilor, it is not the dream ticket it appeared to be, and the time to step away is now. Take the loss, prevent further damage, retake control, and with chin raised, walk away from this venture. Any decision to move ahead, would, in fact, punt further future decisions to other Councils.

Thank you for your time, effort and dedication to our city.

Scott H Bornstein

Please indicate if you would like your comment to be part of the public record for the upcoming City Council meeting. Yes

Submitted on Sat, 12/31/2022 - 11:39

Full Name

Lillian Seitz

Email

liliem@comcast.net

Subject

McIntyre Redevelopment

Address

20 Taylor Ln

Message

We are writing to inform you that we are opposed to the city spending any more money on the McIntyre redevelopment and associated projects. Also, we want to express our support for keeping the Post Office on Heritage Ave. It is vitally important to have a post office that is easily accessible and convenient and with appropriate parking especially for senior citizens and the disabled. This is a must for the citizenship of Portsmouth!

Sincerely, Lillian and Kenneth Seitz

Please indicate if you would like your comment to be part of the public record for the upcoming City Council meeting. Yes

Submitted on Mon, 01/02/2023 - 16:18

Full Name

Liz and Tom Mooney

Email

ellizabethvmooney@hotmail.com

Subject

McIntyre Federal Building

Address

176 Woodlawn Circle

Message

Dear Mr. Mayor and City Councilors:

We were neutral about this plan until the fine print came into focus recently. Call it sticker shock. This is the most expensive \$1 purchase ever. Walk away!

Let the U.S. Government auction it off. It is a federally designated historic monument in a city-defined historic district. Design covenants are in place twice over.

McIntyre stands in a prime location in high demand. There is absolutely no justification for the middle class to subsidize the wealthy. The plan calls for market rate housing and retail space, both of which are in oversupply, here and nationwide. Let us not forget inflation.

It is obvious the cost-benefit analysis doesn't work. Otherwise, any developer would obtain private financing and assume all risks.

Instead, city taxpayers would be on the hook for a substantial portion of construction costs. Worse yet, the developer demands Portsmouth taxpayers underwrite its risk by guaranteeing a minimum rate of return.

All this on the nebulous assertion that a property which never paid local taxes might someday - who knows when - generate enough property tax revenue to repay the enormous up-front subsidy burdening this generation of taxpayers. Just say "No."

It would be far better and wiser to invest our hard-earned tax dollars in a new police station and affordable housing at the Community Campus.

Please indicate if you would like your comment to be part of the public record for the upcoming City Council meeting. Yes

Submitted on Tue, 01/03/2023 - 17:17

Full Name

charlie griffin

Email

charlesgriffinesq@mail.com

Subject

McIntyre Project

Address

210 Hillside Drive

Message

In deciding whether to request a supplemental appropriation for additional expenses related to the development of the McIntyre Project at your meeting on Monday night, I ask you to consider the following.

There is no free lunch. While the idea of acquiring the McIntyre building from the GSA for free or \$1 seemed very appealing when first floated by then Senator Judd Gregg in 2005, the subsequent passage of time, the imposition of design conditions by the GSA and the expenditure of millions of taxpayer dollars has proven that when something seems too good to be true ,it is.

There is a difference between a need and. want .A need is something the City must have ,such as a new Police Station. A want on the other hand is something the City wishes to have ,namely the McIntyre building and subsequent redevelopment of the site, but can no longer afford given the projected costs and therefore must abandon.

The City should not be in the development business. Development is the role of the private sector and the City's role should be limited to oversight and review(Site Review, HDC Approval, etc.).However, the City finds itself having entered into the equivalent of a pre nuptial agreement with a private developer which obligates the taxpayers to pay the alimony..

However, if you still want to pursue acquiring the McIntyre site, rather than approving the additional \$150,000 expenditure , you need to adopt a completely new plan which consists of arriving at a settlement with the developer to end its partnership with the City, approaching the GSA to acquire the property to develop it as the site of a new Police Station and Fire Station, approaching the US Postal Service to return the Post Office to its former downtown location and selling the Court Street Fire Station and applying the net proceeds to the new McIntyre project redevelopment costs.

As always, I thank you for your consideration and would like my comments to be included as part of the public record for your upcoming January 9 meeting.

Please indicate if you would like your comment to be part of the public record for the upcoming City Council meeting. Yes

**Perry Silverstein
P.O. Box 91
Portsmouth, NH 03802**

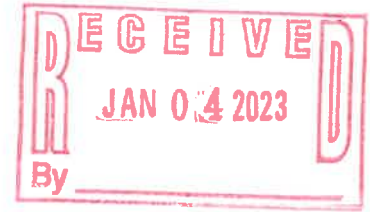

Portsmouth City Council members,

1/3/2023

At the start of Covid everybody agreed that the restaurants needed help. This help included the taxpayers giving up parking revenue for outside dining. Retailers gave up much needed customer parking, and many others made sacrifices to help the restaurants.

Covid restrictions are over. The parking spaces have been so inexpensive that some restaurants hardly used them, and made no effort to make them attractive. They didn't have enough skin in the game. I believe that is what Mayor McEachern said at the last meeting... 'the restaurants need to have skin in the game'.

Most Portsmouth restauranteurs did great right through Covid. They received a lot of PPP money and Main Street program funding. Many did so well during Covid, that they expanded and opened new restaurants. The restaurants now are so busy it's hard to get a table.

Please take a close look at which restaurants are taking the majority of these parking spots... Are these restauranteurs doing well? Do they need a taxpayer handout? Can they afford to pay a fair amount? Should private businesses, and selectively only the restaurants, be subsidized with taxpayer money? Do we need to shut down travel lanes and create traffic issues?

Please don't confuse this year's scheduled fee of \$3,000 as some kind of surprise doubling that restaurants aren't prepared for. It is a continued scheduled agreed upon reduction, and not a 'doubling of the fees'. It is still a bargain and reduction of about 50% of what was recommended last year.

I was a long time downtown resident and retailer in Portsmouth with 2 downtown stores. I'm now a taxpayer and landlord to both retailers and restaurants. I do understand first hand the impact this has on the merchants, residents, and taxpayers. It needs to be fair to everybody.

With the McIntyre expenses coming soon, the City has to look to stop the bleeding. Some councilors feel that a few hundred thousand dollar deficit to give restaurants parking spaces isn't a big deal? It is a big deal.

Many of us hope the City Council will be responsible and fair when making decisions. Those of us that pay the property taxes, including the retailers, other businesses, and residents need the City to think of everybody, and not favor one industry over others.

Thank you. Happy New Year.

Perry Silverstein

cc: Mayor McEachern, City Manager Karen Conard, downtown merchants...

Gift and Donation Submission Form

Donations received by the City of Portsmouth must be accepted by the City Council. Please complete this form and submit it to the City Manager for inclusion on an upcoming agenda.

Date:	December 23, 2022
Department/ Contact Person:	Peter Rice, Director of Public Works
Donation Amount:	\$25.00

Are Funds to be directed to a particular department, program or fund? – If yes, please provide detail below:

Tree Fund

Is there a particular purpose intended with this donation:

To honor Lisa Gellhood who is a Tree Warden in the UK and sister of the donor.
--

Other Information/Special Conditions:

--

Donor Information

First & Last Name:	Judith A. Sabin
Business Name:	
Address*:	126 #1 Wibird Street
Phone*:	603-396-5653
Email*:	

Please note that gifts/donations to individual employees with a value of \$100 or more are not permitted. Information with an asterisk () indicates it will not be publicly distributed.*

Gift and Donation Submission Form

Donations received by the City of Portsmouth must be accepted by the City Council. Please complete this form and submit it to the City Manager for inclusion on an upcoming agenda.

Date:	12.11.2022
Department/ Contact Person:	Portsmouth Fire Department Fire Chief William McQuillen
Donation Amount:	\$2,500.00

Are Funds to be directed to a particular department, program or fund? – If yes, please provide detail below:

Yes. Portsmouth Fire Department

Is there a particular purpose intended with this donation:

No. At Department Discretion

Other Information/Special Conditions:

Donor Information

First & Last Name:	Paul Gormley & Kimi Iguchi
Business Name:	
Address*:	
Phone*:	
Email*:	

Please note that gifts/donations to individual employees with a value of \$100 or more are not permitted. Information with an asterisk () indicates it will not be publicly distributed.*

Gift and Donation Submission Form

Donations received by the City of Portsmouth must be accepted by the City Council. Please complete this form and submit it to the City Manager for inclusion on an upcoming agenda.

Date:	12/12/22
Department/ Contact Person:	Portsmouth Senior Activity Center Nicole Finitis, Senior Services Coordinator
Donation Amount:	\$5,000

Are Funds to be directed to a particular department, program or fund? – If yes, please provide detail below:

Specifics are mentioned that these dollars go back into the Portsmouth Senior Activity Center.

Is there a particular purpose intended with this donation:

Senior Luncheon Funds – general use of special meals and programs that come out of our senior luncheon fund.

Other Information/Special Conditions:

Donor Information

First & Last Name:	Anne Aoki
Business Name:	
Address*:	14 Hampton Meadows, Hampton, NH 03842
Phone*:	603-601-0567
Email*:	taxesgal@aol.com

Gift and Donation Submission Form

Please note that gifts/donations to individual employees with a value of \$100 or more are not permitted. Information with an asterisk () indicates it will not be publicly distributed.*

