

40 PLEASANT STREET

40 PLEASANT STREET
HISTORIC DISTRICT COMMISSION
PUBLIC HEARING - 08/19/2022

DESIGN INTENT:

- REPLACE EXISTING WINDOWS WITH NEW WINDOWS THAT UPHOLD THE HISTORICAL APPEARANCE OF THE CUSTOM HOUSE
- REMOVE EXISTING CANVAS AWNINGS AND CONSTRUCT NEW STEEL AND GLASS AWNINGS AT PLEASANT, CHURCH, AND STATE STREET ENTRANCES
- REPLACE EXISTING ENTRY DOOR WITH NEW DOOR AND FRAMES THAT UPHOLD THE HISTORICAL APPEARANCE OF THE CUSTOM HOUSE
- REPLACE CURRENT SIGNAGE WITH NEW SIGNAGE THAT BETTER RESPECTS THE BUILDING ARCHITECTURE
- INSTALL NEW EXTERIOR LIGHTING TO ENHANCE THE FACADES AT NIGHT

SITE LOCATION MAP:

BUILDING LOCATION

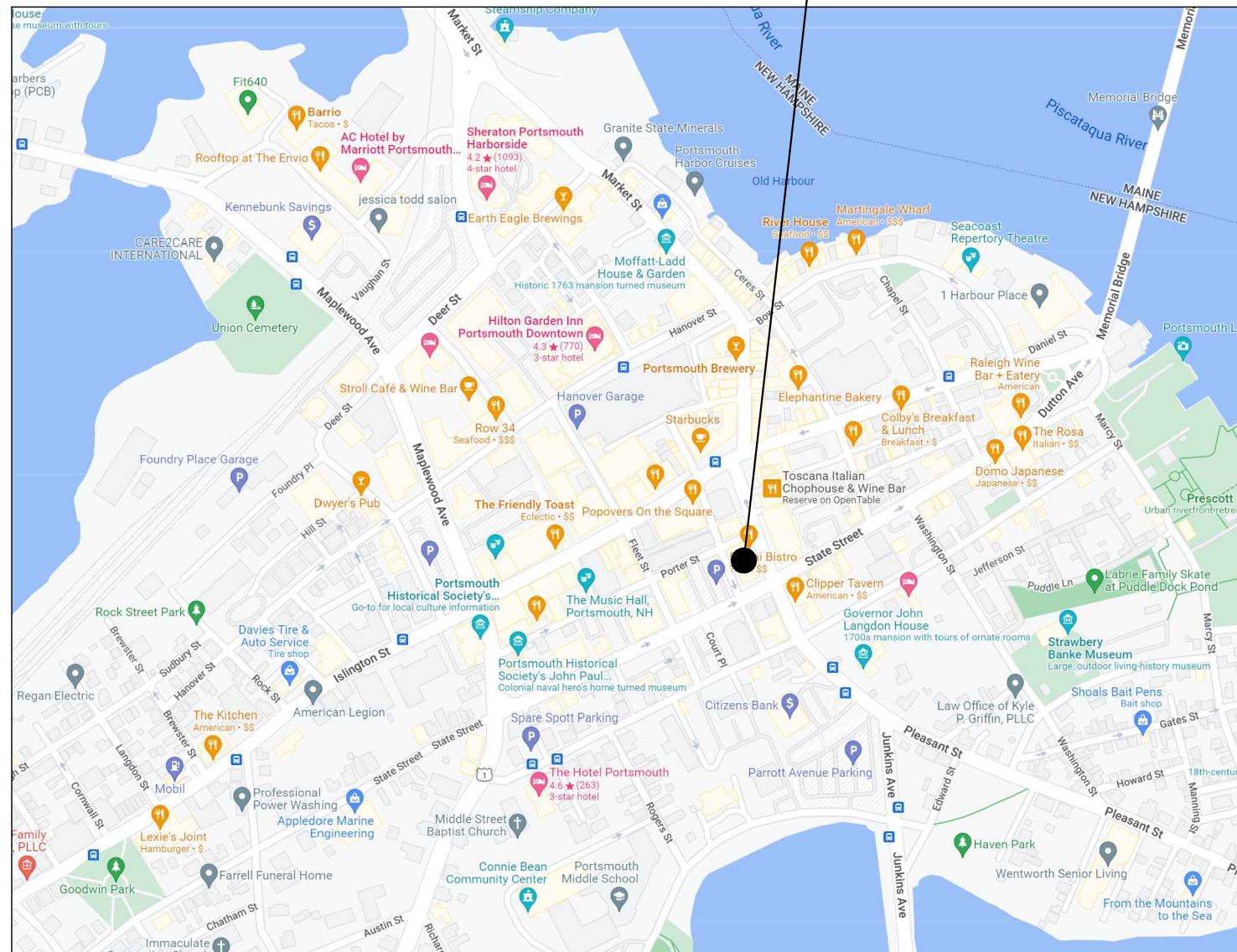

DRAWING INDEX:

GENERAL

- T0.1 TITLE SHEET
- T1.0 CONTEXT – HISTORIC
- T1.1 CONTEXT – EXISTING

EXISTING DRAWINGS

- AE1.0 EXISTING GROUND PLAN
- AE2.0 EXISTING NORTH ELEVATION
- AE2.1 EXISTING EAST ELEVATION
- AE2.2 EXISTING SOUTH ELEVATION
- AE2.3 EXISTING WEST ELEVATION

ARCHITECTURAL DRAWINGS

- A2.0 PROPOSED NORTH ELEVATION
- A2.1 PROPOSED EAST ELEVATION
- A2.2 PROPOSED SOUTH ELEVATION
- A2.3 PROPOSED WEST ELEVATION
- A5.0 SECTIONS AND DETAILS
- A5.1 SECTIONS AND DETAILS
- A5.2 SECTIONS AND DETAILS
- A5.3 SECTIONS AND DETAILS
- A6.0 PERSPECTIVE IMAGES
- A7.0 WINDOW TYPES
- A7.1 DOOR TYPES
- A8.0 WINDOW CUT SHEET
- A8.1 LIGHTING CUT SHEET
- A9.0 CANOPY PLAN/INSPIRATION
- A9.1 LIGHTING INSPIRATION

40 PLEASANT STREET
PORTSMOUTH, NH 03801

PROJECT:

KEY:

**WINTER
HOLBEN**

architecture + design

7 WALLINGFORD SQ
UNIT 209-9
KITTERY, MAINE 03904
207.994.3104

REVISIONS:

PROJECT NAME:

40 PLEASANT STREET
40 PLEASANT ST.
PORTSMOUTH, NH 03801

PROJECT NO.: 22065

DRAWN BY: GL/RW

APPROVED BY: BH

ISSUE DATE: 7/21/2022

DRAWING NAME:

TITLE SHEET

SCALE:

DRAWING NO.:

T0.1

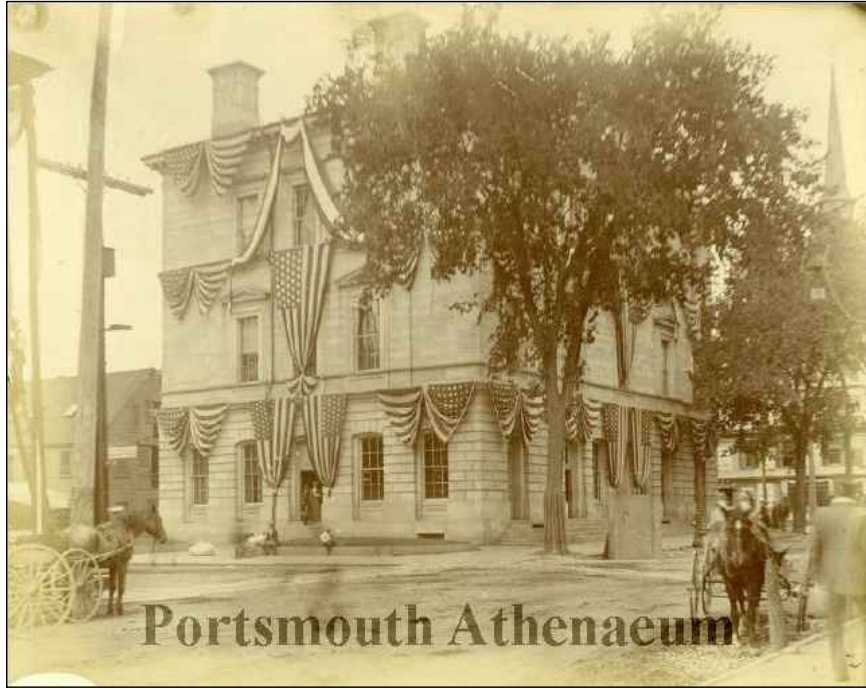

HISTORIC SOUTH EAST BUILDING CORNER

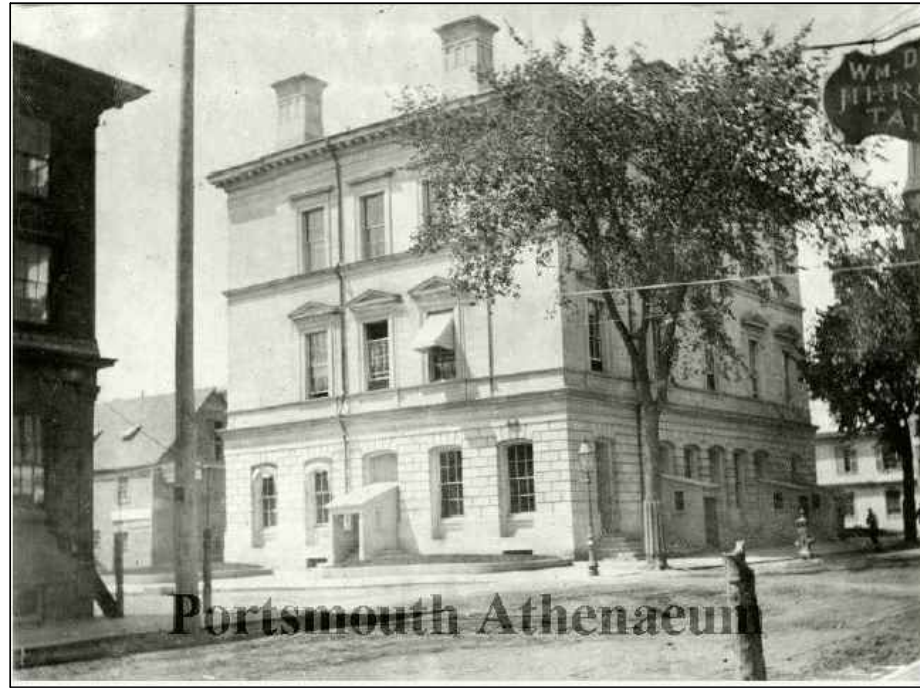

HISTORIC SOUTH EAST BUILDING CORNER

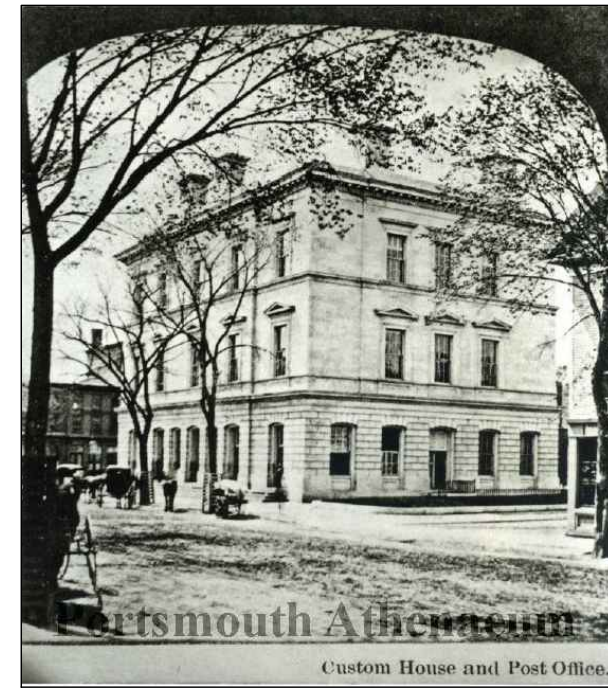

HISTORIC NORTH EAST BUILDING CORNER



HISTORIC EAST ELEVATION

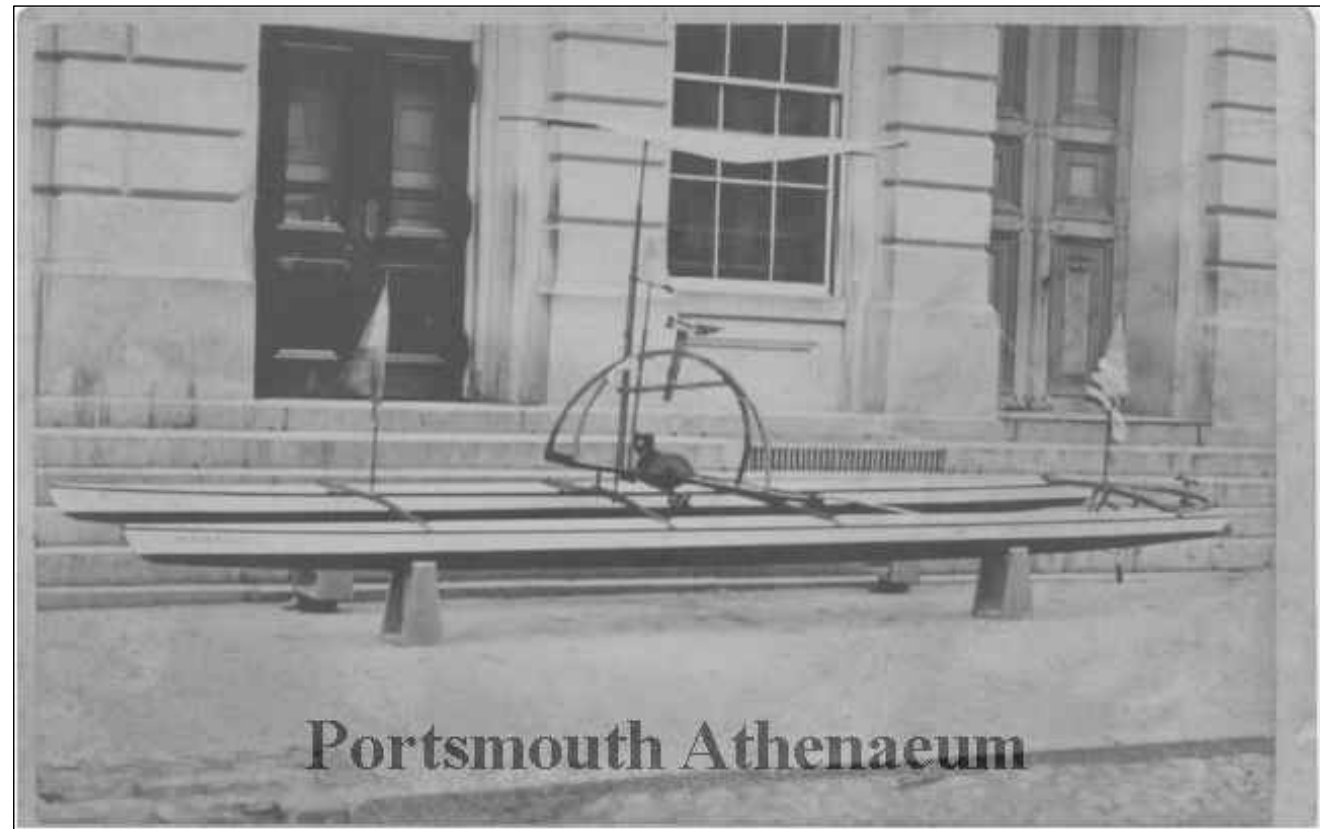

HISTORIC EAST ENTRY

40 PLEASANT STREET
 40 PLEASANT STREET
 PORTSMOUTH, NH 03801

PROJECT:

KEY:

**WINTER
 HOLBEN**

architecture + design

7 WALLINGFORD SQ
 UNIT 209-9
 KITTERY, MAINE 03904
 207.994.3104

REVISIONS:

PROJECT NAME:
 40 PLEASANT STREET
 40 PLEASANT ST.
 PORTSMOUTH, NH 03801

PROJECT NO.: 22065
 DRAWN BY: GL/RW
 APPROVED BY: BH
 ISSUE DATE: 7/21/2022

DRAWING NAME:
 CONTEXT -
 HISTORIC

SCALE:

DRAWING NO.:

T1.0



EXISTING NORTH WEST BUILDING CORNER



EXISTING NORTH EAST BUILDING CORNER



EXISTING EAST ELEVATION



EXISTING SOUTH ELEVATION



EXISTING SOUTH EAST BUILDING CORNER



EXISTING WEST ELEVATION

40 PLEASANT STREET
PORTSMOUTH, NH 03801

PROJECT:

KEY:

**WINTER
HOLBEN**
architecture + design

7 WALLINGFORD SQ
UNIT 209-9
KITTERY, MAINE 03904
207.994.3104

REVISIONS:

PROJECT NAME:
40 PLEASANT STREET
40 PLEASANT ST.
PORTSMOUTH, NH 03801
PROJECT NO.: 22065
DRAWN BY: GL/RW
APPROVED BY: BH
ISSUE DATE: 7/21/2022
DRAWING NAME:

CONTEXT -
EXISTING

SCALE:

DRAWING NO.:

T1.1

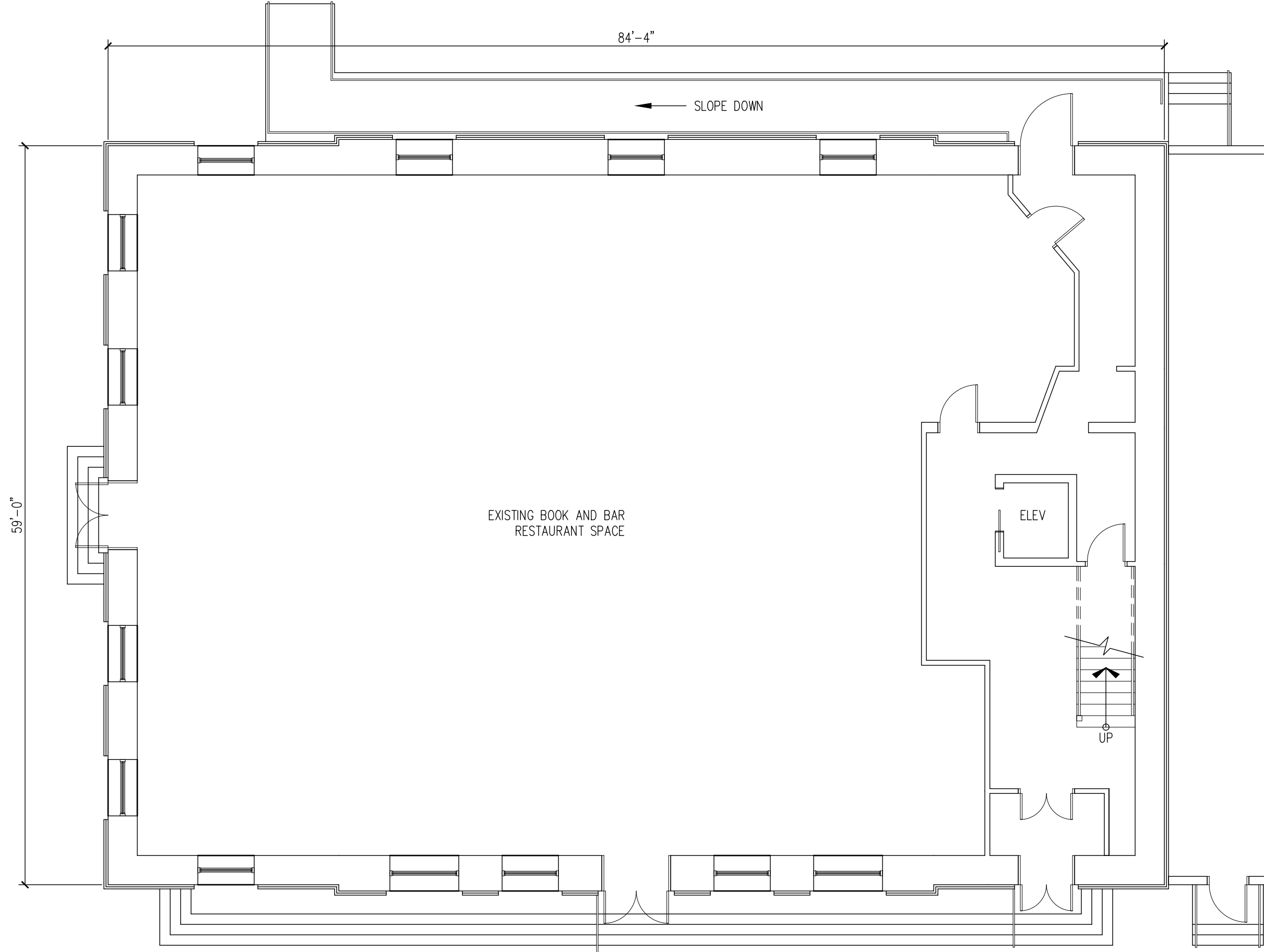

EXISTING BOOK AND BAR
RESTAURANT SPACE

84'-4"
← SLOPE DOWN

59'-0"

ELEV

UP

EXISTING GROUND PLAN
SCALE: 1/8"=1'-0"

AE1.0 1

40 PLEASANT STREET
40 PLEASANT STREET
PORTSMOUTH, NH 03801

PROJECT:
KEY:

**WINTER
HOLBEN**
architecture + design

7 WALLINGFORD SQ
UNIT 209-9
KITTERY, MAINE 03904
207.994.3104

REVISIONS:

PROJECT NAME:
40 PLEASANT STREET
40 PLEASANT ST.
PORTSMOUTH, NH 03801

PROJECT NO.: 22065
DRAWN BY: GL/RW
APPROVED BY: BH
ISSUE DATE: 7/21/2022

DRAWING NAME:
EXISTING GROUND
PLAN

SCALE:
DRAWING NO.:

AE1.0

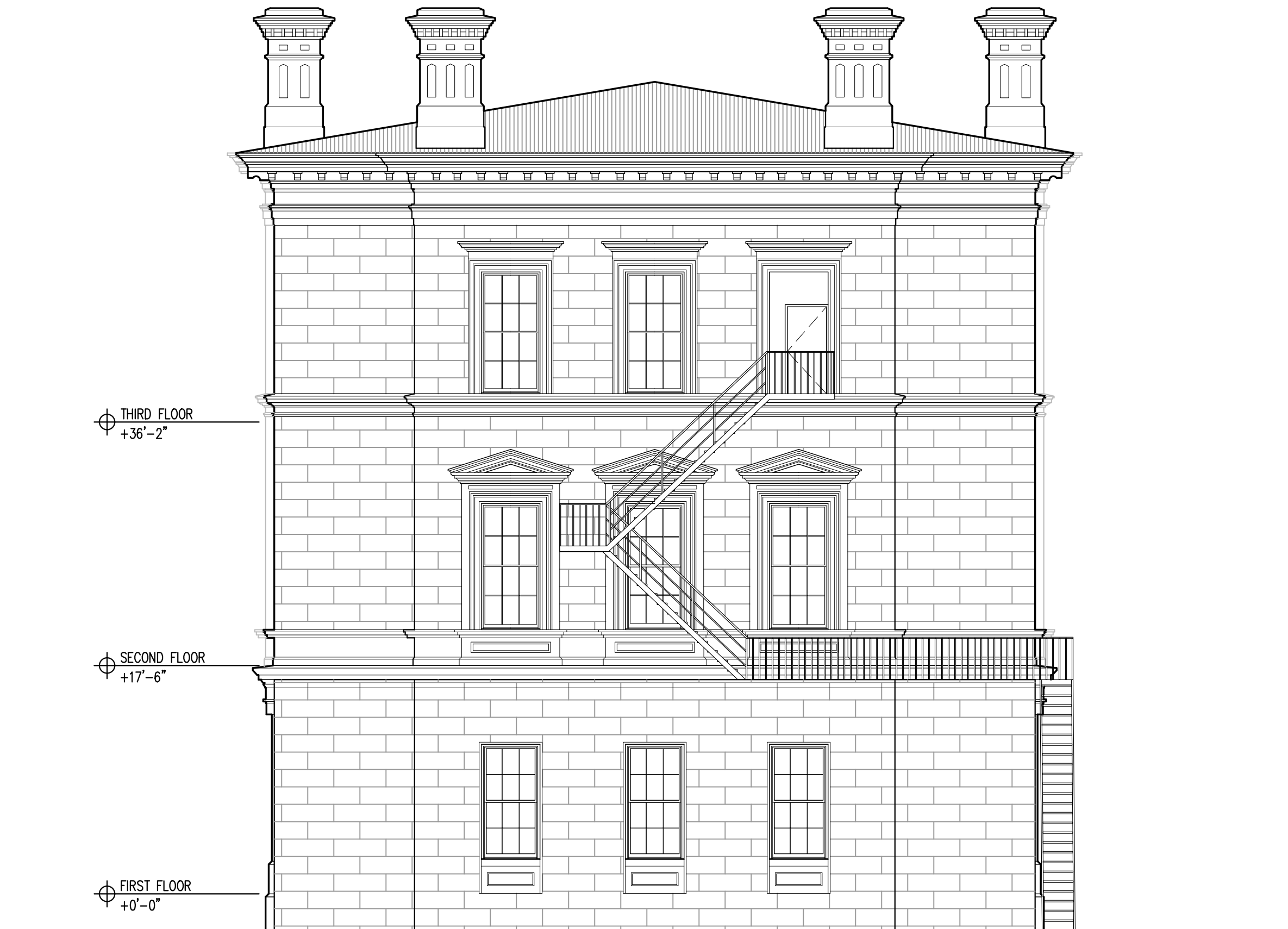

THIRD FLOOR
+36'-2"

SECOND FLOOR
+17'-6"

FIRST FLOOR
+0'-0"

EXISTING NORTH ELEV. (PORTER ST.)
SCALE: 1/8"=1'-0"

AE2.0 1

40 PLEASANT STREET
40 PLEASANT STREET
PORTSMOUTH, NH 03801

PROJECT:
KEY:

**WINTER
HOLBEN**
architecture + design

7 WALLINGFORD SQ
UNIT 209-9
KITTERY, MAINE 03904
207.994.3104

REVISIONS:

PROJECT NAME:
40 PLEASANT STREET
40 PLEASANT ST.
PORTSMOUTH, NH 03801
PROJECT NO.: 22065
DRAWN BY: GL/RW
APPROVED BY: BH
ISSUE DATE: 7/21/2022
DRAWING NAME:
EXISTING NORTH
ELEVATION

SCALE:
DRAWING NO.:

AE2.0



⊕ THIRD FLOOR
+36'-2"

⊕ SECOND FLOOR
+17'-6"

⊕ FIRST FLOOR
+0'-0"

EXISTING EAST ELEV. (PLEASANT ST.)
SCALE: 1/8"=1'-0"

AE2.1 1

40 PLEASANT STREET

40 PLEASANT STREET
PORTSMOUTH, NH 03801

PROJECT:
KEY:

**WINTER
HOLBEN**
architecture + design

7 WALLINGFORD SQ
UNIT 209-9
KITTERY, MAINE 03904
207.994.3104

REVISIONS:

PROJECT NAME:
40 PLEASANT STREET
40 PLEASANT ST.
PORTSMOUTH, NH 03801
PROJECT NO.: 22065
DRAWN BY: GL/RW
APPROVED BY: BH
ISSUE DATE: 7/21/2022
DRAWING NAME:
EXISTING EAST
ELEVATION

SCALE:
DRAWING NO.:

AE2.1

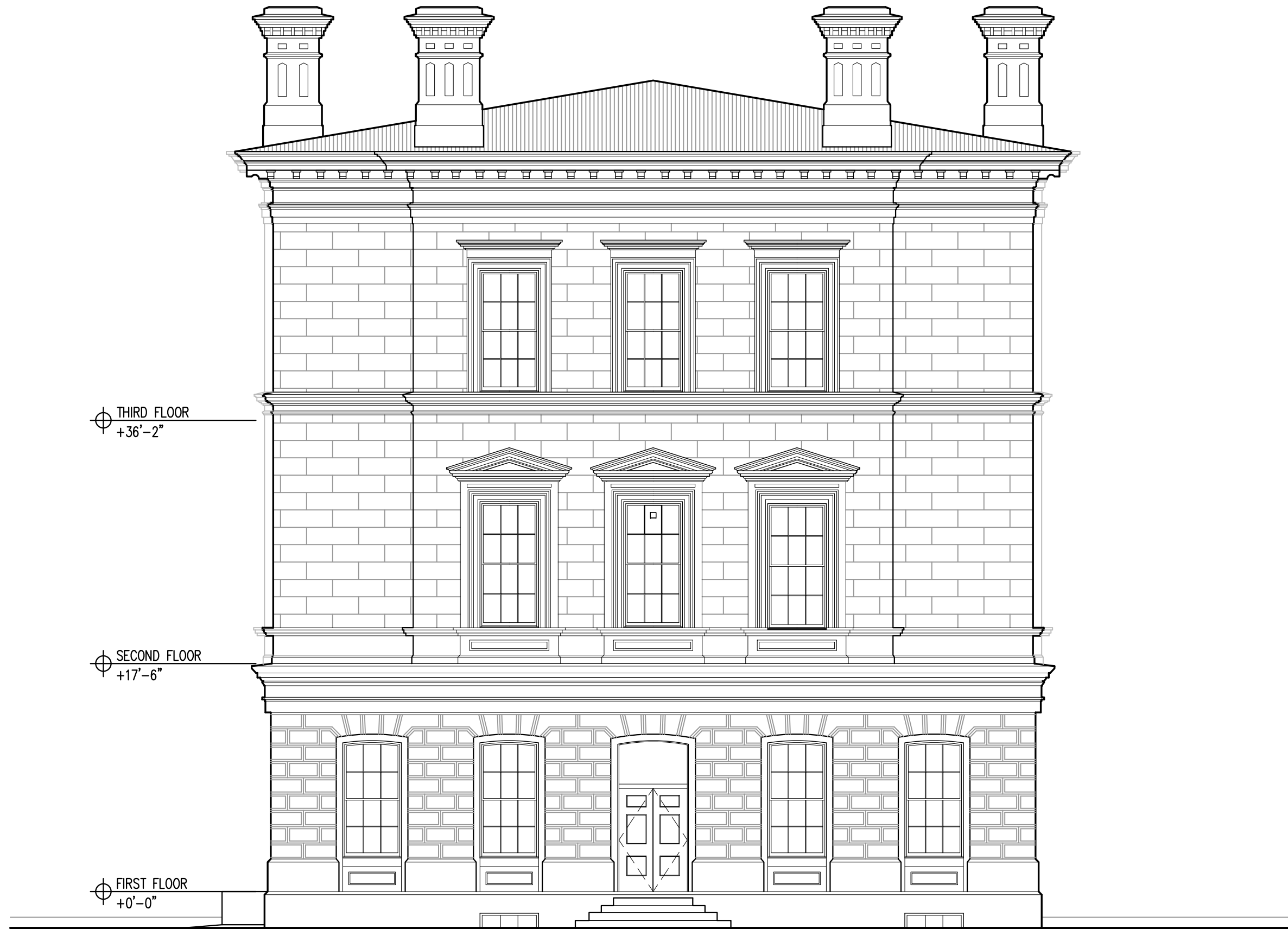

⊕ THIRD FLOOR
+36'-2"

⊕ SECOND FLOOR
+17'-6"

⊕ FIRST FLOOR
+0'-0"

EXISTING SOUTH ELEV. (STATE ST.)
SCALE: 1/8"=1'-0"

AE2.2 1

40 PLEASANT STREET
40 PLEASANT STREET
PORTSMOUTH, NH 03801

PROJECT:
KEY:

**WINTER
HOLBEN**
architecture + design

7 WALLINGFORD SQ
UNIT 209-9
KITTERY, MAINE 03904
207.994.3104

REVISIONS:

PROJECT NAME:
40 PLEASANT STREET
40 PLEASANT ST.
PORTSMOUTH, NH 03801

PROJECT NO.: 22065
DRAWN BY: GL/RW
APPROVED BY: BH
ISSUE DATE: 7/21/2022

DRAWING NAME:
EXISTING SOUTH
ELEVATION

SCALE:
DRAWING NO.:

AE2.2



THIRD FLOOR
+36'-2"

SECOND FLOOR
+17'-6"

FIRST FLOOR
+0'-0"

EXISTING WEST ELEV. (CHURCH ST.)
SCALE: 1/8"=1'-0"

AE2.3 1

40 PLEASANT STREET
40 PLEASANT STREET
PORTSMOUTH, NH 03801

PROJECT:
KEY:

**WINTER
HOLBEN**
architecture + design

7 WALLINGFORD SQ
UNIT 209-9
KITTERY, MAINE 03904
207.994.3104

REVISIONS:

PROJECT NAME:
40 PLEASANT STREET
40 PLEASANT ST.
PORTSMOUTH, NH 03801
PROJECT NO.: 22065
DRAWN BY: GL/RW
APPROVED BY: BH
ISSUE DATE: 7/21/2022
DRAWING NAME:
EXISTING WEST
ELEVATION

SCALE:
DRAWING NO.:

AE2.3

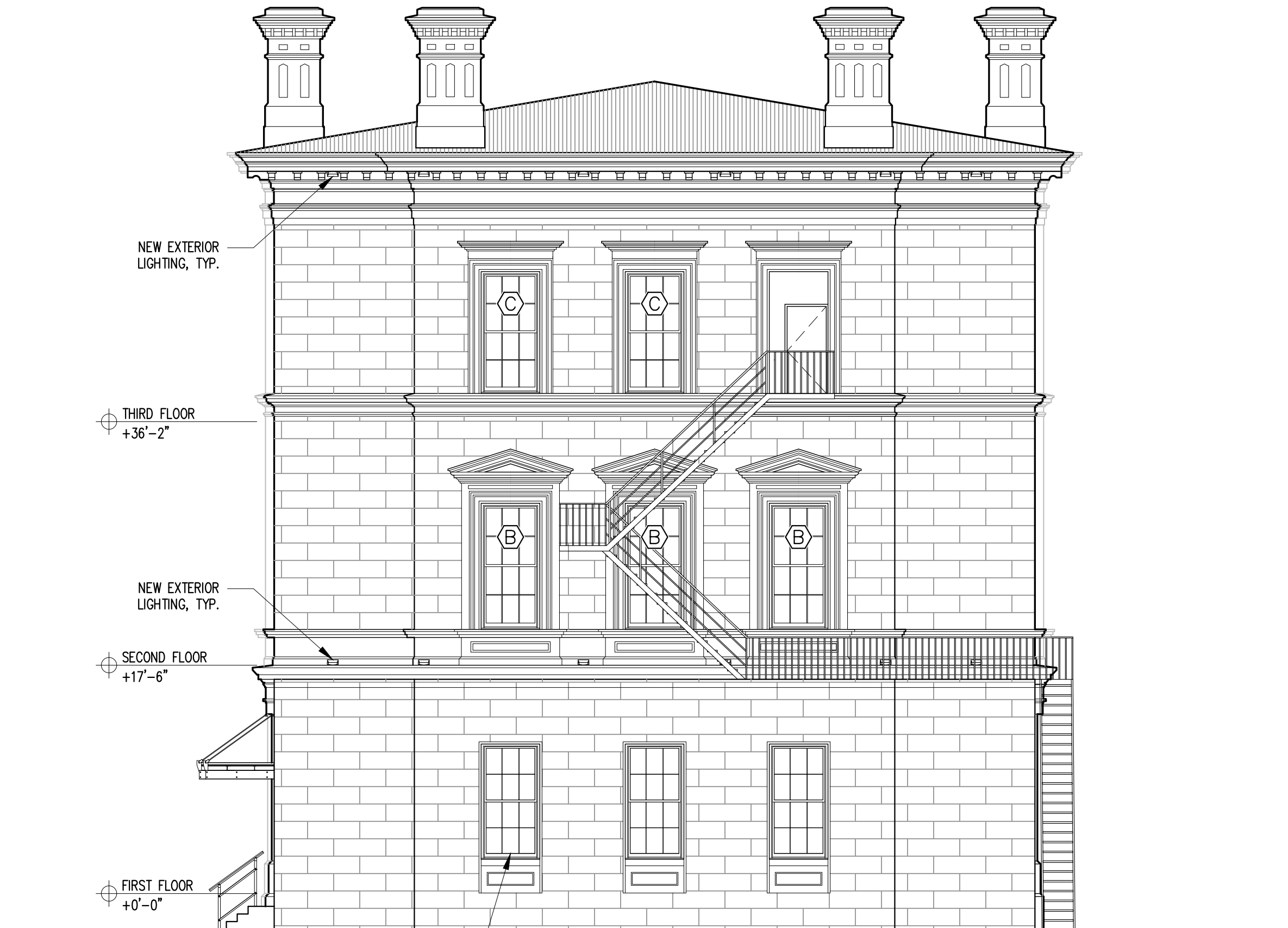

NEW EXTERIOR LIGHTING, TYP.

THIRD FLOOR
+36'-2"

NEW EXTERIOR LIGHTING, TYP.

SECOND FLOOR
+17'-6"

FIRST FLOOR
+0'-0"

PAINT AND REPAIR EXISTING WINDOWS,
TYPICAL FOR 5 THAI WINDOWS

PROPOSED NORTH ELEV. (PORTER ST.)
SCALE: 1/8"=1'-0"

A2.0 1

40 PLEASANT STREET
40 PLEASANT STREET
PORTSMOUTH, NH 03801

PROJECT:
KEY:

**WINTER
HOLBEN**
architecture + design

7 WALLINGFORD SQ
UNIT 209-9
KITTERY, MAINE 03904
207.994.3104

REVISIONS:

PROJECT NAME:
40 PLEASANT STREET
40 PLEASANT ST.
PORTSMOUTH, NH 03801

PROJECT NO.: 22065
DRAWN BY: GL/RW
APPROVED BY: BH
ISSUE DATE: 7/21/2022

DRAWING NAME:
PROPOSED NORTH
ELEVATION

SCALE:
DRAWING NO.:

A2.0

40 PLEASANT STREET
 40 PLEASANT STREET
 PORTSMOUTH, NH 03801

PROJECT:
 KEY:

**WINTER
 HOLBEN**
 architecture + design

7 WALLINGFORD SQ
 UNIT 209-9
 KITTERY, MAINE 03904
 207.994.3104

REVISIONS:

PROJECT NAME:
 40 PLEASANT STREET
 40 PLEASANT ST.
 PORTSMOUTH, NH 03801
 PROJECT NO.: 22065
 DRAWN BY: GL/RW
 APPROVED BY: BH
 ISSUE DATE: 7/21/2022
 DRAWING NAME:
 PROPOSED EAST
 ELEVATION

SCALE:
 DRAWING NO.:

A2.1



PROPOSED EAST ELEV. (PLEASANT ST.)
 SCALE: 1/8"=1'-0" A2.1 1

PAINT AND REPAIR EXISTING WINDOWS,
 TYPICAL FOR 5 THAI WINDOWS

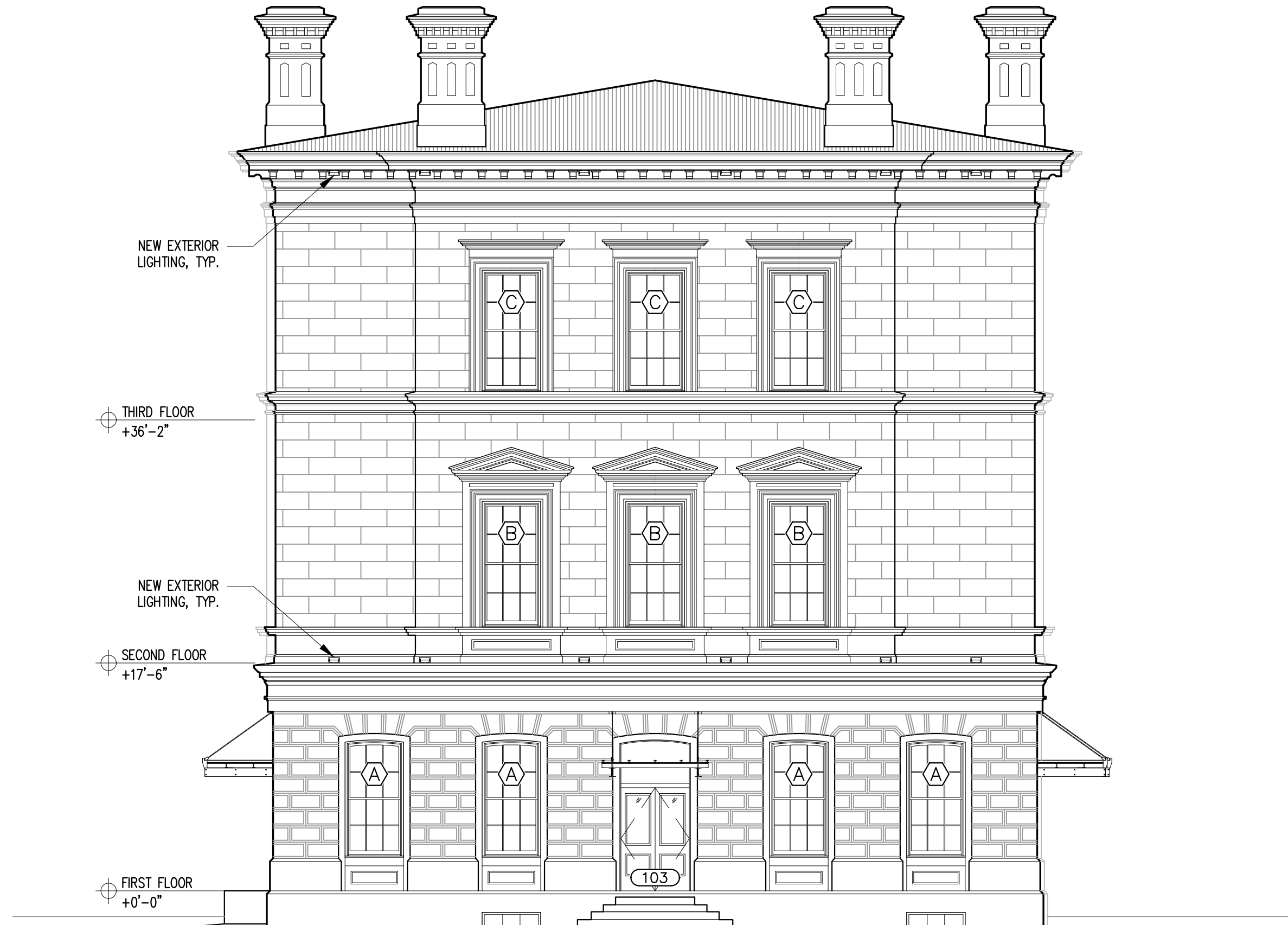

PROPOSED NORTH ELEV. (STATE ST.)
SCALE: 1/8"=1'-0"

A2.2 1

40 PLEASANT STREET
40 PLEASANT STREET
PORTSMOUTH, NH 03801

PROJECT:
KEY:

**WINTER
HOLBEN**
architecture + design

7 WALLINGFORD SQ
UNIT 209-9
KITTERY, MAINE 03904
207.994.3104

REVISIONS:

PROJECT NAME:
40 PLEASANT STREET
40 PLEASANT ST.
PORTSMOUTH, NH 03801

PROJECT NO.: 22065
DRAWN BY: GL/RW
APPROVED BY: BH
ISSUE DATE: 7/21/2022

DRAWING NAME:
PROPOSED SOUTH
ELEVATION

SCALE:
DRAWING NO.:

A2.2

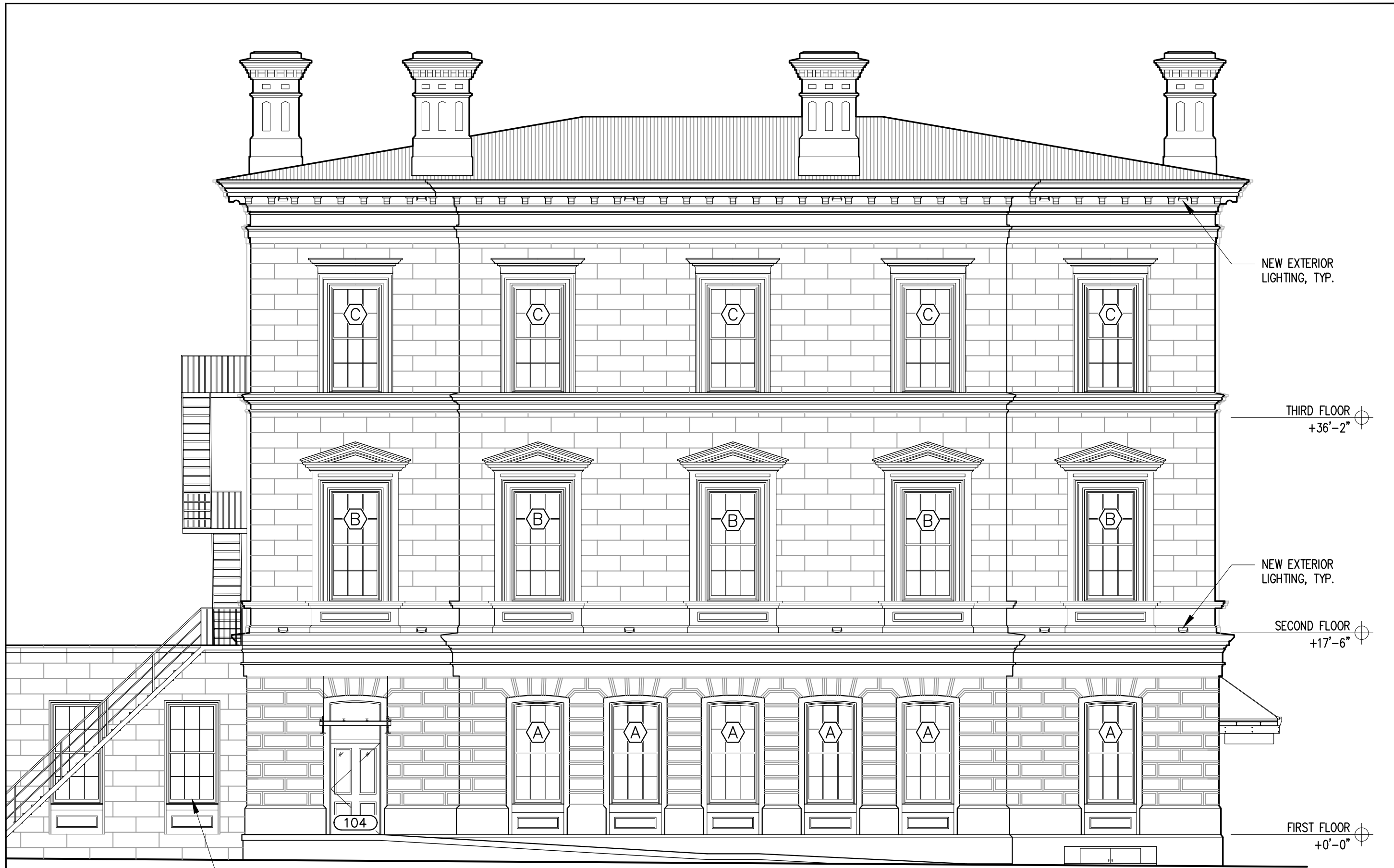

PAINT AND REPAIR EXISTING WINDOWS,
TYPICAL FOR 5 THAI WINDOWS

PROPOSED WEST ELEV. (CHURCH ST.)
SCALE: 1/8"=1'-0"

A2.3 1

40 PLEASANT STREET
40 PLEASANT STREET
PORTSMOUTH, NH 03801

PROJECT:
KEY:

**WINTER
HOLBEN**
architecture + design

7 WALLINGFORD SQ
UNIT 209-9
KITTEERY, MAINE 03904
207.994.3104

REVISIONS:

PROJECT NAME:
40 PLEASANT STREET
40 PLEASANT ST.
PORTSMOUTH, NH 03801
PROJECT NO.: 22065
DRAWN BY: GL/RW
APPROVED BY: BH
ISSUE DATE: 7/21/2022
DRAWING NAME:

PROPOSED WEST
ELEVATION

SCALE:
DRAWING NO.:

A2.3

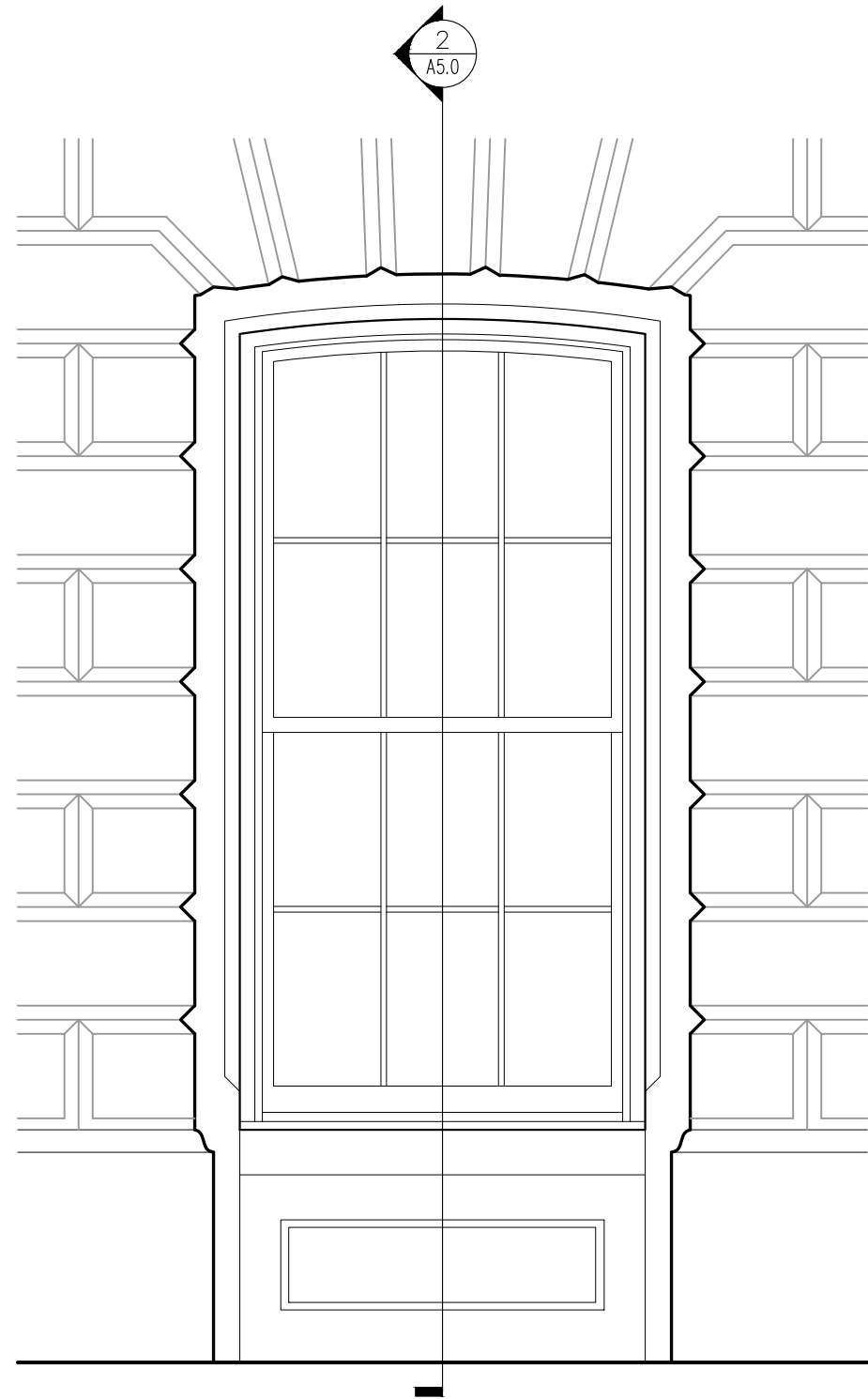

TYPICAL FIRST FLOOR WINDOW ELEV.
SCALE: 1/2"=1'-0"

A5.0 1

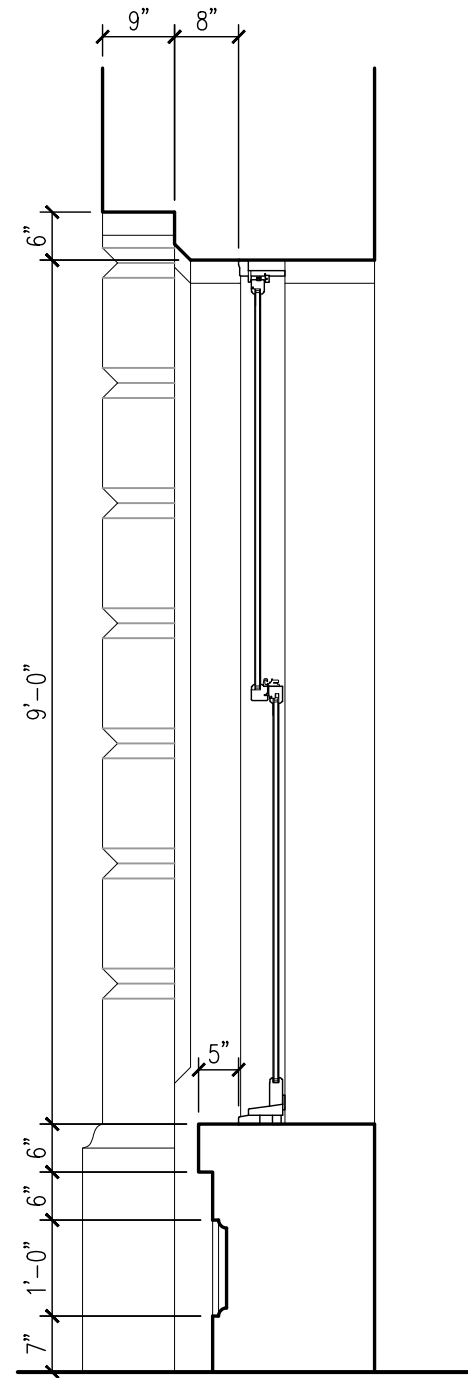

TYPICAL FIRST FLOOR PROFILE
SCALE: 1/2"=1'-0"

A5.0 2

40 PLEASANT STREET
40 PLEASANT STREET
PORTSMOUTH, NH 03801

PROJECT:
KEY:

**WINTER
HOLBEN**
architecture + design

7 WALLINGFORD SQ
UNIT 209-9
KITTERY, MAINE 03904
207.994.3104

REVISIONS:

PROJECT NAME:
40 PLEASANT STREET
40 PLEASANT ST.
PORTSMOUTH, NH 03801

PROJECT NO.: 22065
DRAWN BY: GL/RW
APPROVED BY: BH
ISSUE DATE: 7/21/2022

DRAWING NAME:
FIRST FLOOR
WINDOW DETAIL

SCALE:
DRAWING NO.:

A5.0

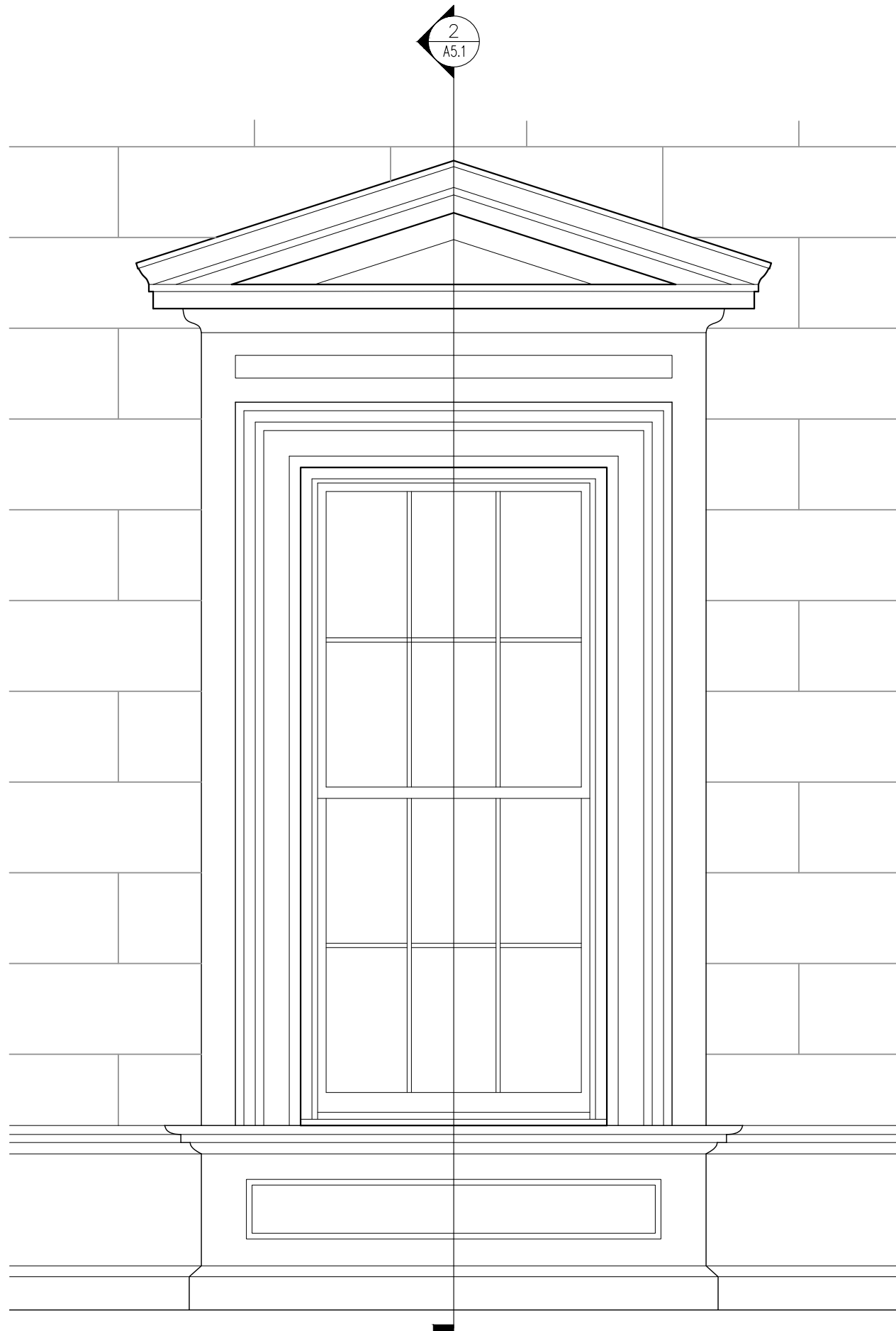

TYPICAL SECOND FLOOR WINDOW ELEV.

SCALE: 1/2"=1'-0"

1

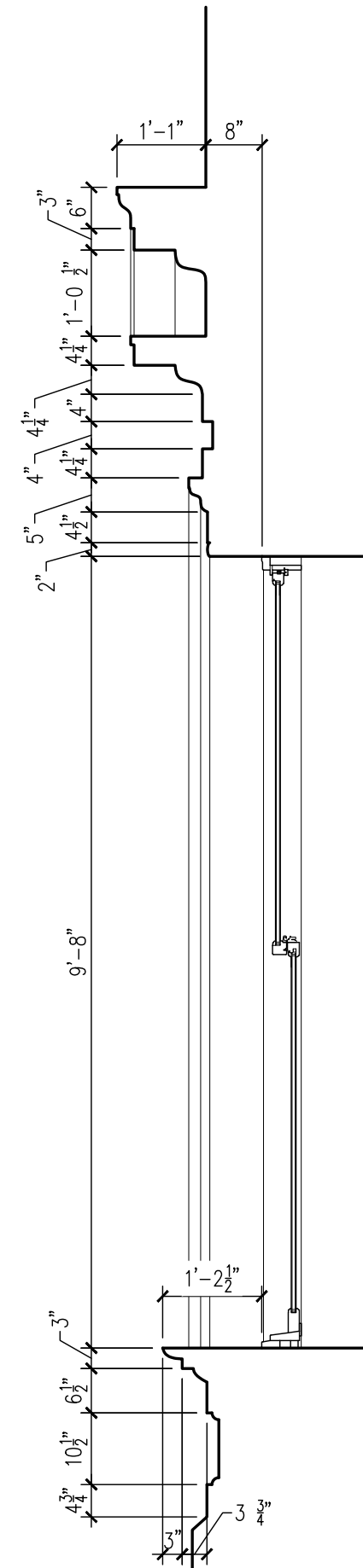

TYPICAL SECOND FLOOR PROFILE

SCALE: 1/2"=1'-0"

2

40 PLEASANT STREET
40 PLEASANT STREET
PORTSMOUTH, NH 03801

PROJECT:

KEY:

**WINTER
HOLBEN**
architecture + design

7 WALLINGFORD SQ
UNIT 209-9
KITTERY, MAINE 03904
207.994.3104

REVISIONS:

PROJECT NAME:
40 PLEASANT STREET
40 PLEASANT ST.
PORTSMOUTH, NH 03801

PROJECT NO.: 22065
DRAWN BY: GL/RW
APPROVED BY: BH
ISSUE DATE: 7/21/2022

DRAWING NAME:
SECOND FLOOR
WINDOW DETAIL

SCALE:

DRAWING NO.:

A5.1

2
A5.2

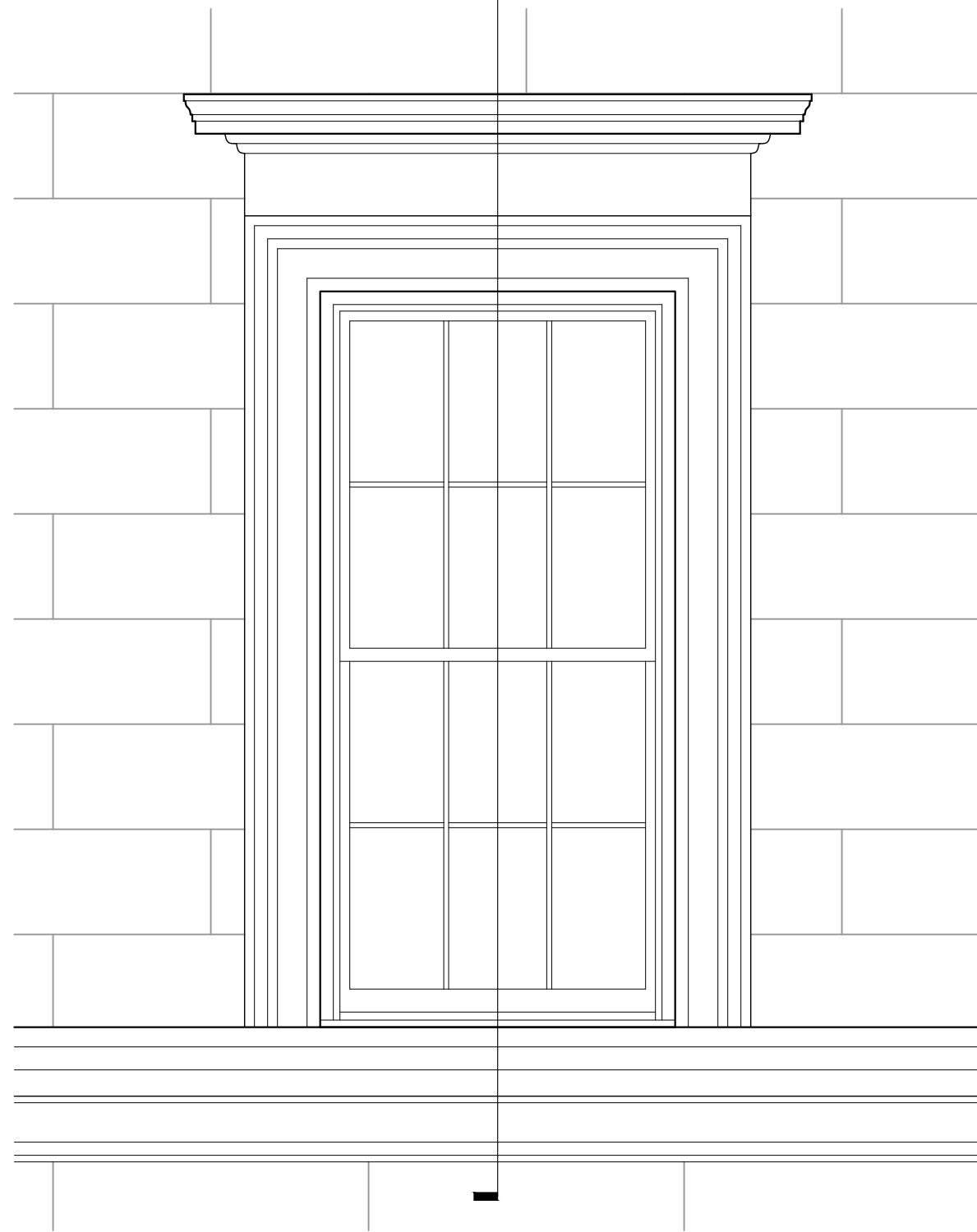

TYPICAL THIRD FLOOR WINDOW ELEV.

SCALE: 1/2"=1'-0"

A5.2 1

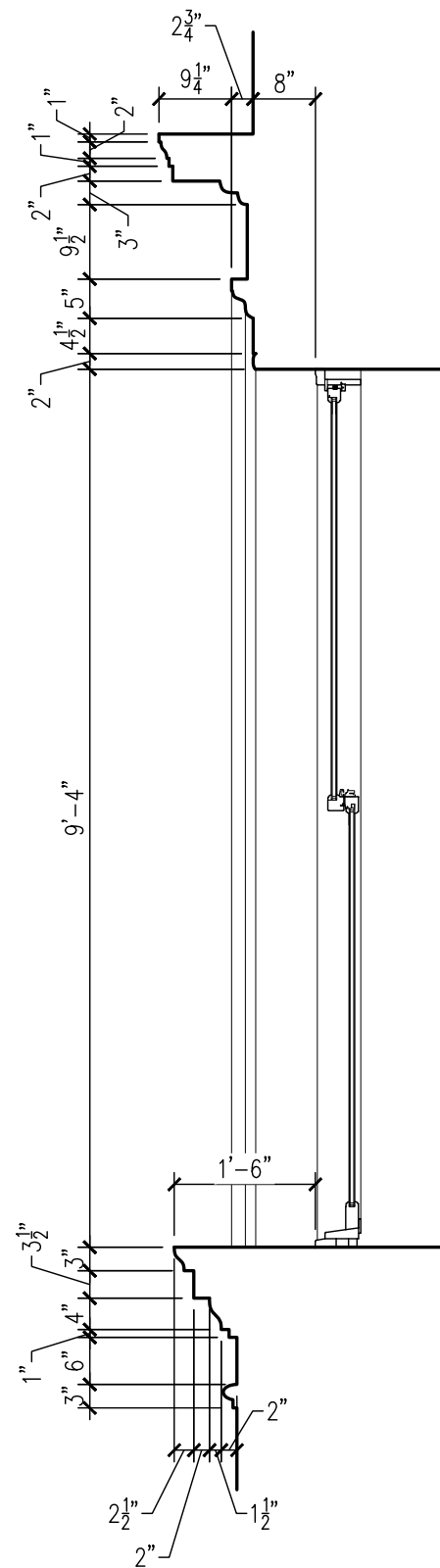

TYPICAL THIRD FLOOR PROFILE

SCALE: 1/2"=1'-0"

A5.2 2

40 PLEASANT STREET
40 PLEASANT STREET
PORTSMOUTH, NH 03801

PROJECT:
KEY:

**WINTER
HOLBEN**
architecture + design

7 WALLINGFORD SQ
UNIT 209-9
KITTERY, MAINE 03904
207.994.3104

REVISIONS:

PROJECT NAME:
40 PLEASANT STREET
40 PLEASANT ST.
PORTSMOUTH, NH 03801
PROJECT NO.: 22065
DRAWN BY: GL/RW
APPROVED BY: BH
ISSUE DATE: 7/21/2022
DRAWING NAME:

THIRD FLOOR
WINDOW DETAIL

SCALE:
DRAWING NO.:

A5.2

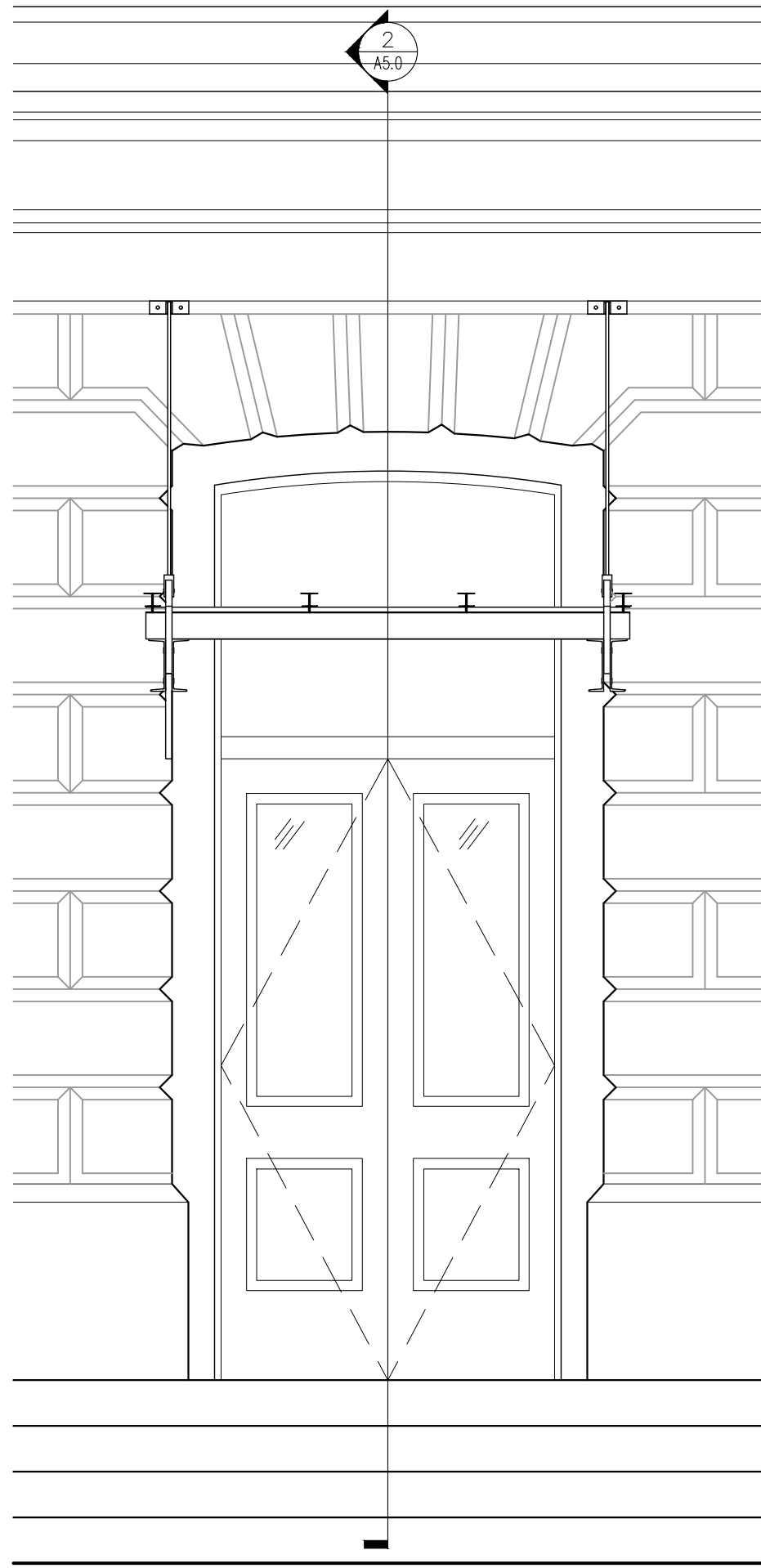

TYPICAL CANOPY ELEV.
SCALE: 1/2"=1'-0"

A5.3 1

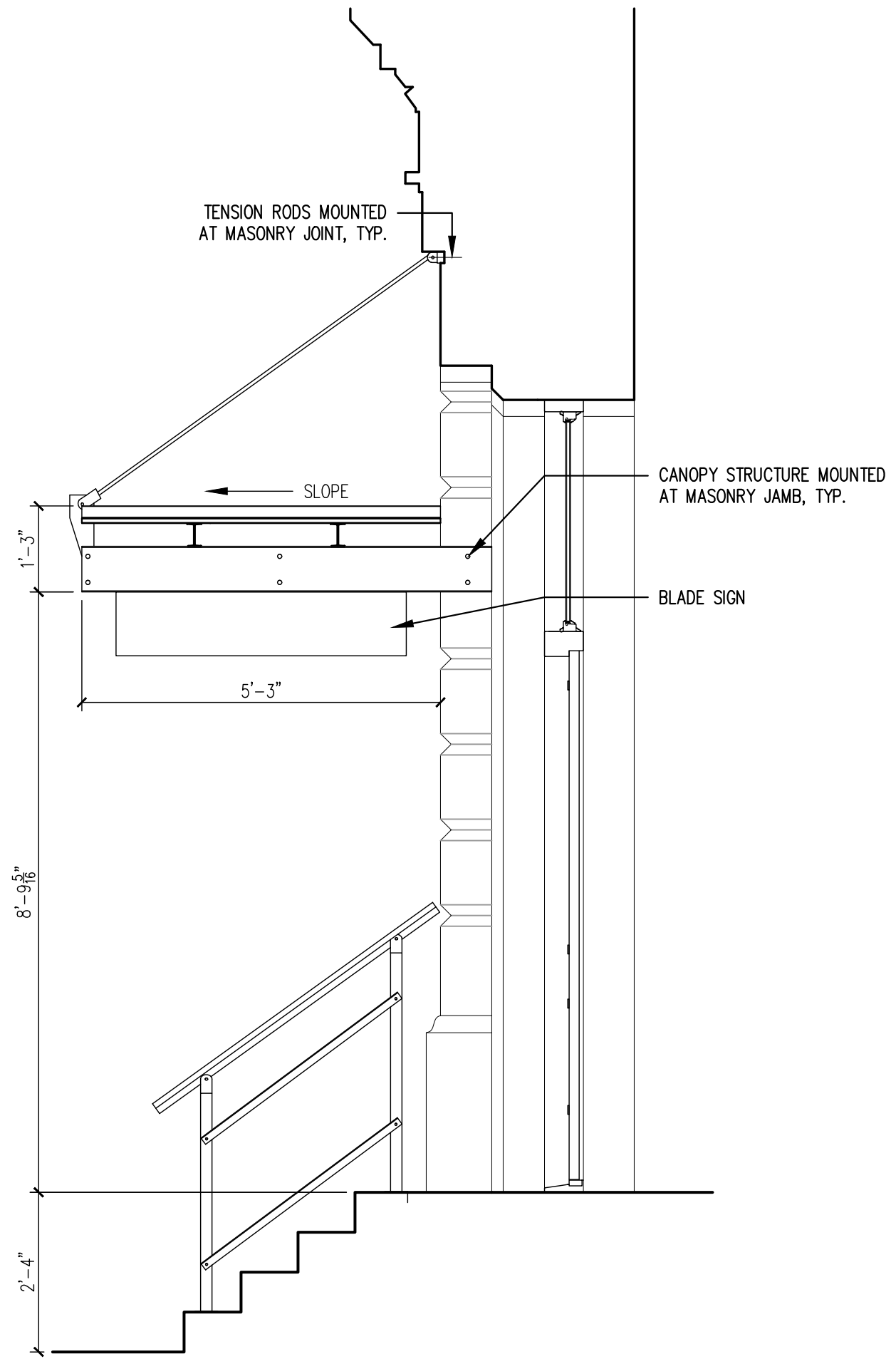

TYPICAL CANOPY PROFILE
SCALE: 1/2"=1'-0"

A5.3 2

40 PLEASANT STREET
40 PLEASANT STREET
PORTSMOUTH, NH 03801

PROJECT:
KEY:

**WINTER
HOLBEN**
architecture + design

7 WALLINGFORD SQ
UNIT 209-9
KITTERY, MAINE 03904
207.994.3104

REVISIONS:

PROJECT NAME:
40 PLEASANT STREET
40 PLEASANT ST.
PORTSMOUTH, NH 03801
PROJECT NO.: 22065
DRAWN BY: GL/RW
APPROVED BY: BH
ISSUE DATE: 7/21/2022

DRAWING NAME:
FIRST FLOOR
CANOPY DETAIL

SCALE:
DRAWING NO.:

A5.3



CANOPY CLOSEUP



SOUTHEAST AERIAL



PLEASANT STREET ELEVATION

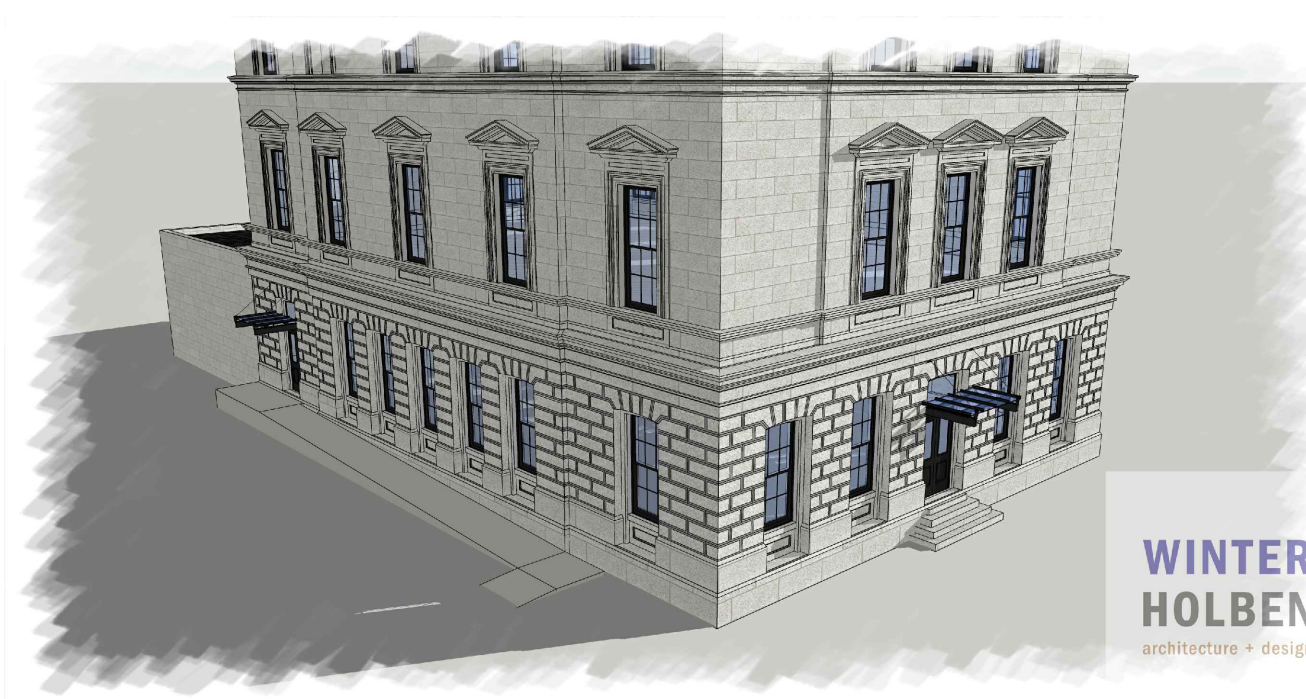

SOUTHWEST AERIAL

40 PLEASANT STREET
 40 PLEASANT STREET
 PORTSMOUTH, NH 03801

PROJECT:

KEY:

**WINTER
 HOLBEN**
 architecture + design

7 WALLINGFORD SQ
 UNIT 209-9
 KITTERY, MAINE 03904
 207.994.3104

REVISIONS:

PROJECT NAME:
 40 PLEASANT STREET
 40 PLEASANT ST.
 PORTSMOUTH, NH 03801
 PROJECT NO.: 22065
 DRAWN BY: GL/RW
 APPROVED BY: BH
 ISSUE DATE: 7/21/2022
 DRAWING NAME:

PERSPECTIVE
 IMAGES

SCALE:

DRAWING NO.:

A6.0

PROJECT:
 KEY:

**WINTER
 HOLBEN**
 architecture + design

7 WALLINGFORD SQ
 UNIT 209-9
 KITTERY, MAINE 03904
 207.994.3104

REVISIONS:

PROJECT NAME:
 40 PLEASANT STREET
 40 PLEASANT ST.
 PORTSMOUTH, NH 03801
 PROJECT NO.: 22065
 DRAWN BY: GL/RW
 APPROVED BY: BH
 ISSUE DATE: 7/21/2022
 DRAWING NAME:

WINDOW TYPES

SCALE:
 DRAWING NO.:

A7.0

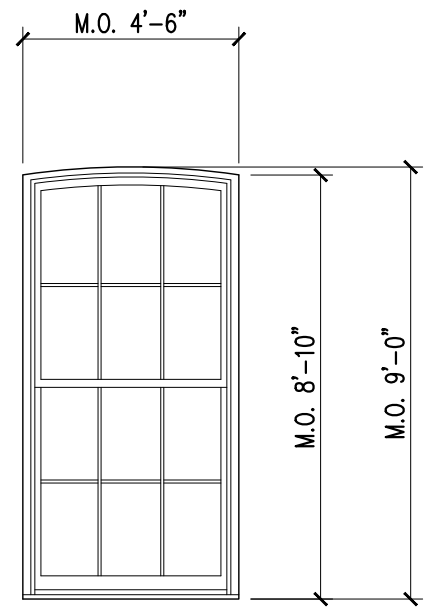

A

PELLA RESERVE TRADITIONAL
 SINGLE HUNG
 ALUMINUM CLAD WOOD

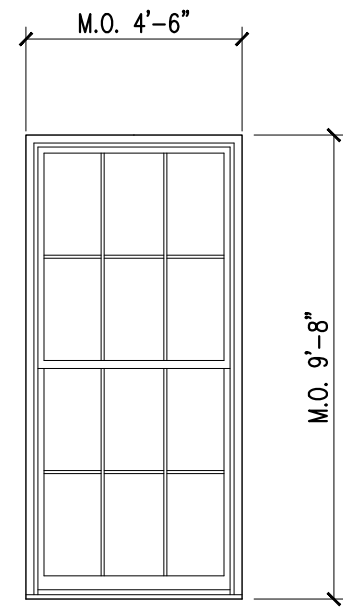

B

PELLA RESERVE TRADITIONAL
 SINGLE HUNG
 ALUMINUM CLAD WOOD

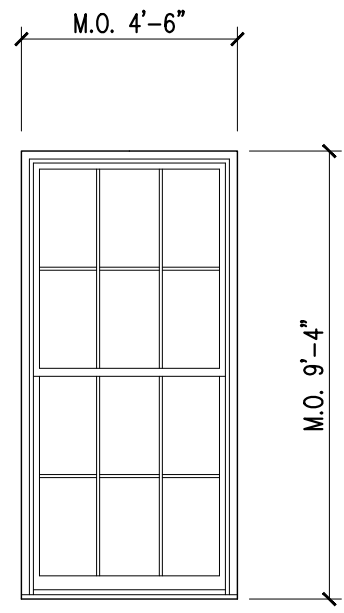

C

PELLA RESERVE TRADITIONAL
 SINGLE HUNG
 ALUMINUM CLAD WOOD

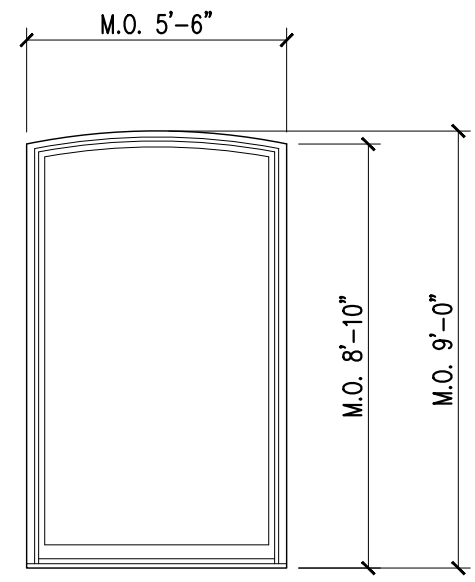

D

PELLA RESERVE TRADITIONAL
 FIXED STOREFRONT
 ALUMINUM CLAD WOOD

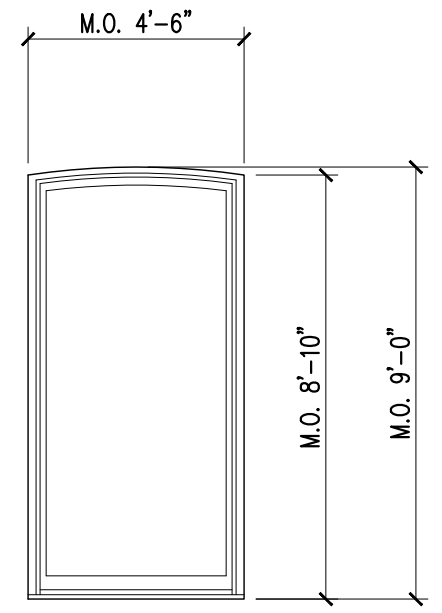

E

PELLA RESERVE TRADITIONAL
 FIXED STOREFRONT
 ALUMINUM CLAD WOOD

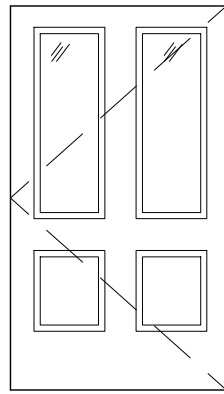

TYPE A

EXTERIOR WOOD

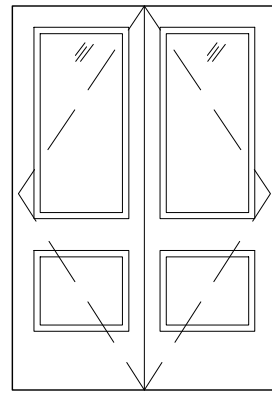

TYPE B

EXTERIOR WOOD
HINGED DOUBLE

NOTES:

CONTRACTOR TO VERIFY DOOR OPERATIONS WITH PLANS PRIOR TO ORDERING.

CONTRACTOR SHALL VERIFY SIZES, MODEL #'S, REQUIRED ROUGH OPENINGS, ETC. PRIOR TO PLACING THE DOOR ORDER.

DOOR SCHEDULE

NO.	ROOM NAME	DOOR		SIZE	FRAME MATERIAL	HRDWR	NOTES
		TYPE	MATERIAL				
100	FIRST FLOOR - MAIN ENTRY	B	WD/GLS	5'-6" X 8'-0"	WD	1	
101	FIRST FLOOR - RESIDENTIAL ENTRY	A	WD/GLS	4'-6" X 8'-0"	WD	1	
102	FIRST FLOOR - FIRE STAIR	A	WD/GLS	4'-6" X 8'-0"	WD	1	
103	FIRST FLOOR - BOOK & BAR	B	WD/GLS	5'-6" X 8'-0"	WD	1	
104	FIRST FLOOR - RAMP ENTRY	A	WD	4'-6" X 8'-0"	WD	1	
105	FIRST FLOOR - THAI BISTRO	A	WD/GLS	3'-0" X 7'-0"	WD	1	

DOOR TYPES
SCALE: 1/4"=1'-0"

A7.1 1

40 PLEASANT STREET
40 PLEASANT STREET
PORTSMOUTH, NH 03801

PROJECT:
KEY:

**WINTER
HOLBEN**
architecture + design

7 WALLINGFORD SQ
UNIT 209-9
KITTERY, MAINE 03904
207.994.3104

REVISIONS:

PROJECT NAME:
40 PLEASANT STREET
40 PLEASANT ST.
PORTSMOUTH, NH 03801
PROJECT NO.: 22065
DRAWN BY: GL/RW
APPROVED BY: BH
ISSUE DATE: 7/21/2022
DRAWING NAME:

DOOR TYPES

SCALE:
DRAWING NO.:

A7.1



Pella® Reserve™ Traditional Hung Window

Unit Sections - Aluminum-Clad Putty Glaze Exterior Profile

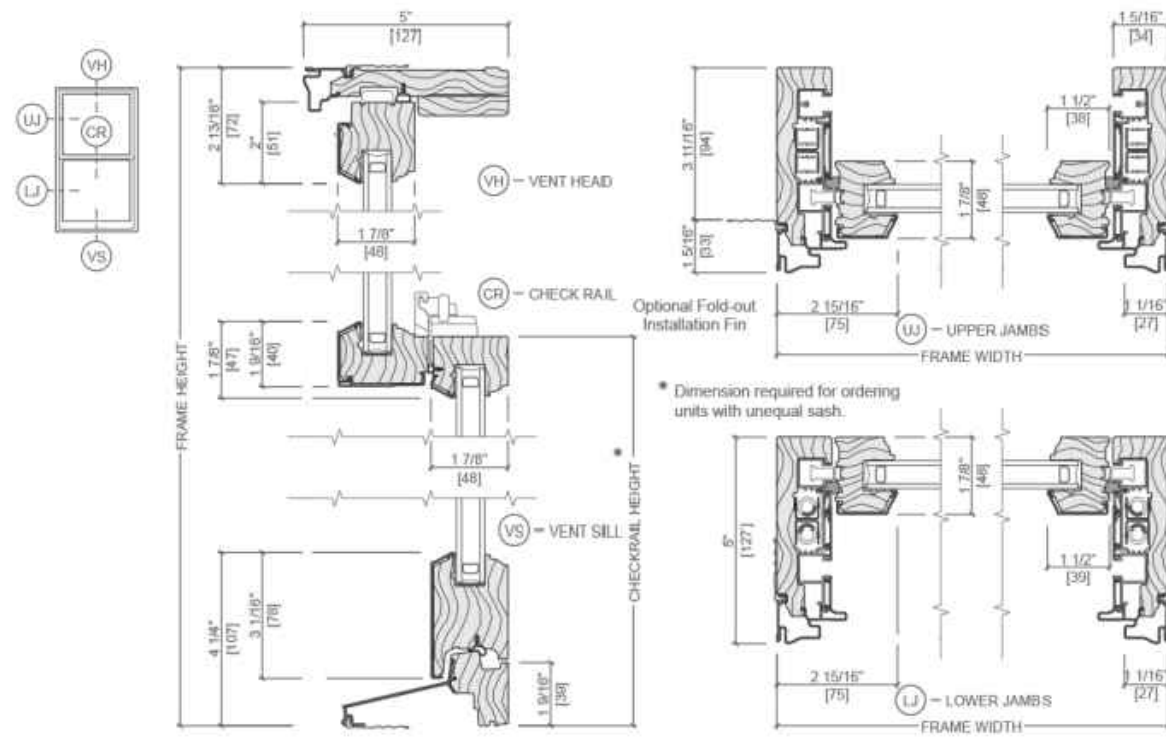

HISTORIC ELEMENTS

Exquisitely designed, traditional Pella Reserve windows deliver unparalleled historical detailing and have even been reviewed and approved on a case-by-case basis by the National Park Service for use on projects with historic tax credits. Featuring through-stile construction, deliberate proportions and intricate profiles to achieve authentic traditional style.

- [Putty Profile](#)
- [Through-Stile Construction](#)
- [Integral Light Technology](#)
- [Authentic Hardware](#)



40 PLEASANT STREET
 40 PLEASANT STREET
 PORTSMOUTH, NH 03801

PROJECT:

KEY:

**WINTER
 HOLBEN**

architecture + design

7 WALLINGFORD SQ
 UNIT 209-9
 KITTERY, MAINE 03904
 207.994.3104

REVISIONS:

PROJECT NAME:

40 PLEASANT STREET
 40 PLEASANT ST.
 PORTSMOUTH, NH 03801

PROJECT NO.: 22065

DRAWN BY: GL/RW

APPROVED BY: BH

ISSUE DATE: 7/21/2022

DRAWING NAME:

WINDOW CUT
 SHEET

SCALE:

DRAWING NO.:

A8.0

Specification Sheet

lumenbeam

Large
LBL

DYNAMIC WHITE

Project Name _____ Qty _____

Type _____ Catalog / Part Number _____



Front view

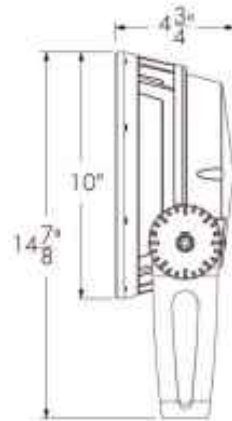

Side view

Photometric Summary

Symmetric

	Delivered output (lm)	Intensity (peak cd)
VN (6°)	2,841	148,030
NS (10°)	3,041	107,839
NF (20°)	3,005	28,185
M (30°)	2,754	12,450
FL (40°)	2,587	6,385
WFL (60°)	2,151	2,233

Asymmetric

NAS	3,161	48,684 (@2.5°)
WW	2,616	11,627 (@5°)

Based on DWH full output, DMX/RDM configuration.
Photometric performance is measured in compliance with IESNA LM-79-08.

Optics



VN 6° NS 10° NF 20° M 30°



FL 40° WFL 60° NAS WW

Colors and Color Temperatures



Controls

DIM/DTW DMX/RDM1 DMX/RDM
lumen talk DALI8

Description

The Lumenbeam Large Dynamic White is an IP66-rated luminaire for lighting landscapes, trees, columns, monuments, and architectural details with a special feature that enables the selection of any color temperature from 2200K to 3000K or from 2700K to 6500K. This dynamic feature gives designers and their clients the freedom to alter the ambiance of a space in response to the time of day or the way a space is used. A number of other options are on offer: optics for flood or accent lighting, as well as accessories, spread lenses, and controls. The luminaire also has an anti-corrosion option for use in harsh, chemical, or coastal environments.

Features

Color and Color Temperature	Dynamic warm white (2200K to 3000K), Dynamic white (2700K to 6500K)
Optics (nominal distribution)	VN (6°), NS (10°), NF (20°), M (30°), FL (40°), WFL (60°), NAS (Narrow Asymmetric), WW (Asymmetric Wallwash)
Optical Option	Linear spread lens horizontal distribution, Linear spread lens vertical distribution
Options	Short Yoke, 3G ANSI C136.31-2010 Vibration Rating for bridge applications, Corrosion-resistant coating for hostile environments
Cable Color	Black, White
Power Consumption	50 W
Warranty	5-year limited warranty
Performance	
Maximum Delivered Output	3161 lm (DWH full output, NAS, DMX/RDM)
Maximum Delivered Intensity	148,030 cd at nadir (DWH full output, VN 6°, DMX/RDM)
Illuminance at Distance	Minimum 1 fc at 385 ft (DWH full output, VN 6°, DMX/RDM)
Lumen Maintenance	L70 120,000 hrs (Ta 25 °C)

40 PLEASANT STREET
40 PLEASANT STREET
PORTSMOUTH, NH 03801

PROJECT:

KEY:

**WINTER
HOLBEN**

architecture + design

7 WALLINGFORD SQ
UNIT 209-9
KITTERY, MAINE 03904
207.994.3104

REVISIONS:

PROJECT NAME:

40 PLEASANT STREET
40 PLEASANT ST.
PORTSMOUTH, NH 03801

PROJECT NO.: 22065

DRAWN BY: GL/RW

APPROVED BY: BH

ISSUE DATE: 7/21/2022

DRAWING NAME:

LIGHTING CUT
SHEET

SCALE:

DRAWING NO.:

A8.1

lumenpulse™

1220 Marie-Victoria Blvd., Longueuil, QC, J4G 2H9, CA
info@lumenpulse.com www.lumenpulse.com

1 United States 617.307.5700 | Canada 1.877.937.3003 | 514.937.3003 F 514.937.6289
www.lumenpulse.com/products/2480

LMPG Inc. reserves the right to make changes to this product at any time without prior notice and such modification shall be effective immediately.
2022.08.01 copyright © 2022 LMPG Inc.
EM - 821

1 / 14



CANOPY PRECEDENT 1



CANOPY PRECEDENT 2



CANOPY PRECEDENT 3

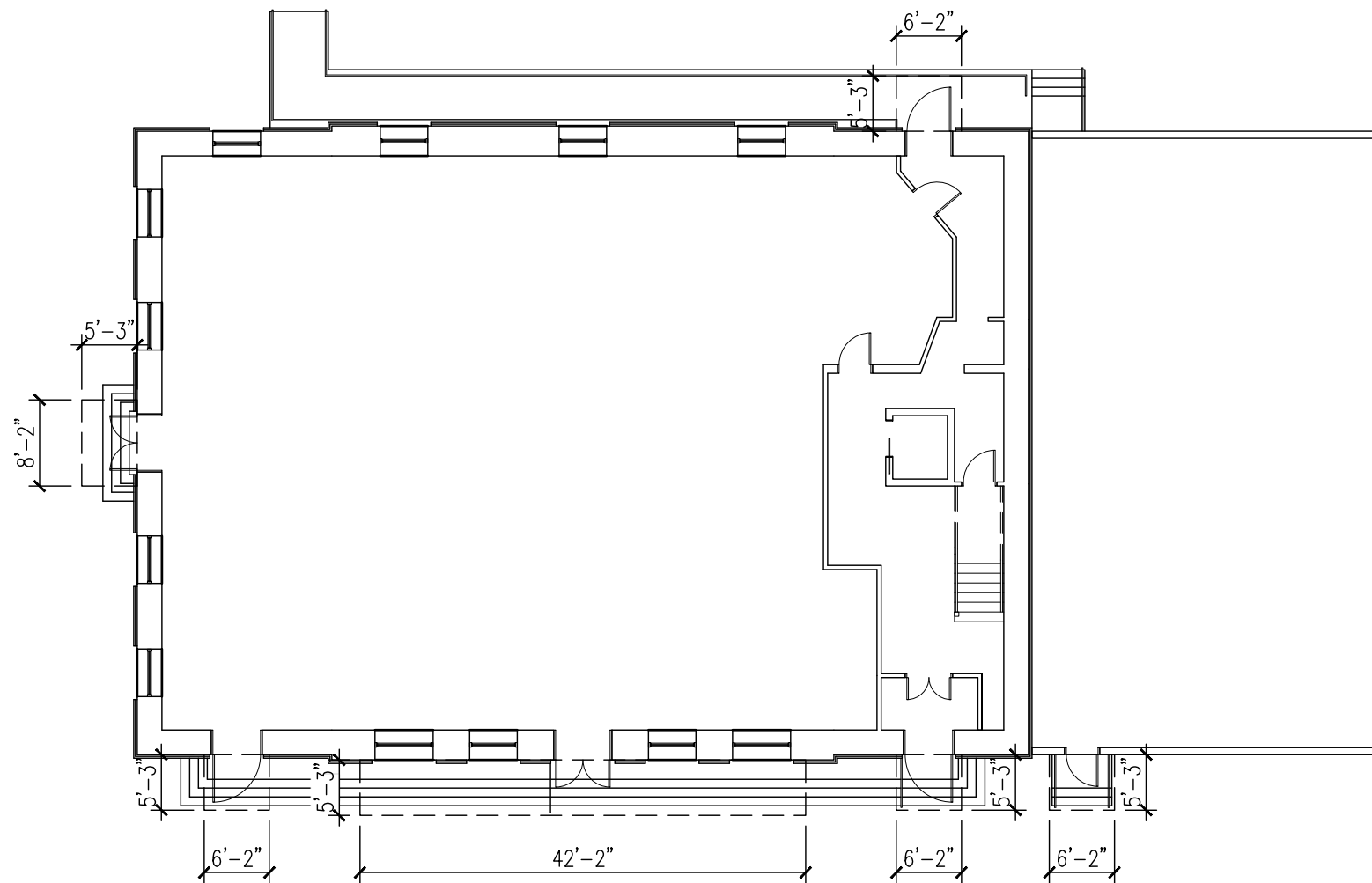

PROPOSED CANOPY PLAN
SCALE: 1/16"=1'-0"

1

40 PLEASANT STREET
40 PLEASANT STREET
PORTSMOUTH, NH 03801

PROJECT:

KEY:

**WINTER
HOLBEN**
architecture + design

7 WALLINGFORD SQ
UNIT 209-9
KITTERY, MAINE 03904
207.994.3104

REVISIONS:

PROJECT NAME:
40 PLEASANT STREET
40 PLEASANT ST.
PORTSMOUTH, NH 03801
PROJECT NO.: 22065
DRAWN BY: GL/RW
APPROVED BY: BH
ISSUE DATE: 7/21/2022

DRAWING NAME:
CANOPY PLAN
AND
INSPIRATION
IMAGES

SCALE:

DRAWING NO.:

A9.0



LIGHTING PRECEDENT 1



LIGHTING PRECEDENT 2



LIGHTING PRECEDENT 3



LIGHTING PRECEDENT 4

40 PLEASANT STREET
 40 PLEASANT STREET
 PORTSMOUTH, NH 03801

PROJECT:

KEY:

**WINTER
 HOLBEN**
 architecture + design

7 WALLINGFORD SQ
 UNIT 209-9
 KITTERY, MAINE 03904
 207.994.3104

REVISIONS:

PROJECT NAME:
 40 PLEASANT STREET
 40 PLEASANT ST.
 PORTSMOUTH, NH 03801
 PROJECT NO.: 22065
 DRAWN BY: GL/RW
 APPROVED BY: BH
 ISSUE DATE: 7/21/2022

DRAWING NAME:
 LIGHTING
 INSPIRATION
 IMAGES

SCALE:

DRAWING NO.:

A9.1