

CONTRACT DOCUMENTS AND SPECIFICATIONS

for

WOODBURY AVENUE TRAFFIC IMPROVEMENTS

City of Portsmouth Job #7131

Bid #02-09

State of New Hampshire

John P. Bohenko, City Manager

Prepared by:

City of Portsmouth
Engineering Division
Public Works Department

TABLE OF CONTENTS

INVITATION TO BID	3
INSTRUCTION TO BIDDERS	4
AWARD AND EXECUTION OF CONTRACT	7
PROPOSAL	9
BID BOND	14
BIDDER'S QUALIFICATIONS	16
CONTRACT AGREEMENT	20
NOTICE OF INTENT TO AWARD	23
NOTICE TO PROCEED	24
CHANGE ORDER	25
PERFORMANCE BOND	26
LABOR AND MATERIALS PAYMENT BOND	28
MAINTENANCE BOND	31
CONTRACTOR'S AFFIDAVIT	32
CONTRACTOR'S RELEASE	33
GENERAL REQUIREMENTS	34
CONTROL OF WORK	36
TEMPORARY FACILITIES	38
INSURANCE	39
MEASUREMENT AND PAYMENT	40
STANDARD SPECIFICATIONS	45
SHOP DRAWINGS	46
TECHNICAL SPECIFICATIONS	47

City of Portsmouth
Portsmouth, New Hampshire
Department of Public Works

Woodbury Avenue Traffic Improvements

INVITATION TO BID

Sealed bid proposals, **plainly marked, Woodbury Avenue Traffic Improvements**, Bid Proposal #02-09 **on the outside of the mailing envelope as well as the sealed bid envelope**, addressed to the Finance/Purchasing Department, City Hall, 1 Junkins Avenue, Portsmouth, New Hampshire, 03801, will be accepted until **August 6th, 2008 at 2:00pm**; at which time all bids will be publicly opened and read aloud.

This project consists of the installation of granite curbing, pavement resurfacing, lining & striping, drainage work, lawn restoration, traffic signal work and the installation of both paved and concrete sidewalks. Work may begin at any time on or after August 18th, 2008. All sections of the work shall be completed by November 26th, 2008. Liquidated damages shall be assessed at \$100.00 per day.

The Contractor will be required to keep roadways and sidewalks passable for the public to the maximum degree possible. The Contractor will also be responsible for ensuring that the public will be able to access the different businesses and residences at all times.

The General Contractor for this project must be Pre-qualified with NHDOT for Road Construction work. All electrical work on this project, including conduit, will be installed under the supervision of a New Hampshire Licensed Electrician. An electrical permit is required prior to any project work being completed.

Bidders must determine the quantities of work required and the conditions under which the work will be performed.

The City reserves the right, after bid opening and prior to award of the contract, to modify the amount of the work in the event that bids exceed budgeted amounts. The City of Portsmouth further reserves the right to reject any or all bids, to waive technical or legal deficiencies, to re-bid, and to accept any bid that it may deem to be in the best interest of the City. Also, the City reserves the right to approve or deny subcontractors for this project.

Each Bidder shall furnish a bid security in the amount of ten percent (10%) of the bid. The Bid Security may be in the form of a certified check or a bid bond executed by a surety company authorized to do business in the State of New Hampshire, made payable to the City of Portsmouth, N.H.

Questions may be directed to and specifications may be obtained from the Finance/Purchasing Department on the third floor at the above address, or by calling the Purchasing Coordinator at 603-610-7227. Specifications may also be obtained from the City's website www.cityofportsmouth.com.

INSTRUCTIONS TO BIDDERS

BIDDING REQUIREMENTS AND CONDITIONS

1. Special Notice to Bidders

Appended to these instructions is a complete set of bidding and general contract forms. These forms may be detached and executed for the submittal of bids. The plans, specifications, and other documents designated in the proposal form will be considered as part of the proposal, whether attached or not.

The bidders must submit a statement of bidder's qualifications, if requested, subsequent to bid opening but prior to award.

2. Interpretation of Quantities in Bid Schedules

The quantities appearing in the bid schedule are approximate only and are prepared for the comparison of bids. Payment to the contractor will be made only for actual work performed and accepted in accordance with the contract. Any scheduled item of work to be done and materials to be furnished may be increased, decreased or omitted as hereinafter provided, and no claim for loss, anticipated profits or costs incurred in anticipation of work not ultimately performed will be allowed due to such increase or decrease.

3. Examination of Plans, Specifications and Site Work

The bidder is expected to examine carefully the site of the proposed work, the plans, standard specifications, supplemental specifications, special provisions and contract forms before submitting a proposal. The submission of a bid shall be considered conclusive evidence that the bidder has made such examination and is satisfied as to the conditions to be encountered in performing the work and as to the requirements of the contract. It will be conclusive evidence that the bidder has also investigated and is satisfied with the sources of supply for all materials.

Plans, surveys, measurements, dimensions, calculations, estimates and statements as to the condition under which the work is to be performed are believed to be correct, but the contractors must examine for themselves, as no allowance will be made for any errors or inaccuracies that maybe found therein.

4. Familiarity with Laws

The bidder is assumed to have made himself or herself familiar with all federal and state laws and all local by-laws, ordinances and regulations which in any manner affect those engaged or employed on the work or affect the materials or equipment used in the work or affect the conduct of the work, and the bidder, if awarded the contract, shall be obligated to perform the work in conformity with said laws, by-laws, ordinances and regulations notwithstanding its ignorance thereof. If the bidder shall discover any provision in the plans or specifications which is in conflict with any such law, by-law, ordinance or regulation the bidder shall forthwith report it to the engineer in writing.

5. Preparation of Proposal

a) The bidder shall submit its proposal upon the forms furnished by the Owner. The bidder shall specify a lump sum price in figures, for each pay item for which a quantity is given and shall also show the products of the respective prices and quantities written in figures in the column provided for that purpose and the total amount of the proposal obtained by adding the amount of the several items. All words and figures shall be in ink or typed.

If a unit price or a lump sum bid already entered by the bidder on the proposal form is to be altered it should be crossed out with ink, the new unit price or lump sum bid entered above or below it and initialed by the bidder, also with ink.

b) The bidder's proposal must be signed with ink by the individual, by one or more general partners of a partnership, by one or more members or officers of each firm representing a joint venture; by one or more officers of a corporation, by one or more members (if member-managed) or managers (if manager-managed) of a limited liability company, or by an agent of the contractor legally qualified and acceptable to the owner. If the proposal is made by an individual, his or her name and post office address must be shown, by a partnership the name and post office address of each general and limited partner must be shown; as a joint venture, the name and post office address of each venturer must be shown; by a corporation, the name of the corporation and its business address must be shown, together with the name of the state in which it is incorporated, and the names, titles and business addresses of the president, secretary and treasurer.

6. Nonconforming Proposals

Proposals will be considered nonconforming and may be rejected in the Owner's sole discretion for any of the following reasons:

- If the proposal is on a form other than that furnished by the Owner, or if the form is altered or any portion thereof is detached;
- If there are unauthorized additions, conditional or altered bids, or irregularities of any kind which may tend to make the proposal or any portion thereof incomplete, indefinite or ambiguous as to its meaning;
- If the bidder adds any provisions reserving the right to accept or reject an award, or to enter into a contract pursuant to an award; or
- If the proposal does not contain a unit price for each pay item listed except in the case of authorized alter pay items.

7. Proposal Guaranty

No proposal will be considered unless accompanied by a bid bond, surety, or similar guaranty of the types and in an amount not less than the amount indicated in the Invitation to Bid. All sureties shall be made payable to the "City of Portsmouth". If a bid bond is used by the bidder it shall be:

- In a form satisfactory to the Owner;
- With a surety company licensed, authorized to do business in, and subject to the jurisdiction of the courts of the State of New Hampshire; and
- Conditioned upon the faithful performance by the principal of the agreements contained in the sub-bid or the general bid.

In the event any irregularities are contained in the proposal guaranty, the bidder will have four business days (not counting the day of opening) to correct any irregularities. The corrected guaranty must be received by 4:00 p.m. If irregularities are not corrected to the satisfaction of the Owner, the Owner, in its sole discretion, may reject the bid.

8. Delivery of Proposals

When sent by mail, the sealed proposal shall be addressed to the Owner at the address and in the care of the official in whose office the bids are to be received. All proposals shall be filed prior to the time and at the place specified in the invitation for bids. Proposals received after the time for opening of the bids will be returned to the bidder, unopened.

9. Withdrawal of Proposals

A bidder will be permitted to withdraw his or her proposal unopened after it has been submitted if the Owner receives a request for withdrawal in writing prior to the time specified for opening the proposals.

10. Public Opening of Proposals

Proposals will be opened and read publicly at the time and place indicated in the invitation for bids. Bidders, their authorized agents, and other interested parties are invited to be present.

11. Disqualification of Bidders

Any or all of the following reasons may be deemed by Owner in its sole discretion as being sufficient for the disqualification of a bidder and the rejection of his proposal:

- More than one proposal for the same work from an individual, firm, or corporation under the same or different name;
- Evidence of collusion among bidders;
- Failure to submit all required information requested in the bid specifications;
- If the Contractor is not listed with the New Hampshire Department of Transportation as a pre-qualified contractor under the classification of Road Construction;
- Lack of competency or of adequate machinery, plant or other equipment, as revealed by the statement of bidders qualification or otherwise;
- Uncompleted work which, in the judgment of the owner, might hinder or prevent the prompt completion of additional work if awarded;
- Failure to pay, or satisfactorily settle, all bills due for labor and materials on former contracts;
- Default or unsatisfactory performance on previous contracts; or
- Such disqualification would be in the best interests of the Owner.

12. Material Guaranty and Samples

Before any contract is awarded, the bidder may be required to furnish a complete statement of the origin, composition and manufacture of any or all materials to be used in the construction of the work, and the Owner may, in its sole discretion, reject the bid based on the contents of the statement or as a result of the failure of the bidder to submit the statement.

AWARD AND EXECUTION OF CONTRACT

1. Consideration of Proposals

After the proposals are opened and read, they will be compared on the basis of the total price for all sections of work and any such additional considerations as may be identified in the bid documents. The results of such comparisons will be immediately available to the public. In case of a discrepancy between the prices written in words and those written figures, the prices written in words shall govern. In case of a discrepancy between the total shown in the proposal and that obtained by adding the products of the quantities of items and unit bid prices, the latter shall govern.

2. Award of Contract

Within 30 calendar days after the opening of proposals, if a contract is to be awarded, the award will be made to the lowest responsible and qualified bidder whose proposal complies with all the requirements prescribed. The successful bidder will be notified, in writing, mailed to the address on his or her proposal, that his or her bid has been accepted and that the bidder has been awarded the contract.

3. Reservation of Rights

The Owner reserves the right to reject any or all proposals, to waive technicalities or to advertise for new proposals, if, in the sole discretion of the Owner, the best interest of the City of Portsmouth will be promoted thereby. The Owner further reserves the right to modify the scope of work in the event that bids exceed budgeted amounts.

The Owner reserves the right to cancel the award of any contract at any time before the execution of such contract by all parties without any liability of the Owner.

Without limiting the foregoing, award of this contract is contingent upon Owner obtaining prior to award all approvals necessary from impacted property owners.

4. Return of Proposal Guaranty

All proposal guaranties, except those of the three lowest bidders, will be returned upon request following the opening and checking of the proposals. The proposal guaranties of the three lowest bidders will be returned within ten days following the award of the contract if requested.

5. Contract Bonds

At the time of the execution of the contract, the successful bidder shall furnish:

- A performance bond in the amount of 100 percent of the contract amount.
- Labor and materials payment bond in the sum equal to 100 percent of the contract amount.

At the time of project completion, the Owner may, in its sole discretion, permit the Contractor to substitute a maintenance bond in lieu of holding retainage for the entire guaranty period. If a bond is furnished it shall meet the following criteria:

- The bond shall be in an amount equal to 20 percent of the contract amount. Such bond shall guarantee the repair of all damage due to faulty materials or workmanship provided or done by the contractor. The guarantee shall remain in effect for a period of one year after the date of final acceptance of the job by the Owner.

Each bond shall be: (1) in a form satisfactory to the Owner; (2) with a surety company licensed and authorized to do business and with a resident agent designated for services of process in the State of New Hampshire; and (3) conditioned upon the faithful performance by the principal of the agreements contained in the original bid. All premiums for the contract bonds are to be paid by the contractor.

6. Execution and Approval of Contract

The successful bidder is required to present all contract bonds, to provide proof of insurance, and to execute the contract within 10 days following receipt of the City's notification of acceptance of the bid. No contract shall be considered as in effect until it has been fully executed by all parties.

7. Failure to Execute Contract

Failure to execute the contract and file acceptable bonds within 10 days after notification of acceptance of bid shall be just cause for the cancellation of the award and the forfeiture of the proposal guarantee which shall become the property of the Owner, not as a penalty, but in liquidation of damages sustained. Award may then be made to the next lowest responsible bidder, or the City may exercise its reserved rights including the rejection of all bids or re-advertisement.

PROPOSAL FORM

Woodbury Avenue Traffic Improvements

CITY OF PORTSMOUTH, N.H.

To the City of Portsmouth, New Hampshire, herein called the Owner.

The undersigned, as Bidder, herein referred to as singular and masculine declares as follows:

1. All interested in the Bid as Principals are named herein.
2. This bid is not made jointly, or in conjunction, cooperation or collusion with any other person, firm, corporation, or other legal entity;
3. No officer, agent or employee of the Owner is directly or indirectly interested in this Bid.
4. The bidder has carefully examined the sites of the proposed work and fully informed and satisfied himself as to the conditions there existing, the character and requirements of the proposed work, the difficulties attendant upon its execution and the accuracy of all estimated quantities stated in this Bid, and the bidder has carefully read and examined the Drawings, Agreement, Specifications and other Contract Documents therein referred to and knows and understands the terms and provisions thereof;
5. The bidder understands that the quantities of work calculated in the Bid or indicated on the Drawings or in the Specifications or other Contract Documents are approximate and are subject to increase or decrease or deletion as deemed necessary by the Portsmouth City Engineer. Any such changes will not result in or be justification for any penalty or increase in contract prices; and agrees that, if the Bid is accepted the bidder will contract with the Owner, as provided in the Contract Documents, this Bid Form being part of said Contract Documents, and that the bidder will supply or perform all labor, services, plant, machinery, apparatus, appliances, tools, supplies and all other activities required by the Contract Documents in the manner and within the time therein set forth, and that the bidder will take in full payment therefore the following item prices, to wit:

PROPOSAL FORM (continued)

ITEM #	EST. QTY.	UNITS	ITEM DESCRIPTION & UNIT PRICE IN WORDS	UNIT PRICE IN FIGURES	ITEM TOTAL IN FIGURES
203.1	20	Cy	Common Excavation (where road widens)	\$ _____	\$ _____
203.2	460	Cy	Concrete Roadbed Excavation & Removal (Roadbed is between 8-10" and is steel reinforced) (Item includes any asphalt on top of the roadbed)	\$ _____	\$ _____
203.2A	5770	Sy	Existing Sidewalk & Pavement Removal	\$ _____	\$ _____
206.2	14	Ea	Catch Basin Structure Removal	\$ _____	\$ _____
214	1031	Sy	Roadway Fine Grading	\$ _____	\$ _____
304.3	750	Cy	Crushed Gravel	\$ _____	\$ _____
403.11	2200	Tons	Machine Pave 1 1/2"	\$ _____	\$ _____
403.12	500	Tons	Hand Method Bituminous Paving	\$ _____	\$ _____
403.98	750	Tons	Machine Method Leveling Course	\$ _____	\$ _____
410.21	25890	Sy	Emulsified Tack Coat	\$ _____	\$ _____
415.116	10700	Sy	Pavement Reinforcing Fabric over remaining Concrete Roadbed	\$ _____	\$ _____

PROPOSAL FORM (continued)

ITEM #	EST. QTY.	UNITS	ITEM DESCRIPTION & UNIT PRICE IN WORDS	UNIT PRICE IN FIGURES	ITEM TOTAL IN FIGURES
417	24860	Sy	Cold Planing 2"	\$ _____	\$ _____
420	190	Sy	Modified Synthetic Raised Crosswalk	\$ _____	\$ _____
520	300	Cy	Class B Curb Backfill	\$ _____	\$ _____
604.0007	14	Ea	Polyethylene Liner for CB	\$ _____	\$ _____
604.12	14	Ea	New Catch Basins (Type B) (Includes Snorkel)	\$ _____	\$ _____
604.4	19	Ea	Reconstruct Catch Basin Frame and Cover including adjusting for new grades	\$ _____	\$ _____
604.5	26	Ea	Reconstruct Manhole/Structure Frame and Cover including adjusting for new grades	\$ _____	\$ _____
604.5	20	Ea	Reconstruct Water Gate Valve Sleeve and Cover including adjusting for new grades	\$ _____	\$ _____
606.240	25	Lf	Corrosion Resistant Beam Guardrail	\$ _____	\$ _____
606.240	2	Ea	Corrosion Resistant Beam Guardrail End Sections	\$ _____	\$ _____
608.12	140	Ton	Bituminous Asphalt Sidewalk Overlays and Construct new Sidewalks	\$ _____	\$ _____

PROPOSAL FORM (continued)

ITEM #	EST. QTY.	UNITS	ITEM DESCRIPTION & UNIT PRICE IN WORDS	UNIT PRICE IN FIGURES	ITEM TOTAL IN FIGURES
608.24	12000	Sf	4" Concrete Sidewalk	\$ _____	\$ _____
608.24A	1050	Sf	4" Concrete Traffic Islands	\$ _____	\$ _____
608.26	700	Sf	6" Concrete Sidewalk in HC Ramp Areas	\$ _____	\$ _____
608.52	28	Ea	Detectable Warning Surface Panels Armor Tile, Color: Red	\$ _____	\$ _____
609.01	7420	Lf	New Straight Vertical Granite Curb 5" Wide	\$ _____	\$ _____
609.02	372	Lf	New Curved Vertical Granite Curb 5" Wide	\$ _____	\$ _____
609.21	380	Lf	New Straight Sloped Granite Curb	\$ _____	\$ _____
609.22	30	Lf	New Curved Sloped Granite Curb	\$ _____	\$ _____
609.5	1300	Lf	Reset Existing Curb	\$ _____	\$ _____
614	180	Lf	1 1/2" Schedule 80 PVC Conduit	\$ _____	\$ _____
615.02	289	Sf	Traffic Signs	\$ _____	\$ _____
615.02 A	1	U	Install Bike Route Traffic Signs	\$ _____	\$ _____

PROPOSAL FORM (continued)

ITEM #	EST. QTY.	UNITS	ITEM DESCRIPTION & UNIT PRICE IN WORDS	UNIT PRICE IN FIGURES	ITEM TOTAL IN FIGURES
616A	1	U	Traffic Signal upgrades at Granite St	\$ _____	\$ _____
616B	2	Ea	Radar School Speed Units	\$ _____	\$ _____
618.6	1000	Hr	Uniformed Portsmouth Police Flaggers <u>Forty Five thousand seven hundred fifty</u>	<u>\$45.75</u>	<u>\$45,750.00</u>
619.1	1	Unit	Maintenance of Traffic	\$ _____	\$ _____
621.31	10	Ea	Roadside Delineator with Post	\$ _____	\$ _____
628	11000	Lf	Saw Cut Pavement and/or Concrete as required	\$ _____	\$ _____
632.0104	25600	Lf	4" Paint Line Chlorinated Rubber Retroreflective	\$ _____	\$ _____
632.3112	1400	Lf	12" Crosswalks (Thermoplastic) Retroreflective 12" Thermoplastic Line	\$ _____	\$ _____
632.3124	880	Lf	Retroreflective 24" Thermoplastic Line	\$ _____	\$ _____
632.32	190	Sf	Retroreflective Thermoplastic Symbols	\$ _____	\$ _____
641	440	Cy	Lawn Restoration Loam (Includes Seeding)	\$ _____	\$ _____
645.7	1	U	SWPPP	\$ _____	\$ _____

PROPOSAL FORM (continued)

ITEM #	EST. QTY.	UNITS	ITEM DESCRIPTION & UNIT PRICE IN WORDS	UNIT PRICE IN FIGURES	ITEM TOTAL IN FIGURES
645.71	10	Hr	Monitor SWPPP	\$ _____	\$ _____
652.56	6	Ea	London Plane Tree 2" Caliper	\$ _____	\$ _____
652.68	2	Ea	Pin Oak Tree 2" Caliper	\$ _____	\$ _____
670	4000	Sf	Pressure Wash, prime & Paint Route 95 Bridge Abutments	\$ _____	\$ _____
692	1	Unit	Mobilization	\$ _____	\$ _____
TOTAL				\$ _____	

The City reserves the right to delete any portion of the work in the event the total price for all work exceeds budgeted amounts.

To Bidder: It is the intention of this contract that the items listed above describe completely and thoroughly the entirety of the work as shown on the plans and as described in the specifications. All other items required to accomplish the above items are considered to be subsidiary work, unless shown as a pay item.

TOTAL FOR PROJECT AND BASIS OF AWARD

In Figures \$ _____

In Words \$ _____

The undersigned agrees that for extra work, if any, performed in accordance with the terms and provisions of the Contract Documents, the bidder will accept compensation as stipulated therein.

Date

Company

By: _____
Signature

Business Address

Title: _____

City, State, Zip Code

Telephone: _____

We certify that the Company is currently pre-qualified with the State of New Hampshire for Road Construction.

The Bidder has received and acknowledged Addenda No. _____ through _____.
All Bids are to be submitted on this form and in a sealed envelope, plainly marked on the outside with the Bidder's name and address and the Project name as it appears at the top of the Proposal Form.

BID SECURITY BOND

(This format provided for convenience, actual Bid Bond is acceptable in lieu of, if compatible.)

KNOW ALL MEN BY THESE PRESENTS, that we the undersigned

_____, as Principal, and

_____, as Surety, are hereby

held and firmly bound unto _____

IN THE SUM OF _____

as liquidated damages for payment of which, well and truly to be made we hereby jointly and severally bind ourselves, our heirs, executors, administrators, successors and assigns.

The condition of this obligation is such that whereas the Principal has submitted to the

_____ A CERTAIN Bid attached hereto and hereby made a part hereof to enter into a contract in writing, hereinafter referred to as the "AGREEMENT" and or "CONTRACT", for

NOW THEREFORE,

- (a) If said Bid shall be rejected or withdrawn as provided in the INFORMATION FOR BIDDERS attached hereto or, in the alternative,
- (b) If said Bid shall be accepted and the Principal shall duly execute and deliver the form of AGREEMENT attached hereto and shall furnish the specified bonds for the faithful performance of the AGREEMENT and/or CONTRACT and for the payment for labor and materials furnished for the performance of the AGREEMENT and or CONTRACT,

then this obligation shall be void , otherwise it shall remain in full force and effect; it being expressly understood and agreed that the liability of the Surety for any and all claims hereunder in no event shall exceed the amount of this obligation.

BID SECURITY BOND (continued)

The Surety, for value received, hereby agrees that the obligation of said surety and its bond shall be in no way impaired or affected by any extensions of the time within such BID may be accepted, and said Surety does hereby waive notice of any such extension.

IN WITNESS WHEREOF, the parties hereto have duly executed

this bond on the _____ day of _____, 20__.

(Name of Principal) L.S.

(SEAL)

BY _____

(Name of Surety)

BY _____

STATEMENT OF BIDDER'S QUALIFICATIONS

Supply with Bid

All questions must be answered and the data given must be clear and comprehensive. This statement must be notarized. Add separate sheets if necessary

1. Name of Bidder
2. Permanent Main Office Address
3. Form of Entity
4. When Organized
5. Where Organized
6. How many years have you been engaged in the contracting business under your present name; also state names and dates of previous firm names, if any.
7. Contracts on hand; (schedule these, showing gross amount of each contract and the approximate anticipated dates of completion).
8. General character of work performed by your company.
9. Have you ever failed to complete any work awarded to you? ____ (no) ____ (yes). If so, where and why?
10. Have you ever defaulted on a contract?
____ (no) ____ (yes). If so, where and why?
11. Have you ever failed to complete a project in the time allotment according to the Contract Documents?
____ (no) ____ (yes). If so, where and why?
12. List the most important contracts recently executed by your company, stating approximate cost for each, and the month and year completed.
13. List your major equipment available for this contract.
14. List your key personnel such as project superintendent and foremen available for this contract.

STATEMENT OF BIDDERS QUALIFICATIONS (continued)

- 15. List any subcontractors whom you would expect to use for the following (unless this work is to be done by your own organization).
 - a. Paving _____
 - b. Concrete Flatwork _____
 - c. Signal Installation _____
 - d. Curbing _____
 - e. Pavement Markings _____
 - f. Abutment Painting _____

- 16. With what banks do you do business?
 - a. Do you grant the Owner permission to contact this/these institutions?
 ____ (yes) ____ (no).

b. Latest Financial Statements, certified audited if available, prepared by an independent certified public accountant, may be requested by Owner. If requested, such statements must be provided within five (5) business days or the bid proposal will be rejected. Certified Audited Statement are preferred. Internal statements may be attached only if independent statements were not prepared.

Dated at _____ this _____ day of _____, 20__.

 Name of Bidder

BY _____

TITLE _____

State of _____

County of _____

_____ being duly sworn, deposes and

says that the bidder is _____ of _____
 (Name of Organization)

and answers to the foregoing questions and all statements contained therein are true and correct.

Sworn to before me this _____ day of _____, 20__.

 Notary of Public
 My Commission expires _____

CONTRACT AGREEMENT

Woodbury Avenue Traffic Improvements

THIS AGREEMENT made as of the _____ day of _____ in the year **2008**, by and between the City of Portsmouth, New Hampshire (hereinafter call the Owner) and _____ (hereinafter called the Contractor),

WITNESSETH; that the Owner and Contractor, in consideration of the mutual covenants hereinafter set forth, agree as follows:

ARTICLE I - Work - The Contractor shall perform all work as specified or indicated in the Contract Documents for the completion of the Project. The Contractor shall provide, at his expense, all labor, materials, equipment and incidentals as may be necessary for the expeditious and proper execution of the Project.

ARTICLE II - ENGINEER - The City Engineer, or his authorized representative will act as engineer in connection with completion of the Project in accordance with the Contract Documents.

ARTICLE III - CONTRACT TIME - The work will commence in accordance with the Notice to Proceed. **All work shall be completed no later than November 26, 2008.**

ARTICLE IV - CONTRACT PRICE - Owner shall pay Contractor for performance of the work in accordance with the Contract Documents as shown under item prices in the Bid Proposal.

ARTICLE V - PAYMENT - Partial payments will be made in accordance with the Contract Documents. Upon final acceptance of the work and settlement of all claims, Owner shall pay the Contractor the unpaid balance of the Contract Price, subject to additions and deductions provided for in the Contract Documents.

ARTICLE VI - RETAINAGE – To insure the proper performance of this Contract, the Owner shall retain **ten percent** of the Contract Price as specified in the Contract Documents.

ARTICLE VII - LIQUIDATED DAMAGES - In event the Contractor fails to successfully execute the work within the specified contract time the Owner shall assess the Contractor liquidated damages in the amount of **one hundred dollars (\$100)** for each calendar day beyond the specified completion date for each section of work. Liquidated damages shall be deducted from the Contract Price prior to final payment of the Contractor.

CONTRACT AGREEMENT (continued)

ARTICLE VIII – CONTRACT DOCUMENTS – The Contract Documents which comprise the contract between Owner and Contractor are attached hereto and made a part hereof and consist of the following:

- 8.1 This Agreement
- 8.2 Contractor’s Bid and Bonds
- 8.3 Notice of Award, Notice to Proceed
- 8.4 Instruction to Bidders
- 8.5 General Requirements, Control of Work, Temporary Facilities, Measurement and Payment, Standard Specifications
- 8.6 Insurance Requirements
- 8.7 Standard and Technical Specifications
- 8.8 Drawings
- 8.9 Special Provisions
- 8.10 Any modifications, including change orders, duly delivered after execution of this Agreement.

ARTICLE IX – TERMINATION FOR DEFAULT – Should contractor at any time refuse, neglect, or otherwise fail to supply a sufficient number or amount of properly skilled workers, materials, or equipment, or fail in any respect to prosecute the work with promptness and diligence, or fail to perform any of its obligations set forth in the Contract, Owner may, at its election, terminate the employment of Contractor, giving notice to Contractor in writing of such election, and enter on the premises and take possession, for the purpose of completing the work included under this Agreement, of all the materials, tools and appliances belonging to Contractor, and to employ any other persons to finish the work and to provide the materials therefore at the expense of the Contractor.

ARTICLE X – INDEMNIFICATION OF OWNER – Contractor will indemnify Owner against all suits, claims, judgments, awards, loss, cost or expense (including without limitation attorneys’ fees) arising in any way out of the Contractor’s negligent performance of its obligations under this Contract. Contractor will defend all such actions with counsel satisfactory to Owner at its own expense, including attorney’s fees, and will satisfy any judgment rendered against Owner in such action. Contractor will also indemnify KSC LLC in the same manner as Owner for any work related to the pay item for 141 Congress Street.

ARTICLE XI – PERMITS – The Contractor will secure at its own expense, all permits and consents required by law as necessary to perform the work and will give all notices and pay all fees and otherwise comply with all applicable City, State, and Federal laws, ordinances, rules and regulations.

ARTICLE XII – INSURANCE – The Contractor shall secure and maintain, until acceptance of the work, insurance with limits not less than those specified in the Contract.

ARTICLE XIII – MISCELLANEOUS –

- A. Neither Owner nor Contractor shall, without the prior written consent of the other, assign, sublet or delegate, in whole or in part, any of its rights or obligations under any of the Contract Documents; and, specifically not assign any monies due, or to become due, without the prior written consent of Owner.
- B. Owner and Contractor each binds himself, his partners, successors, assigns and legal representatives, to the other party hereto in respect to all covenants, agreements and obligations contained in the Contract Documents.
- C. The Contract Documents constitute the entire Agreement between Owner and Contractor and may only be altered amended or repealed by a duly executed written instrument.
- D. The laws of the State of New Hampshire shall govern this Contract without reference to the conflict of law principles thereof.
- E. Venue for any dispute shall be the Rockingham County Superior Court unless the parties otherwise agree.

IN WITNESS WHEREOF, the parties hereunto executed this
AGREEMENT the day and year first above written.

BIDDER:

BY: _____

TITLE: _____

CITY OF PORTSMOUTH, N.H.

BY: _____
John P. Bohenko

TITLE: City Manager

NOTICE OF INTENT TO AWARD

Date:

TO:

IN AS MUCH as you were the low responsible bidder for work entitled:

Woodbury Avenue Traffic Improvements

You are hereby notified that the City intends to award the aforesaid project to you.

Immediately take the necessary steps to execute the Contract and to provide required bonds and proof of insurance within ten (10) calendar days from the date of this Notice.

The City reserves the right to revoke this Notice if you fail to take the necessary steps to execute this Contract.

City of Portsmouth
Portsmouth, New Hampshire

Judie Belanger,
Finance Director

NOTICE TO PROCEED

DATE:

Woodbury Avenue Traffic Improvements

TO:

YOU ARE HEREBY NOTIFIED TO COMMENCE WORK IN ACCORDANCE
WITH THE AGREEMENT DATED _____, ON OR
AFTER August 18, 2008 AND ALL WORK SHALL BE COMPLETED BY November 26, 2008.

CITY OF PORTSMOUTH, N.H.

BY: Steven F. Parkinson, PE

TITLE: Public Works Director

ACCEPTANCE OF NOTICE

RECEIPT OF THE ABOVE NOTICE TO
PROCEED IS HEREBY ACKNOWLEDGED BY

This the ____ day of _____ 20__

By: _____

Title: _____

CHANGE ORDER

Change Order Number _____ Date of Issuance _____

Owner: CITY OF PORTSMOUTH, N.H

Contractor:

You are directed to make the following changes in the
Contract Documents:

Description:

Purpose of Change Order:

Attachments:

CHANGE IN CONTRACT PRICE

CHANGE IN CONTRACT TIME

Original Contract Price:
\$ _____

Original Completion Date:

Contract Price prior to this
Change Order:
\$ _____

Contract Time prior to this
Change Order:
_____ days

Net Increase or Decrease of
this Change Order:
\$ _____

Net Increase or Decrease of
this Change Order:
_____ days

Contract Price with all
approved Change Orders:
\$ _____

Contract Time with all
approved Change Orders:
_____ days

RECOMMENDED:

APPROVED:

APPROVED:

by _____

by _____

by _____

by _____

PW Director

City Finance

City Manager

Contractor

PERFORMANCE BOND

(This format provided for convenience, actual Performance Bond is acceptable in lieu, if compatible)

Bond Number _____

KNOW ALL MEN BY THESE PRESENTS

that _____ as Principal, hereinafter called Contractor, and _____ (Surety Company) a corporation organized and existing under the laws of the State of _____ and authorized to do business in the State of New Hampshire as surety, hereinafter called Surety, are held and firmly bound unto the City of Portsmouth, N.H. Obligee, hereinafter called Owner, in the amount of _____ Dollars (\$_____), for the payment whereof Contractor and Surety bind themselves, their heirs, executors, administrators, successors and assigns, jointly and severally, firmly by these presents. WHEREAS, Contractor has by written agreement dated _____ entered into a contract with Owner for _____ in accordance with drawings and specifications prepared by the Public Works Department, 680 Peaverly Hill Road, Portsmouth, N.H. 03801, which contract is by reference made a part hereof, and is hereinafter referred to as the Contract.

NOW, THEREFORE, THE CONDITION OF THIS OBLIGATION is such that if the Contractor shall well and faithfully do and perform the things agreed by him to be done and performed, according to the terms of said Contract and such alterations as may be made in said Contract during progress work, and shall further indemnify and save harmless the said Owner in accordance with the Contract and shall remedy without cost to the Owner any defect which may develop within one year from the time of completion and acceptance of the work.

The Surety hereby waives notice of any alteration in work or extension of time made by the Owner or any of its agents or representatives.

Whenever Contractor shall be, and declared by Owner to be, in default under the Contract, the Owner having performed Owner's obligations thereunder, the Surety may promptly remedy the default, or shall promptly:

- (1) Complete the Contract in accordance with its terms and conditions, or

PERFORMANCE BOND (continued)

(2) Obtain a bid or bids for submission to the Owner for completing the Contract in accordance with its terms and conditions, and upon determination by Owner and Surety of the lowest responsible bidder, arrange for a contract between such bidder and Owner and make available as work progresses (even though there should be a default or a succession of defaults under the contract of completion arranged under this paragraph) sufficient funds to pay the cost of completion less the balance of the contract price; but not exceeding, including other costs and damages for which the Surety may be liable hereunder, the amount set forth in the first paragraph hereof. The term "balance of the contract price", as used in this paragraph, shall mean the total amount payable by the Owner to Contractor under the Contract and any amendments thereto, less the amount paid by Owner to Contractor.

Any suit under this bond must be instituted before the expiration of (2) years from the date on which final payment under the contract falls due.

No right of action shall accrue on this bond to or for the use of any person or corporation other than the Owner named herein or the heirs, executors, administrators or successors of Owner.

Signed and sealed this _____ day of _____

A.D., 20___ .

In the presence of:

_____	BY: _____
(Witness)	(Principal) (Seal)

(Surety Company)

_____	BY: _____
(Witness)	(Title) (Seal)

Note:

If the Principal (Contractor) is a partnership, the Bond should be signed by each of the partners.

If the Principal (Contractor) is a corporation, the Bond should be signed in its correct corporate name by its duly authorized Officer or Officers.

If this bond is signed on behalf of the Surety by an attorney-in-fact, there should be attached to it a duly certified copy of his Power of Attorney showing his authority to sign such Bonds.

There should be executed an appropriate number of counterparts of the bond corresponding to the number of counterparts of the Agreement.

LABOR AND MATERIAL PAYMENT BOND

(This format provided for convenience, actual Labor and Material Bond is acceptable in lieu, if compatible)

Bond Number _____

KNOW ALL MEN BY THESE PRESENTS:

that _____

as Principal, hereinafter called Contractor, and _____ (Surety Company) a corporation organized and existing under the laws of the State of

_____ and authorized to do business in the State of New Hampshire hereinafter called Surety, are held and firmly bound unto the City of Portsmouth, N.H. Obligee, hereinafter called Owner, for the use and benefit of claimants as herein below defined, in the

amount of _____ Dollars (\$ _____), for the payment whereof Principal and Surety bind themselves, their heirs, executors, administrators, successors and assigns, jointly and severally, firmly by these presents.

WHEREAS, Principal has by written agreement dated _____ entered into a

contract with Owner for _____ in accordance with drawings and specifications prepared by the Public Works Department, 680 Peverly Hill Road, Portsmouth, N.H. 03801, which contract is by reference made a part hereof, and is hereinafter referred to as the Contract.

NOW, THEREFORE, THE CONDITION OF THIS OBLIGATION is such that the Principal shall promptly make payment to all claimants as hereinafter defined, for all labor and material used or reasonably required for use in the performance of the Contract and for the hire of all equipment, tools, and all other things contracted for or used in connection therewith, then this obligation shall be void, otherwise it shall remain in full force and effect, subject however, to the following conditions:

(1) A claimant is defined as one having a direct contract with the Principal or, with a subcontractor of the Principal for labor, material, equipment, or other things used or reasonably required for use in the performance of the Contract. "Labor and material" shall include but not be limited to that part of water, gas, power, light, heat, oil and gasoline, telephone service or rental of equipment applicable to the Contract.

(2) The above named Principal and Surety hereby jointly and severally agree with the Owner that every claimant as herein defined, who has not been paid in full before the expiration of a period of ninety (90) days after the date on which the last of such claimant's work or labor was done or performed, or materials were furnished by such a claimant, may sue on this bond for the use of such claimant, prosecute the suit by final judgment for such sum or sums as may be

LABOR AND MATERIAL PAYMENT BOND (continued)

justly due claimant, and have execution thereon. The Owner shall not be liable for the payment of any such suit or any costs or expenses of any such suit, and principal and surety shall jointly and severally indemnify, defend and hold the Owner harmless for any such suit, costs or expenses.

(3) No suit or action shall be commenced hereunder by any claimant:

(a) Unless Claimant, other than one having a direct contract with the Principal, shall have given notice to all the following:

The Principal, the Owner and the Surety above named, within six (6) calendar months after such claimant did or performed the last of the work or labor, or furnished the last of the materials for which said claim is made, stating with substantial accuracy the amount claimed and the name of the party to whom the materials were furnished, or for whom the work or labor was done or performed. Such notice shall be served by mailing the same by registered mail or certified mail, postage prepaid, in an envelope addressed to the Principal, Owner, and Surety, at any place where an office is regularly maintained for the transaction of business, or served in any manner in which legal process may be served in the State of New Hampshire save that such service need not be made by a public officer.

(b) After the expiration of one (1) year following the date on which Principal ceased all work on said contract, it being understood, however, that if any limitation embodied in this bond is prohibited by any law controlling the construction hereof, such limitation shall be deemed to be amended so as to be equal to the minimum period of limitation permitted by such law.

(c) Other than in a State court of competent jurisdiction in and for the county or other political subdivision of the State in which the project, or any part thereof, is situated, or in the United States District Court for the district in which the project, or any part thereof, is situated, and not elsewhere. (4) The amount of this bond may be reduced by and to the extent of any payment of payments made in good faith hereunder, inclusive of the payment by Surety of mechanics' liens which may be filed on record against said improvement, whether or not claim for the amount of such lien by presented under and against this bond.

Signed and sealed this _____ day of _____, 20____. In the presence of:

(Witness) BY: _____
(Principal) (Seal)

(Surety Company)

(Witness) BY: _____
(Title) (Seal)

LABOR AND MATERIAL PAYMENT BOND (continued)

Note:

If the Principal (Contractor) is a partnership, the Bond should be signed by each of the partners.

If the Principal (Contractor) is a corporation, the Bond should be signed in its correct corporate name by its duly authorized Officer or Officers.

If this bond is signed on behalf of the Surety by an attorney-in-fact, there should be attached to it a duly certified copy of his Power of Attorney showing his authority to sign such Bonds.

There should be executed an appropriate number of counterparts of the bond corresponding to the number of counterparts of the Agreement.

MAINTENANCE BOND

At the Owner's election, a maintenance bond may be substituted for retainage at the completion of the project. If the Owner permits a maintenance bond, it shall be in the amount of **Twenty Percent (20%)** of the contract price with a corporate surety approved by the Owner. Such bond shall be provided at the time of Contract completion and shall guarantee the repair of all damage due to faulty materials or workmanship provided or done by the Contractor. This guarantee shall remain in effect for a period of one year after the date of final acceptance of the job by the Owner.

CONTRACTOR'S AFFIDAVIT

STATE OF _____:

COUNTY OF _____:

Before me, the undersigned, a _____
(Notary Public, Justice of the Peace)

in and for said County and State personally appeared, _____
(Individual, Partner, or duly authorized representative of Corporate)

who, being duly sworn, according to law deposes and says that the cost of labor, material, and equipment and outstanding claims and indebtedness of whatever nature arising out of the performance of the Contract between

CITY OF PORTSMOUTH, NEW HAMPSHIRE

and _____
(Contractor)

of _____

Dated: _____

has been paid in full for Construction of: **Woodbury Avenue Traffic Improvements**

(Individual, Partner, or
duly authorized
representative of
Corporate Contractor)

Sworn to and subscribed
before me this _____ day
of _____ 20__

CONTRACTOR'S RELEASE

KNOW ALL MEN BY THESE PRESENTS that _____

(Contractor) of _____, County of _____ and State of

_____ does hereby acknowledge

that _____ (Contractor)

has on this day had, and received from the CITY OF PORTSMOUTH NEW HAMPSHIRE, final and completed payment for the Construction of:

Woodbury Avenue Traffic Improvements

NOW THEREFORE, the said _____

(Contractor)

for myself, my heirs, executors, and administrators) (for itself, its successors and assigns) do/does by these presents remise, release, quit-claim and forever discharge the City of Portsmouth, New Hampshire, its successors and assigns, of and from all claims and demands arising from or in connection with the said Contract dated _____, and of and from all, and all manners of action and actions, cause and causes of action and actions, suits, debts, dues, duties, sum and sums of money, accounts, reckonings, bonds, bills, specifications, covenants, contracts, agreements, promises, variances, damages, judgments, extents, executions, claims and demand, whatsoever in law of equity, or otherwise, against the City of Portsmouth, New Hampshire, its successors and assigns, which (I, my heirs, executors, or administrators) (it, its successors and assigns) ever had, now have or which (I, my heirs, executors, or administrators) (it, its successors and assigns) hereafter can shall or may have, for, upon or by reason of any matter, cause, or thing whatsoever; from the beginning of record time to the date of these presents.

IN WITNESS WHEREOF,

Contractor:

print name of witness: _____

By: _____
Its Duly Authorized _____

Dated: _____

GENERAL REQUIREMENTS

SCOPE OF WORK

1. INTENT OF CONTRACT

The intent of the Contract is to provide for the construction and completion in every detail of the work described. The Contractor shall furnish all labor, materials, equipment, tools, transportation and supplies required to complete the work in accordance with the terms of the Contract. The Contractor shall be required to conform to the intent of the plans and specifications. No extra claims shall be allowed for portions of the work not specifically addressed in the plans and specifications but required to produce a whole and complete project, such work will be considered subsidiary to the bid items.

2. INCIDENTAL WORK

Incidental work items for which separate payment is not measured includes, but is not limited to, the following items:

- a. Clearing, grubbing and stripping (unless otherwise paid for)
- b. Clean up
- c. Plugging existing sewers and manholes
- d. Signs
- e. Mobilization/Demobilization (unless otherwise paid for)
- f. Restoration of property
- g. Cooperation with other contractors, abutters and utilities.
- h. Utility crossings, (unless otherwise paid for)
- i. Minor items - such as replacement of fences, guardrails, rock wall, etc.
- j. Steel and/or wood sheeting as required.
- k. Accessories and fasteners or components required to make items paid for under unit prices or lump sum items complete and functional.

3. ALTERATION OF PLANS OR OF CHARACTER OF WORK

The Owner reserves the right, without notice to Surety, to make such alterations of the plans or of the character of the work as may be necessary or desirable to complete fully and acceptably the proposed construction; provided that such alterations do not increase or decrease the contract cost. Within these cost limits, the alterations authorized in writing by the Owner shall not impair or affect any provisions of the Contract or bond and such increases or decreases of the quantities as a result from these alterations or deletions of certain items, shall not be the basis of claim for loss or for anticipated profits by the contractor. The contractor shall perform the work as altered at the contract unit price or prices.

4. EXTRA WORK ITEMS

Extra work shall be performed by the Contractor in accordance with the specifications and as directed, and will be paid for at a price as provided in the Contract documents or if such pay items are not applicable than at a price negotiated between the contractor and the Owner or at the unit bid price. If the Owner determines that extra work is to be performed, a change order will be issued.

5. CHANGE ORDERS

The Owner reserves the right to issue a formal change order for any increase, decrease, deletion, or addition of work or any increase in contract time or price. The contractor shall be required to sign the change order and it shall be considered as part of the Contract documents.

6. FINAL CLEANING UP

Before acceptance of the work, the contractor shall remove from the site all machinery, equipment, surplus materials, rubbish, temporary buildings, barricades and signs. All parts of the work shall be left in a neat and presentable condition. On all areas used or occupied by the contractor, regardless of the contract limits, the bidder shall clean-up all sites and storage grounds.

The items prescribed herein will not be paid for separately, but shall be paid for as part of the total contract price.

7. ERRORS AND INCONSISTENCY IN CONTRACT DOCUMENTS

Any provisions in any of the Contract Documents that may be in conflict with the paragraphs in these General Requirements shall be subject to the following order of precedence for interpretation.

1. Standard Specifications for Road & Bridge Construction will govern General Requirements.
2. Technical Specifications will govern Standard Specifications.
3. Plans will govern Technical Specifications, and General Requirements.

CONTROL OF WORK

1. AUTHORITY OF ENGINEER

(a) All work shall be done under supervision of the City Engineer and to his satisfaction. The City Engineer will decide all questions which may arise as to the quality and acceptability of materials furnished and work performed and as to the rate of progress of the work; all questions that may arise as to the interpretation of the plans and specifications; and all questions as to the acceptable fulfillment of the Contract by the Contractor.

(b) The City Engineer will have the authority to suspend the work wholly or in part for such periods as he may deem necessary due to the failure of the Contractor to correct conditions unsafe for workers or the general public; for failure to carry out provisions of the Contract; for failure to carry out orders; for conditions considered unsuitable for the prosecution of the work, including unfit weather; or for any other condition or reason deemed to be in the public interest. The Contractor shall not be entitled any additional payments arising out of any such suspensions.

(c) The Owner reserves the right to demand a certificate of compliance for a material or product used on the project. When the certificate of compliance is determined to be unacceptable to the City Engineer the Contractor may be required to provide engineering and testing services to guarantee that the material or product is suitable for use in the project, at its expense (see Sample of Certificate of Compliance).

2. PROTECTION AND RESTORATION OF PROPERTY AND LANDSCAPES

(a) The Contractor shall use every precaution to prevent injury or damage to wires, poles, or other property of public utilities; trees, shrubbery, crops, and fences along and adjacent to the right-of-way, all underground structures such as pipes and conduits, within or outside of the right-of-way; and the Contractor shall protect and carefully preserve all property marks until an authorized agent has witnessed or otherwise referenced their location.

(b) The Contractor shall be responsible for all damage or injury to property of any character, during the prosecution of the work, resulting from any act, omission, neglect, or misconduct in his manner or method of executing the work, or at any time due to defective work or materials, and said responsibility will not be released until the project shall have been completed and accepted.

(c) When or where any direct or indirect damage or injury is done to public or private property by or on account of any act, omission, neglect, or misconduct in the execution of the work, or as a result of the failure to perform work by the Contractor, the Contractor shall restore, at its own expense, such property to a condition similar or equal to that existing before such damage or injury was done, by repairing rebuilding, or otherwise restoring as may be directed, or the Contractor shall make good such damage or injury in an acceptable manner.

(d) The Contractor shall paint with tree paint all scars made on fruit or ornamental trees by equipment, construction operations, or the removal of limbs larger than one inch in diameter. Damaged trees must be replaced if so determined by the City Arborist, in his or her sole discretion.

(e) If the Contractor fails to repair, rebuild or otherwise restore such property as may be deemed necessary, the Owner, after 48 hours notice, may proceed to do so, and the cost thereof may be deducted from any money due or which may become due the Contractor under the contract.

(f) It is the intent of the Parties that the Contractor preserve, to as great an extent as possible, the natural features of the site.

CONTROL OF WORK (continued)

3. MAINTENANCE DURING CONSTRUCTION

The Contractor shall maintain the work during construction and until the project is accepted. This maintenance shall constitute continuous and effective work prosecuted day by day, with adequate equipment and workers to ensure that the structure is kept in satisfactory conditions at all times.

4. SAFETY PRECAUTIONS

Upon commencement of work, the Contractor shall be responsible for initiating, maintaining and supervising all safety precautions necessary to ensure the safety of employees on the site, other persons who may be affected thereby, including the public, and other property at the site or adjacent thereto.

5. PERMITS

It will be the responsibility of the Contractor to obtain all permits required for the operation of equipment in, or on, all city streets and public ways.

6. BARRICADES, WARNING SIGNS AND TRAFFIC OFFICERS

(a) The Contractor shall provide, erect and maintain all necessary barricades, suitable and sufficient lights, danger signals, signs and other traffic control devices, and shall take all necessary precautions for the protection of the work and safety of the public. Roadway closed to traffic shall be protected by effective barricades. Obstructions shall be illuminated during hours of darkness. Suitable warning signs shall be provided to control and direct traffic in a proper manner, as approved by the engineer.

(b) The Contractor will be held responsible for all damage to the work from traffic, pedestrians, animals or any other cause due to lack of adequate controlling devices.

(c) The Contractor shall provide such police officers as the City Engineer deems necessary for the direction and control of traffic within the site of project.

The work prescribed herein will not be paid for separately but will be paid for as part of the Contract Price unless specifically appearing as a bid item.

TEMPORARY FACILITIES

1. STORAGE FACILITIES

(a) The Contractor shall not store materials or equipment in a public right-of-way beyond the needs of one working day. Equipment and materials shall be stored in an approved location.

(b) The Contractor shall protect all stored materials from damage by weather or accident and shall insure adequate drainage at and about the storage location.

(c) Prior to final acceptance of the work all temporary storage facilities and surplus stored materials shall be removed from the site.

2. SANITARY FACILITIES

(a) The Contractor shall provide for toilet facilities for the use of the workers employed on the work.

(b) Temporary toilet facilities may be installed provided that the installation and maintenance conform with all State and local laws, codes, regulations and ordinances governing such work. They shall be properly lit and ventilated, and shall be kept clean at all times.

(c) Prior to final acceptance of the work all temporary toilet facilities shall be removed from the site.

3. TEMPORARY WATER

The Contractor shall make all arrangements with the local water department for obtaining water connections to provide the water necessary for construction operations and shall pay all costs.

4. TEMPORARY ELECTRICITY

The Contractor shall make all arrangements with the Public Service Company for obtaining electrical connections to provide the electrical power necessary for construction operations and security lighting and shall pay all electrical connection and power costs.

The Contractor shall be responsible with obtaining an electrical permit from the City Electrical Inspector.

INSURANCE REQUIREMENTS

Insurance shall be in such form as will protect the Contractor from all claims and liabilities for damages for bodily injury, including accidental death, and for property damage, which may arise from operations under this contract whether such operation by himself or by anyone directly or indirectly employed by him.

AMOUNT OF INSURANCE

- A) Comprehensive General Liability:
Bodily injury or Property Damage - \$2,000,000
Per occurrence and general aggregate
- B) Automobile and Truck Liability:
Bodily Injury or Property Damage - \$2,000,000
Per occurrence and general aggregate

Coverage amounts may be met with excess policies

Additionally, the Contractor shall purchase and maintain the following types of insurance:

- A) Full Workers Comprehensive Insurance coverage for all people employed by the Contractor to perform work on this project. This insurance shall at a minimum meet the requirements of the most current laws of the State of New Hampshire.
- B) Contractual Liability Insurance coverage in the amounts specified above under Comprehensive General Liability.
- C) Product and Completed Operations coverage to be included in the amounts specified above under Comprehensive General Liability.

ADDITIONAL INSURED

All liability policies (including any excess policies used to meet coverage requirements) shall include the City of Portsmouth, New Hampshire as named Additional Insureds.

- 1) The contractor's insurance shall be primary in the event of a loss.
- 2) City of Portsmouth shall be listed as a Certificate Holder. The City shall be identified as follows:

City of Portsmouth
Attn: Legal Department
1 Junkins Avenue
Portsmouth, NH 03801

MEASUREMENT AND PAYMENT

1. MEASUREMENT OF QUANTITIES

- (a) All work completed under the contract will be measured according to the United States standard measure.
- (b) The method of measurement and computations to be used in determination of quantities of material furnished and of work performed under the contract will be those methods generally recognized as conforming to good engineering practice. Unless otherwise stated all quantities measured for payment shall be computed or adjusted for "in place" conditions.
- (c) Unless otherwise specified, longitudinal measurements for area computations will be made horizontally, and no deductions will be made for individual fixtures having an area of 9 square feet or less. Unless otherwise specified, transverse measurements for area computations will be the dimensions shown on the plans or ordered in writing.
- (d) Structures will be measured according to lines shown on the plans or as ordered unless otherwise provided for elsewhere in the specifications.
- (e) In computing volumes of excavation, embankment, and borrow, the average end area method will be used. Where it is impracticable to measure by the cross-section method, acceptable methods involving three-dimensional measurement may be used. When measurement of borrow in vehicles is permitted, the quantity will be determined as 80 percent of the loose volume.
- (f) In computing volumes of concrete, stone and masonry, the prismatic method will be used. The term "ton" will mean the short ton consisting of 2,000 pounds avoirdupois.
- (g) Except as specified below, all materials that are measured or proportioned by weight shall be weighed on scales which the Contractor has had sealed by the State or by a repairman registered by the Commissioner of Agriculture. All weighing shall be performed in a manner prescribed under the Rules and Regulations of the Bureau of Weights and Measures of the New Hampshire Department of Agriculture.
- (h) Weighing of materials on scales located outside New Hampshire will be permitted for materials produced or stored outside the state, when requested by the Contractor and approved. Out-of-state weighing in order to be approved, must be performed by a licensed public weigh master or a person of equal authority in the state concerned on scales accepted in the concerned state.
- (i) Each truck used to haul material being paid for by weight shall bear a plainly legible identification mark, and if required, shall be weighed empty daily at such times as directed.
- (j) When material is weighed, the individual weight slips, which shall be furnished by the Contractor, for trucks, trailers, or distributors, shall show the following information: the date; the project; the material or commodity; the dealer or vendor; the Contractor or Subcontractor; the location of the scales; the vehicle registration number or other approved legible identification mark; the tare and net weights, with gross weights when applicable; and the weigher's signature or his signed initials.

MEASUREMENT AND PAYMENT (continued)

(k) The right is reserved to weight any truck, trailer, or distributor, at locations designated, before and after making deliveries to the project.

(l) Bituminous materials will be measured by the gallon or ton.

(m) When material is specified to be measured by the cubic yard but measurement by weight is approved, such material may be weighed and the weight converted to cubic yards for payment purposes. Necessary conversion factors will be determined by the Owner.

(n) The term "lump sum" when used as an item of payment will mean complete payment for the work described in the item.

(o) When a complete structure or structural unit (in effect, "lump sum" work) is specified as the unit of measurement, the unit will be construed to include all necessary fittings and accessories, so as to provide the item complete and functional. Except as may be otherwise provided, partial payments for lump sum items will be made approximately in proportion to the amount of the work completed on those items.

(p) Material wasted without authority will not be included in the final estimate.

2. SCOPE OF PAYMENT

(a) The Contractor shall receive and accept compensation provided for in the contract as full payment for furnishing all materials and for performing all work under the contract in a complete and acceptable manner and for all risk, loss, damage or expense of whatever character arising out of the nature of the work or the prosecution thereof.

(b) The Contractor shall be liable to the Owner for failure to repair, correct, renew or replace, at his own expense, all damage due or attributable to defects or imperfections in the construction which defects or imperfections may be discovered before or at the time of the final inspection and acceptance of the work.

(c) No monies, payable under the contract or any part thereof, except the first estimate, shall become due or payable if the Owner so elects, until the Contractor shall satisfy the Owner that the Contractor has fully settled or paid all labor performed or furnished for all equipment hired, including trucks, for all materials used, and for fuels, lubricants, power tools, hardware and supplies purchased by the Contractor and used in carrying out said contract and for labor and parts furnished upon the order of said Contractor for the repair of equipment used in carrying out said contract; and the Owner, if he so elects, may pay any and all such bills, in whole or in part, and deduct the amount of amounts so paid from any partial or final estimate, excepting the first estimate.

MEASUREMENT AND PAYMENT (continued)

3. COMPENSATION FOR ALTERED QUANTITIES

(a) Except as provided for under the particular contract item, when the accepted quantities of work vary from the quantities in the bid schedule the Contractor shall accept as payment in full, so far as contract items are concerned, at the original contract unit prices for the accepted quantities of work done. No allowance will be made for any increased expense, loss of expected reimbursement, or loss of anticipated profits suffered or claimed by the Contractor resulting either directly from such alterations or indirectly from unbalanced allocation among the contract items of overhead expense on the part of the Bidder and subsequent loss of expected reimbursements therefore or from any other cause.

(b) Extra work performed will be paid for at the contract bid prices or at the price negotiated between the Owner and the Contractor if the item was not bid upon. If no agreement can be negotiated, the Contractor will accept as payment for extra work, cost plus 15% (overhead and profit). Costs shall be substantiated by invoices and certified payroll.

4. PARTIAL PAYMENTS

Partial payments will be made on a monthly basis during the contract period. From the total amount ascertained as payable, an amount equivalent to five percent (5%) of the whole will be deducted and retained by the Owner until such time as the work receives final acceptance.

5. FINAL ACCEPTANCE

Upon due notice from the Contractor of presumptive completion of the entire project, the City Engineer will make an inspection. If all construction provided for and contemplated by the contract is found complete to his satisfaction, this inspection shall constitute the final inspection and the City Engineer will make the final acceptance and notify the Contractor in writing of this acceptance as of the date of the final inspection.

If, however, the inspection discloses any work in whole or in part, as being unsatisfactory, the City Engineer will give the Contractor the necessary instructions for correction of such work, and the Contractor shall immediately comply with and execute such instructions. Upon correction of the work, another inspection will be made which shall constitute the final inspection provided the work has been satisfactorily completed. In such event, the City Engineer will make the final acceptance and notify the Contractor in writing of this acceptance as of the date of final inspection.

MEASUREMENT AND PAYMENT (continued)

6. ACCEPTANCE AND FINAL PAYMENT

(a) When the project has been accepted and upon submission by the Contractor of all required reports, completed forms and certifications, the Owner will review the final estimate of the quantities of the various classes of work performed. The Contractor may be required to certify that all bills for labor and material used under this contract have been paid.

(b) The Contractor shall file with the Owner any claim that the Contractor may have regarding the final estimate at the same time the Contractor submits the final estimate. Failure to do so shall be a waiver of all such claims and shall be considered as acceptance of the final estimate. From the total amount ascertained as payable, an amount equal to ten percent (10%) of the whole will be deducted and retained by the Owner for the guaranty period. This retainage may be waived, at the discretion of the City, provided the required Maintenance Bond has been posted. After approval of the final estimate by the Owner, the Contractor will be paid the entire sum found to be due after deducting all previous payments and all amounts to be retained or deducted under the provisions of the contract.

(c) All prior partial estimates and payments shall be subject to correction in the final estimate and payment.

7. GENERAL GUARANTY AND WARRANTY OF TITLE

(a) Neither the final certification of payment nor any provision in the contract nor partial or entire use of the improvements embraced in this Contract by the Owner or the public shall constitute an acceptance of work not done in accordance with the Contract or relieve the Contractor of liability in respect to any express or implied warranties or responsibility for faulty materials or workmanship. The Contractor shall promptly remedy any defects in the work and pay for any damage to other work resulting therefrom which shall appear within a period of twelve (12) months from the date of final acceptance of the work. The Owner will give notice of defective materials and work with reasonable promptness.

(b) No material, supplies or equipment to be installed or furnished under this Contract shall be purchased subject to any chattel mortgage or under a conditional sale, lease purchase or other agreement by which an interest therein or in any part thereof is retained by the Seller or supplier. The Contractor shall warrant good title to all materials, supplies and equipment installed or incorporated in the work and upon completion of all work, shall deliver the same together with all improvements and appurtenances constructed or placed thereon by him to the Owner free from any claims, liens or charges. Neither the Contractor nor any person, firm or corporation furnishing any material or labor for any work covered by this Contract shall have the right to a lien upon any improvements or appurtenances thereon.

Nothing contained in this paragraph, however, shall defeat or impair the right of persons furnishing materials or labor to recover under any bond given by the Contractor for their protection or any rights under any law permitting such persons to look to funds due the Contractor in the hands of the Owner. The provisions of this paragraph shall be inserted in all subcontractors and material contracts and notice of its provisions shall be given to all persons furnishing materials for the work when no formal contract is entered into for such materials.

MEASUREMENT AND PAYMENT (continued)

8. NO WAIVER OF LEGAL RIGHTS

(a) Upon completion of the work, the Owner will expeditiously make final inspection and notify the Contractor of acceptance. Such final acceptance, however, shall not preclude or stop the Owner from correcting any measurement, estimate, or certificate made before or after completion of the work, nor shall the Owner be precluded or be stopped from recovering from the Contractor or his Surety, or both, such overpayment as it may sustain by failure on the part of the Contractor to fulfill his obligations under the contract. A waiver on the part of the Owner of any breach of any part of the contract shall not be held to be a waiver of any other or subsequent breach.

(b) The Contractor, without prejudice to the Contract shall be liable to the terms of the Contract, shall be liable to the Owner for latent defects, fraud or such gross mistakes as may amount to fraud, and as regards the Owner's right under any warranty or guaranty.

9. TERMINATION OF CONTRACTOR'S RESPONSIBILITY

Whenever the improvement provided for by the Contract shall have been completely performed on the part of the Contractor and all parts of the work have been released from further obligations except as set forth in his bond and as provided in Section 8 above.

STANDARD SPECIFICATIONS

The Standard Specifications for Road and Bridge Construction of the State of New Hampshire Department of Transportation and any Addenda shall apply.

SHOP DRAWINGS

Shop Drawings for this project shall be submitted under the following conditions:

1. The Contractor shall submit working and detail drawings, well in advance of the work, to the City Engineer & Building Inspector for review.
2. The Contractor's drawings shall consist of shop detail, erection and other working plans showing dimensions, sizes and quality of material, details and other information necessary for the complete fabrication and erection of the pertinent work.
3. The Contractor shall submit three (3) sets of drawings to the City Engineer.
4. Prior to the approval of the drawings, any work done or materials ordered for the work involved shall be at the Contractor's risk.
5. One (1) set of the drawings will be returned to the Contractor approved or marked with corrections to be made. After approval has been given, the Contractor shall supply the City Engineer with two sets of the revised detail working drawings.
6. The City Engineer's approval of the Contractor's working drawings will not relieve the Contractor from responsibility for errors in dimensions or for incorrect fabrication processes, or from responsibility to complete the contract work.

TECHNICAL SPECIFICATIONS

As noted above, the Standard Technical Specifications for this project are the Standard Specifications for Road and Bridge Construction of the State of New Hampshire Department of Transportation and any Addenda shall apply. Additional Technical Specifications and Special Provisions for this project are attached.

SPECIAL PROVISION

To Section 608 (NHDOT Standard Specifications) Sidewalks

Amend Section 608 to read:

**SECTION 608.24 & 608.26
CONCRETE HANDICAPPED RAMP CONSTRUCTION**

1.01 Scope of Work: The work shall consist of construction of concrete sidewalks as shown on the plans or as directed in the field by the Engineer.

1.02 Methods of Construction:

1.02a All labor and materials shall conform to the State of New Hampshire Standard Specifications for Road and Bridge Construction, Section 608, 203 and 209 except as amended here.

1.02b All concrete shall be Class A, 4000-PSI after 28 days with 5 to 7 percent air entrained. The maximum concrete slump that will be allowed is 5, this may be tested by the engineer at any time. All concrete will have polyfiber reinforcing. Any concrete found not meeting this specification will be removed and repoured by the contractor with no additional expense to the owner. Expansion joints shall be 25' apart. Control joints shall be 5' apart and shall be ¼ of the depth of the sidewalk (Up to 1 1/2" deep).

1.02c Minimum thickness shall be a full 4" or 6 inches (for 608.26) unless approved by the engineer.

1.02d The ends of all sidewalks at driveways shall be ramped at a maximum slope of 1:12.

1.02e All sidewalks shall have handicap ramps at street intersections or as located by the Engineer, built at a maximum slope of 1:12 and in accordance with the ADA Regulations (see plan details).

1.02f Excavation for new sidewalks shall be at a depth of 12 inches below finish grade. In areas not butting curbing or buildings the excavation shall be 6 inches wider on each side than the finished sidewalk width. At all drive crossings, the depth of excavation shall be increased accordingly. All unsuitable material shall be approved by the Engineer and removed and disposed of offsite at the Contractor's own expense. At no time will unsuitable material be left under sidewalk areas.

1.02g Handicapped ramps (at street intersections) shall be 6" deep, 4000 psi fiber mix reinforced with 6" x 6" x 10ga welded wire mesh with truncated dome panels (panels paid for under 608.52).

1.02h All exposed surfaces of sidewalks will be sealed with an approved Silane-Siloxane coating as specified under 534.3.4. Any sidewalks not meeting the test referenced in 534.3.4 will be recoated at no expense to the owner. Contractor will provide cut sheets on product before installation for engineers approval.

1.02i All sidewalk areas shall be thoroughly wetted and compacted prior to the pouring of any concrete. On days exceeding 80 degrees, all sidewalks will be kept damp using wet burlap tarps or any other approved method for 24 hours after set up. Tarps will be staked down to prevent being blown off by wind gusts. Curing compounds will be considered an approved equal.

1.02j All sidewalks will be finished with a soft broom with the finish being transverse to the typical pedestrian path. After brooming, all edges will be finish edged.

1.02k Any sidewalks poured that have excessive “popcorning” on top or on the sides as determined by the engineer will not be approved or paid for.

1.02l All joints shall be straight, even and perpendicular to the sidewalk.

1.03 Methods of Measurement:

This work shall be measured by the square yard of concrete sidewalk successfully & completely installed and approved by the Engineer.

1.04 Basis of Payment:

This work shall be paid for at the Contract Unit Price as listed in Item #608.24 & 608.26 in the Bid Specification.

This price shall include all equipment, material and labor incidental hereto.

Item 608.52 – ADA Compliant Handicap Ramp Panels

Description

1.1 This work shall consist of furnishing and installing a detectable warning surface and accessories on sidewalk ramps at locations shown on the plans, as specified herein, or as ordered including any and all required surface preparation. Detectable warnings shall be installed at sidewalk ramps where a sidewalk crosses a vehicular way, excluding unsignalized driveway crossings. The edge nearest the curblin e shall be located 150 to 200 mm (6 to 8 in) from the face of curblin e. The paver shall be centered on the ramp.

Materials

2.1 Detectable Warning Device:

2.1.1 Material. The detectable warning surface shall consist of Engineered Plastic units or approved equal. The units will be pressed into Portland cement or other Owner approved material.. The paver units shall be Armor Tile as manufactured and supplied by Engineered Plastic, Inc., 300 International Dr Suite 100, Williamsville, NY 14221, 1-800-769-4463, www.armor-tile.com

2.1.2 Color. The color of the tile used shall be **brick red (#22144)**, all would be installed in a concrete ramp as described above (608.26).

2.1.3 Paver Dimensions. Nominal paver dimensions shall be 2’ deep x 3’ wide.

2.1.4 Detectable Warning Truncated Dome Geometry:

2.1.4.1 Detectable warnings shall be in full compliance with ADAAG guidelines (Title 49 DFR Transportation, Part 37.9 Standard for Accessible Transportation Facilities, Appendix A, Section 4.29.2- Detectable Warning on Walking Surfaces).

2.1.4.2 Size and spacing for truncated domes shall be as follows: base diameter of nominal 0.9 inch, top diameter of nominal 0.4 inch, height of nominal 0.2 inch, with a center to center spacing of nominal 2.35 inches.

2.1.4.3 The truncated dome pattern shall align properly from paver to paver if more than 1 paver is required.

2.2 Setting Bed Material

2.2.1 Material. Pavers shall be set into fresh concrete before it sets. See ramp specification above (608.26). Also see manufacturer instructions.

Construction Requirements

- 3.1** The Contractor shall submit manufacturer's installation instructions and descriptive literature for materials specified herein.
- 3.2** Transport, storage, and handling of products shall be in accordance with manufacturer's instructions.
- 3.2.1** All sealants/adhesives shall be protected from freezing conditions.
- 3.3** The air and surface temperatures during construction shall be in accordance with manufacturer's recommendations.
- 3.4** Concrete foundation shall be installed in accordance with the specifications included within Section 608 to depths indicated in the section shown on the plans.
- 3.5** Install detectable warning pavers in accordance with manufacturer's instructions directly in the setting bed and the allowing the top surface of the paver units to be at or just below the required finish grade.
- 3.6** Care shall be taken to ensure the safety of pedestrians when sidewalks must remain in service during construction.

Method of Measurement

- 4.1** These are measured by each panel installed under the truncated dome panel item.

Basis of Payment

Pay Item and Unit

608.52 Truncated Dome Pavers (Detectable Warning Pavers Only) Each

TECHNICAL SPECIFICATIONS

SPECIAL PROVISION

To Section 616A (NHDOT Standard Specifications) Traffic Signals

Summary

The City plans to upgrade the pedestrian crossing signals in the Granite Street/Woodbury Avenue Intersection. New pedestrian push buttons and walk lights are to be installed including two new pedestal mounted pedestrian signals.

All proposed traffic signal work shall conform to the New Hampshire Department of Transportation (NHDOT) 2006 Standard Specifications for Road and Bridge Construction, the Current *Manual on Uniform Traffic Control Devices*, or as amended in these documents.

Add to Description:

1.3 This work shall consist of furnishing and installing traffic signals with all work necessary to make the installation complete, at the following location:

- Intersection of Woodbury Avenue and Granite Street

Amend 2.2.1 to read:

2.2.1 Housings. Housings shall be constructed of aluminum with a smooth outer surface and shall be capable of holding the optical units securely in place. Housings shall be adaptable for pedestal, bracket, or rigid mast-arm vertical or horizontal mounting. The assembled housing shall be dust proof and moisture proof. Each housing shall be equipped with a hinged door of aluminum to hold the LED indication of the optical units. The doors shall be designed to insure uniform pressure around the door frame when closed. Doors shall be fastened by hinged wing nuts assemblies or other approved fasteners. Unless otherwise indicated on the plans, lenses shall be furnished with approved sun shield visors, not less than 250 mm (10 in) in length. If longer visors than those specified above are deemed necessary, they shall be furnished and installed. All traffic signals shall be furnished with a 125 mm (5 in) louvered, aluminum backplate. Backplates shall be fastened with stainless steel hex head slotted screws and a 5 by 19 mm (3/16" by 3/4") stainless steel fender washer. Where specified as 'yellow', traffic signal housings and backplates shall be black.

Amend 2.2.3 to read:

2.2.3 Mast arm brackets. Mast arm brackets shall be Astro-Brac, or approved equal.

Add to 2.2.5:

2.2.5.3 All new signal head modules shall be of the 12-inch LED type, Siemens ITS™ brand, or approved equal.

Amend 2.3.1 to read:

2.3.1 General. Pedestrian signal heads shall be of the LED type conforming to the Institute of Transportation Engineers Standard for Adjustable Face Pedestrian Signal Heads. All heads shall be square in shape.

Amend the first sentence in 2.3.2 to read:

Housings shall be yellow, one piece die cast aluminum alloy complete with top, bottom, sides, and back.

Amend 2.3.3 to read:

2.3.3 Pedestrian Indications. The pedestrian signal heads shall be furnished complete with a symbolic LED hand/man overlay with full image.

Amend 2.3.4 to read:

2.3.4 Pedestrian Detectors. Pedestrian pushbuttons shall be installed at 33 inches above the walking surface or in accordance with the most recent publication of "The Americans with Disabilities Act Accessibility Guidelines for Buildings and Facilities (ADAAG)."

Amend the last sentence in 2.5.1.2.1 to read:

When all of the above procedures have been completed, the performing technician shall document with a signature the results on the approved form as provided by the City of Portsmouth.

Amend 2.8 to read:

2.8 Painting. Prior to erection and assembly, the entire traffic or pedestrian signal housing and visors shall be checked for damaged paint and repaired/painted as necessary.

Amend 3.1.1 to read:

3.1.1 A preconstruction meeting with the Contractor, signal subcontractor, Engineer and City of Portsmouth representative shall be arranged not less than 3 days prior to the start of signal installation, to resolve any problems.

Add to Construction Requirements:

3.2.1 Prior to final acceptance of the construction, the Contractor, together with the Engineer, shall inspect the traffic signal system, mast arms and poles, and denote any damaged or missing parts. Damaged or missing parts shall be repaired/replaced as directed by the Engineer. The hand hole cover plates and caps for the arms and mast will be provided by the contractor.

3.2.1.1 Any damage to the traffic signal system after the inspection, but before final written acceptance of the construction/installation by the City of Portsmouth shall be repaired/replaced as directed by the Engineer and at the Contractor's expense.

3.2.1.2 All existing signal equipment not being retained shall be salvaged to the City of Portsmouth Department of Public Works, or disposed of at their direction.

3.2.1.3 Damaged galvanized surfaces shall be repaired by applying an organic zinc repair paint conforming to ASTM A 780. Galvanizing repair paint shall have 75% zinc minimum by weight and shall be brush applied. The thickness of the repair coat shall not be less than the coating thickness required by AASHTO M 111 or M 232, but not less than 3 mils (75 microns) DFT. Repair touch-up using aerosol spray, silver paint, bright paint, brite paint, or aluminum paint shall not be permitted.

Amend 3.12 to read:

3.12 Painting. All paint shall conform to Section 708 unless otherwise specified. The following colors of enamel shall be used:

- | | | | |
|-----|------------|----------------|-----------------|
| (a) | Housings | yellow | |
| (b) | Backplates | black | |
| (c) | Visors | Inside: black; | Outside: yellow |

After the signals have been completely installed, two coats of enamel shall be applied to all unpainted or scratched surfaces after the surface has been lightly sanded to remove gloss.

4.1 Traffic signals will be measured as a unit, including furnishing and all components and labor.

Add to Method of Measurement:

4.2 Components damaged due to the Contractor's operations or negligence shall be repaired/replaced at the Contractor's expense.

Amend 5.1 to read:

5.1 The accepted quantity of traffic signals will be paid for at the contract lump sum price complete in place.

GENERAL:

All provisions of Section 616, except as modified or changed below, shall apply.

1. The Contractor shall be responsible for signal operation and maintenance once any feature of the signal is disturbed. The Contractor shall furnish the Contract Administrator, City of Portsmouth Department of Public Works with names and phone numbers of persons to be contacted in case of a malfunction.
2. The Contractor shall be responsible for the dismantling and removing of the existing traffic control system. All equipment shall be salvaged to the City of Portsmouth Department of Public Works in Portsmouth.
3. The existing power source shall be retained.
4. The work at this intersection includes the modification of the existing traffic control system. Work includes, but is not limited to, the installation of pedestrian signal heads, pedestrian push buttons, traffic signal conduit, and all other ancillary equipment necessary to provide a complete and functional traffic control system. The Contractor shall locate the proposed structure locations per the plans.

Add to 2.1:

2.1.3 List of Major Materials

- 2 - 8 ft aluminum pedestrian pedestal signal pole manufactured by Alloy Castings Co Model #ACTB-20-695 or approved equal with foundation.
- 4 - Aluminum, 12-inch, Leotek solid LED, symbolic bi-modal pedestrian signals.
- 3- Pedestrian push button and sign, Pelco model SE-2037-08 and Pelco Model SF-1018-05, or equal.

All electrical wire, connectors, conduit, etc.

TECHNICAL SPECIFICATIONS

SPECIAL PROVISION

To Section 616B (NHDOT Standard Specifications) Traffic Signals

Summary

The City wishes to upgrade the existing **two** school flashing signs that are located on Woodbury Avenue and are used for the New Franklin School. The new units are to have radar units which will flash the oncoming vehicle's speed if the vehicle is exceeding the preset limit. The units are to be placed as shown on the construction plans. The units will be installed on a concrete foundation with 1 1/2" sch 80 pvc conduit that runs to the previous power supply for the existing units. The contractor is responsible for all materials for complete installation including the power supply. The contractor will be responsible for contacting and scheduling with PSNH for transfer from the existing units to the proposed units. The contractor will get an electrical permit from the City of Portsmouth and will schedule inspections. The existing school signs will be removed by the contractor and are property of the City of Portsmouth. A flashing school zone signal (8" amber LED) will be mounted on top a 12' aluminum pedestrian pedestal signal pole manufactured by Alloy Castings Co Model #ACTB-20-695 or approved equal with foundation. A school zone voluntary speed compliance sign (Information Display Co. #VSC-1520F) shall be provided as shown. The voluntary sign will be mounted underneath the school zone sign on the same post assembly. Ensure 6 1/2' clearance under the unit. Provide Nema 3R flasher cabinet #FC101 mounted on pole to control flashing beacon. See detail on Drawings.

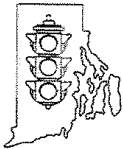
	Ocean State Signal Co. 27 Thurber Blvd • Smithfield, RI 02917 (401) 231-6780 Fax: (401) 231-4390	
	SPECIFICATION SHEET	TITLE: NEMA ENCLOSURE - 14"H x 11"W x 11"D Flasher Cabinet w/NEMA Flasher & AP21 Time Switch

Item	Part Description	Qty
1	Flasher Sub-base	1
2	NEMA Flasher Sub-base Bracket	1
3	Plastic Ground Bus Bar Insulator Stand	1
4	Brass Ground Bus Bar	1
5	Grounding Nut	1
6	4-Point Terminal Block	1
7	10Amp Circuit Breaker Switch	1
8	Solid State NEMA Flasher	1
9a	NEMA Flasher Cabinet - unpainted	1
9b	NEMA Flasher Cabinet - painted	1
10	Programmable Time Switch	1

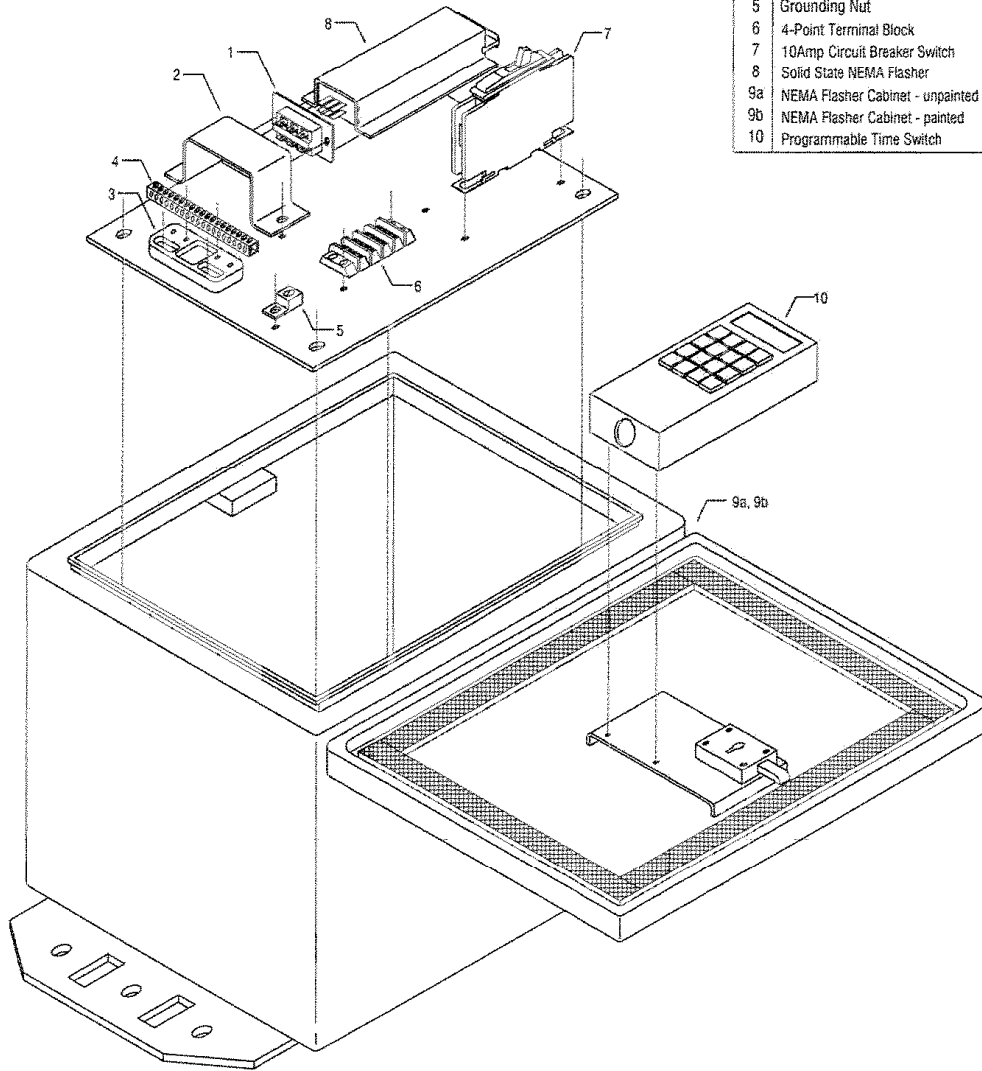

For more information, visit our website at www.oceanstatesignal.com



FEATURES

Fluorescent Yellow-Green (MUTCD Pedestrian, Bicycle, School) or **Standard Yellow** sign colors.

Violation Alert - Display flashes when a pre-set speed is exceeded. To convey increased urgency, the display flashes more rapidly as speed increases.

Controlled viewing area prevents distracted driving - Our exclusive SafetyMask™ technology allows display viewing *only* when within a driver's normal field of view. Prevents viewing from acute angles to avoid distracting a driver's attention to the side of the road at a time when it is critical that their attention is on the road *ahead*.

UltraClear™ contrast enhancement technology provides the ultimate in display visibility.

100% solid-state - no moving parts to wear, stick or break.

AC and Solar power options

Unbreakable 1/4" Polycarbonate window

Full 2 year warranty - 8 year warranty on LEDs

Speed-CHECK

VSC - 1520F

Voluntary Speed Compliance
Display system

GENERAL SPECIFICATIONS

Dimensions:

Display Housing: 26 1/2" x 20" x 6"
(67 x 51 x 15 cm)

Sign Dimensions: 30" x 42"
(76 x 107 cm)

Weight: 31 Lbs. (15.5 kg.)

Numeral Height: 15" (38 cm)

Construction:

Heavy (11 Gauge) Welded Aluminum
11 Gauge Aluminum Sign
Stainless Steel & Brass hardware

Display Type: AllnGaP LED

ELECTRONIC DATA

Power:

110 / 220 VAC or
10 - 16 volts DC (Solar Panel)

RADAR type:

Low power - 24.150 Ghz (K-band)

FCC approval:

Part 15 Certified
No operating license required

INFORMATION DISPLAY COMPANY

Box 19640 - Portland, Oregon 97280 - USA (800) 421-8325 / (503) 678-2861 fax: (503) 678-2863
sales@informationdisplay.com

Specification Sheet for MODEL ACTB-20-695



Single Pole and Base

Available in 8' and 10' lengths

From: ALLOY CASTINGS CO., INC.
Quality Aluminum Castings Since 1948

151 West Union Street • East Bridgewater, MA 02333-0473
Telephone: (508) 378-2541 • FAX: (508) 378-1240
www.alloycastings.com

MATERIAL SPECIFICATIONS...

POLE: 6063-T6 Aluminum
 .156 Wall Thickness with a 6" to 4 1/2" Taper
 Other wall thicknesses are available. Variations in Taper are also available.
 M.I.G. welding is done using a 5356 aluminum alloy wire.
 Continuously welded to the inside and outside of the base.
 Vibration dampers are available.
 Satin Brush Finish.
 All Pole Lengths are available.
 3', 4' 4", 8', 10' and 12' are in stock.

BASE: 356 Cast Aluminum. Base contains an internal grounding stud for the purpose of attaching a ground connector.
 Removable 8 5/16" x 13 5/16" x 10" door.
 Vandal Resistant 304 Stainless Steel Screw is used to lock door.
 All Hardware is 304 Stainless Steel.
 One Coat Bituminous Paint on bottom of base.
 Anchor Bolts are available 3/4" x 25" long 4" thread and 4" hook.
 Galvanized Steel with Nuts, lock Washers and Flat Washers. 4 each required.

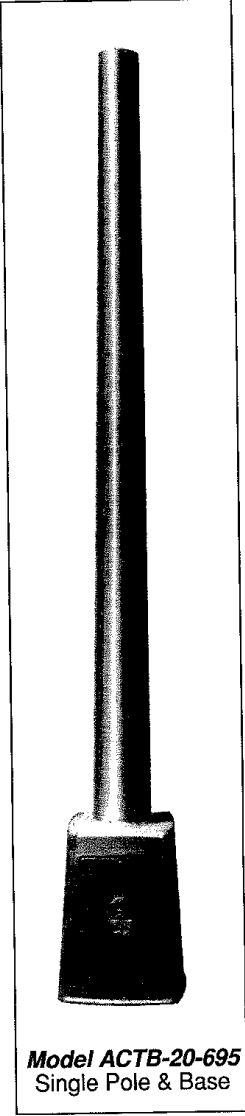
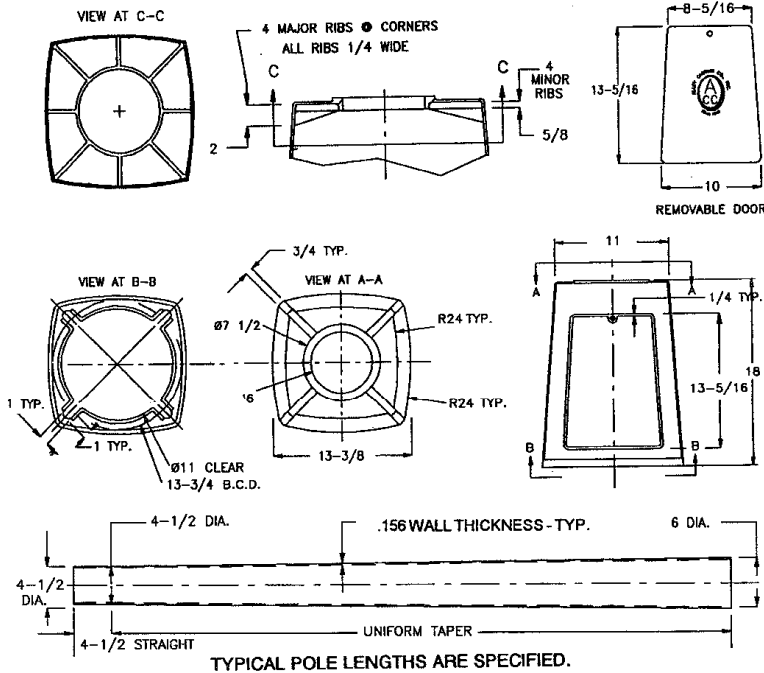

**SECTION 670
PAINTING OF BRIDGE ABUTMENTS**

1.01 Scope of Work: The work consists of cleaning, priming and repainting the concrete bridge abutments under route 95 where it crosses over Woodbury Ave.

Description

1 The walls are to be pressure washed to remove all grime, dirt, pollutants, loose paint etc. Engineer to inspect and approve of cleaning before priming/Painting may begin. After cleaning, paint primer will be installed once the wall has dried. It is anticipated that the wall may take 2-7 days to fully dry after washing. Finally an Elastomeric paint will be installed.

Materials

- 1 Paint Primer is to be Benjamin Moore Fresh Start Primer #023. Install over entire abutment from top to bottom and end to end.
- 2 Paint is to be Benjamin Moore Moorlastic low luster #055. Color to be **Bone White** (Color 03) Install over entire abutment from top to bottom and end to end.

Construction Requirements

1 Install products per Manufacturers Specifications. Contractor is responsible for cleaning, priming, painting, staging if required, and clean up. The product is to be applied in a neat and clean matter being careful not to get overspray on other adjacent surfaces or passing vehicular or pedestrian traffic. Contractor will provide "fresh paint" signs, barricades or whatever is necessary to protect the work and the public.

Method of Measurement

1 This item is measured by the square foot of finished work.

Basis of Payment

Pay Item and Unit

670	Pressure Wash, prime & Paint Route 95 Bridge Abutments	Square Foot
-----	--	-------------