

L-0700-017
May 20, 2019

Ms. Juliet Walker, Planning Director
City of Portsmouth Planning Department
1 Junkins Avenue
Portsmouth, New Hampshire 03801

**Re: Lonza Biologics G2E– Proposed Industrial Improvements
Site Plan Review Application**

Dear Juliet:

On behalf of Lonza Biologics, we are pleased to submit the following information to support a request to the Planning Board for a recommendation for approval to the Pease Development Authority (PDA) for Site Plan Review for proposed exterior improvements along Goose Bay Drive in the rear of its existing facility that is located at 101 International Drive:

- Ten (10) copies of the PDA Application for Site Review dated May 1, 2019
- Ten (10) copies of the Owner Authorization dated May 1, 2019;
- Three (3) full size & seven (7) half size copies of the Site Plan Set dated May 20, 2019;
- Ten (10) copies of the Drainage Analysis Memorandum dated May 20, 2019;
- Ten (10) copies of the Generator Cut Sheet;
- One (1) application fee calculation forms for the Site Review Permit;
- One (1) Site Review Application Fee check in the amount of \$1,050.00;
- One (1) CD containing digital copies of the above listed materials

The proposed project is located at 101 International Drive which is identified as Map 305 Lot 6 on the City of Portsmouth Tax Maps. The proposed project includes exterior improvements to support on-going improvements occurring inside the building. The exterior improvements can be summarized as follows:

- Proposed 500 SF single-story building addition in the rear of 101B
- Replace an existing 1,500-gallon nitrogen tank to new 6,000-gallon nitrogen tank and upgrade the existing concrete pad as needed in the rear of 101B
- Proposed electrical improvements in the rear of 101C including a two (2) new generators with 3,312-gallon diesel fuel above ground storage tanks (AST), a transformer pad, switchgear housed in an enclosure, automatic transfer switch housed in a proposed enclosure and an associated retaining wall.

The first two (2) items listed above can be approved administratively by the Pease Development Authority (PDA). PDA has indicated the third item will require Site Review approval. On April 18, 2019, the PDA Board granted conceptual approval for these improvements.

We respectfully request to be places on the Technical Advisory Committee (TAC) meeting agenda for June 4, 2019. If you have any questions or need any additional information, please contact Patrick Crimmins by phone at (603) 433-8818 or by email at pmcrimmins@tighebond.com.



Sincerely,
TIGHE & BOND, INC.

A handwritten signature in blue ink, appearing to read "P M C", with a long horizontal flourish extending to the right.

Patrick M. Crimmins, PE
Senior Project Manager

A handwritten signature in blue ink, appearing to read "Neil Hansen", with a long horizontal flourish extending to the right.

Neil A. Hansen, PE
Project Engineer

Cc: Lonza Biologics (via email)
Pease Development Authority (via email)

PROPOSED INDUSTRIAL IMPROVEMENTS

101 INTERNATIONAL DRIVE
PORTSMOUTH, NEW HAMPSHIRE

PROJECT NO: L-0700-017

APRIL 8, 2019

REVISED: MAY 20, 2019

LIST OF DRAWINGS		
SHEET NO.	SHEET TITLE	LAST REVISED
	COVER SHEET	5/20/2019
C-101	EXISTING CONDITIONS PLAN	5/20/2019
C-102	SITE PLAN	5/20/2019
C-103	GRADING, DRAINAGE, EROSION CONTROL & UTILITIES PLAN	5/20/2019
C-501	EROSION CONTROL NOTES & DETAILS SHEET	5/20/2019
C-502	DETAILS SHEET	5/20/2019

LIST OF PERMITS		
LOCAL	STATUS	DATE
SITE PLAN REVIEW PERMIT	PENDING	

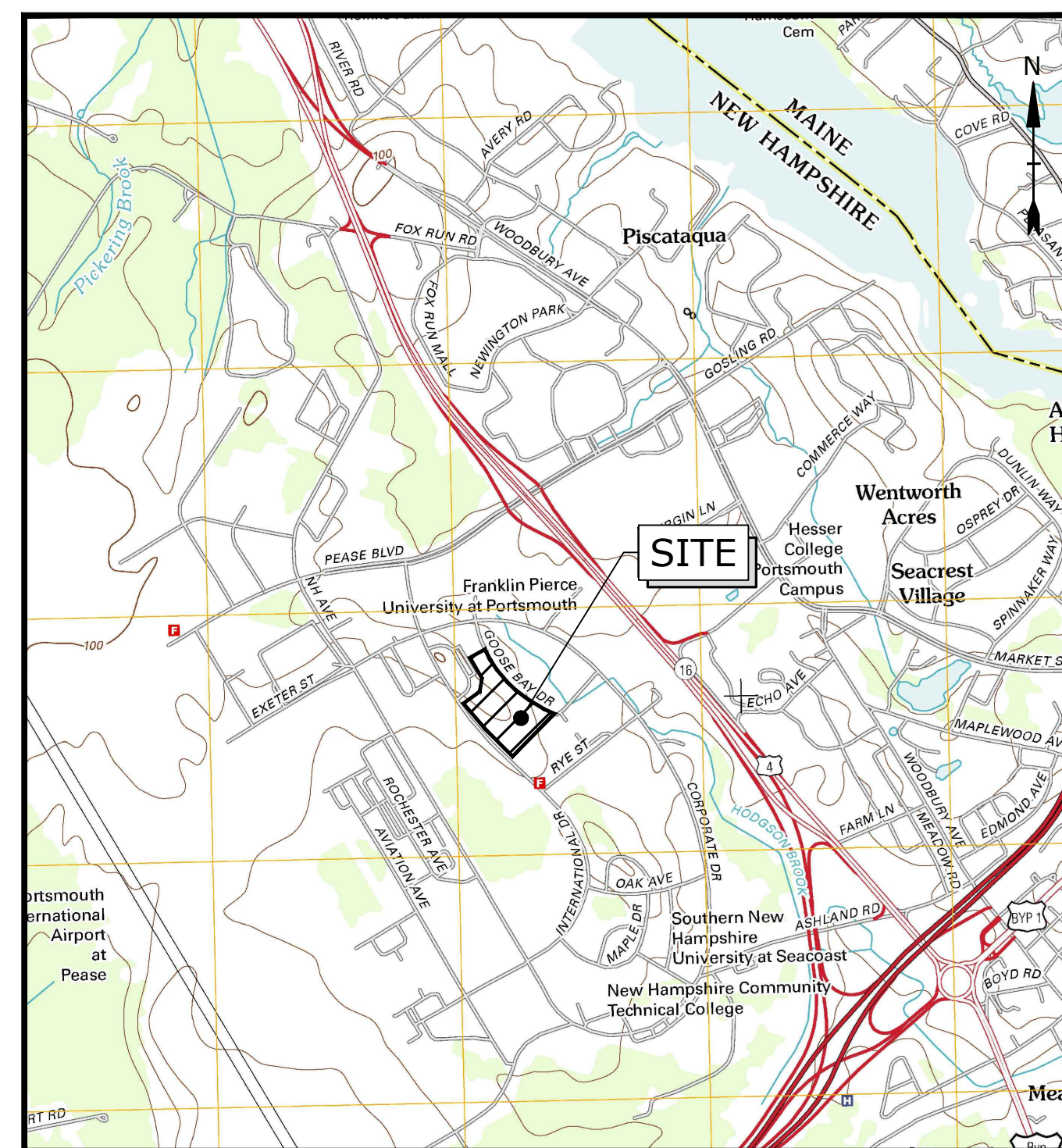

LOCATION MAP
SCALE: 1" = 2,000'

OWNER:

PEASE DEVELOPMENT AUTHORITY
55 INTERNATIONAL DRIVE
PORTSMOUTH, NEW HAMPSHIRE 03801

CLIENT:

LONZA BIOLOGICS
101 INTERNATIONAL DRIVE
PORTSMOUTH, NH 03801

CIVIL ENGINEER:

Tighe&Bond
Engineers | Environmental Specialists
177 CORPORATE DRIVE
PORTSMOUTH, NEW HAMPSHIRE 03801

SURVEYOR:

DOUCET SURVEY, INC.
102 KENT PLACE
NEWMARKET, NEW HAMPSHIRE 03857



**TAC SUBMISSION
COMPLETE SET 6 SHEETS**



LEGEND

○	CHAIN LINK FENCE
—	GUARDRAIL
—	OVERHEAD WIRE
SS	SEWER LINE
—	DRAIN LINE
G	GAS LINE
W	WATER LINE
E	UNDERGROUND ELECTRIC LINE
T	UNDERGROUND TELEPHONE LINE
---	MAJOR CONTOUR LINE
---	MINOR CONTOUR LINE
- - -	EDGE OF WATER
[Pattern]	CONCRETE
[Pattern]	RIP RAP
[Pattern]	CRUSHED STONE
○	UTILITY POLE & GUY WIRE
●	BOLLARD
⊕	FIRE HYDRANT
⊕	WATER GATE VALVE
⊕	PAD MOUNTED TRANSFORMER
⊕	CATCH BASIN
⊕	DRAIN MANHOLE
⊕	FLARED END SECTION
⊕	ELECTRIC MANHOLE
⊕	SEWER MANHOLE
⊕	CLEANOUT
X 66.5	SPOT GRADE
tw	TOP OF WALL ELEVATION
bw	BOTTOM OF WALL ELEVATION
TYP.	TYPICAL
CONC.	CONCRETE
COND.	CONDUIT
TH	THRESHOLD
EP	EDGE OF PAVEMENT
EOG	EDGE OF GRAVEL
VGC	VERTICAL GRANITE CURB
SBB	SLOPED BITUMINOUS BERM

- NOTES:**
- REFERENCE: LONZA BIOLOGICS D.S. PROJECT NO. 5855
 - FIELD SURVEY PERFORMED BY J.P.E. & L.P.S. ON FEB. 12 & 13, 2019 USING A TRIMBLE S7 TOTAL STATION WITH A TRIMBLE TSC3 DATA COLLECTOR AND A TRIMBLE DINI DIGITAL AUTO LEVEL. TRAVERSE ADJUSTMENT BASED ON LEAST SQUARE ANALYSIS.
 - ADDITIONAL FIELD SURVEY PERFORMED BY W.J.D. ON FEB. 12, 2019 USING A LEICA HDS SCANNER. REGISTRATION ADJUSTMENT BASED ON LEAST SQUARE ANALYSIS.
 - HORIZONTAL DATUM BASED ON NH STATE PLANE 2800(NAD83/86) PER PREVIOUS WORK COMPLETED BY THIS FIRM AT THE SITE.
 - VERTICAL DATUM IS BASED ON NGVD29 PER PREVIOUS WORK COMPLETED BY THIS FIRM AT THE SITE.
 - PROPER FIELD PROCEDURES WERE FOLLOWED IN ORDER TO GENERATE CONTOURS AT 1' INTERVALS. ANY MODIFICATION OF THIS INTERVAL WILL DIMINISH THE INTEGRITY OF THE DATA, AND DUCET SURVEY, INC. WILL NOT BE RESPONSIBLE FOR ANY SUCH ALTERATION PERFORMED BY THE USER.
 - UNDERGROUND UTILITIES SHOWN HEREON ARE BASED ON OBSERVED PHYSICAL EVIDENCE AND PAINT MARKS FOUND ON-SITE.
 - THE ACCURACY OF MEASURED UTILITY INVERTS AND PIPE SIZES/TYPES IS SUBJECT TO NUMEROUS FIELD CONDITIONS, INCLUDING; THE ABILITY TO MAKE VISUAL OBSERVATIONS, DIRECT ACCESS TO THE VARIOUS ELEMENTS, MANHOLE CONFIGURATION, ETC.
 - ALL UNDERGROUND UTILITIES (ELECTRIC, GAS, TEL. WATER, SEWER DRAIN SERVICES) ARE SHOWN IN SCHEMATIC FASHION, THEIR LOCATIONS ARE NOT PRECISE OR NECESSARILY ACCURATE. NO WORK WHATSOEVER SHALL BE UNDERTAKEN USING THIS PLAN TO LOCATE THE ABOVE SERVICES. CONSULT WITH THE PROPER AUTHORITIES CONCERNED WITH THE SUBJECT SERVICE LOCATIONS FOR INFORMATION REGARDING SUCH. CALL DIG-SAFE AT 1-888-DIG-SAFE.

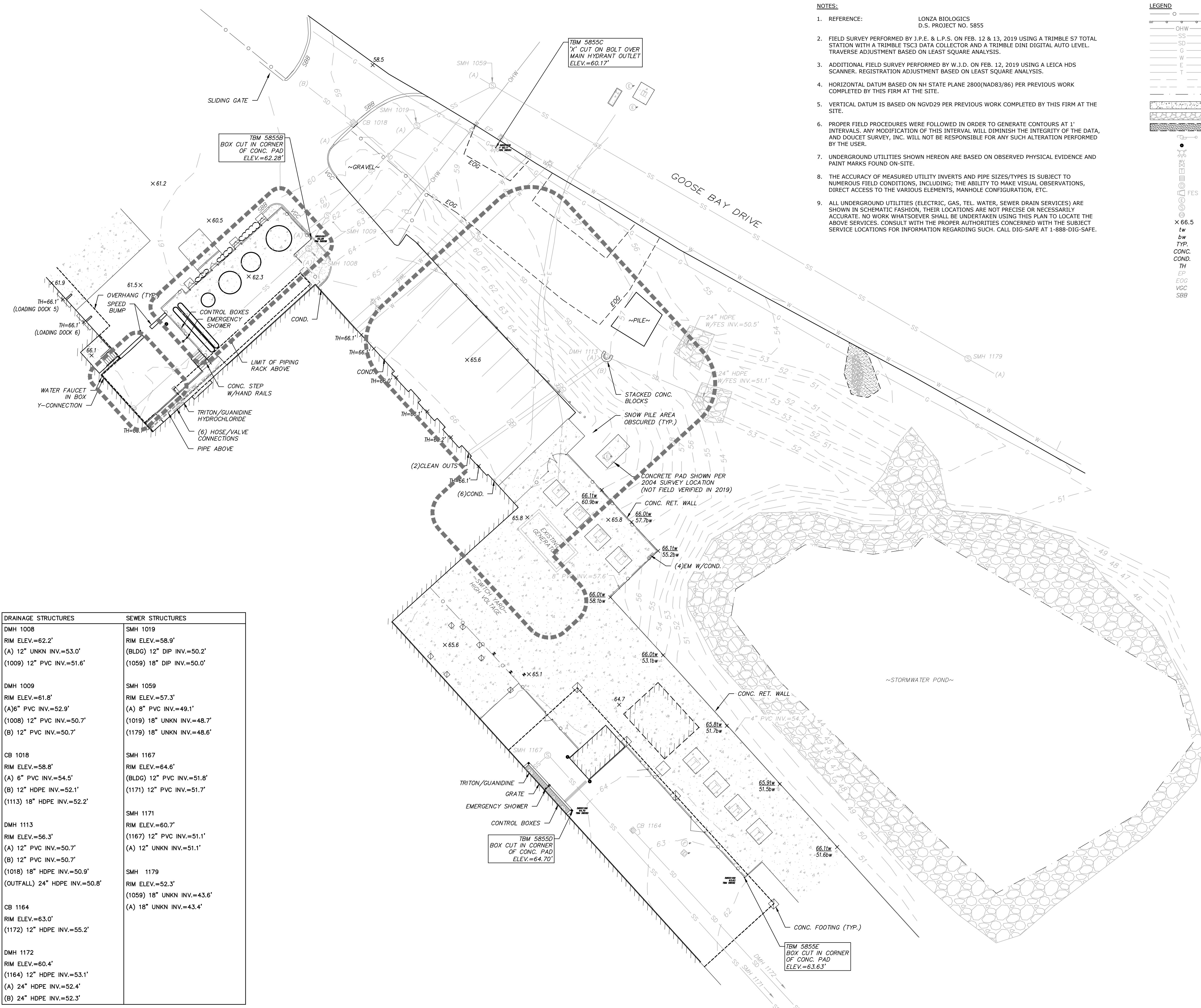

DRAINAGE STRUCTURES	SEWER STRUCTURES
DMH 1008 RIM ELEV.=62.2' (A) 12" UNKN INV.=53.0' (1009) 12" PVC INV.=51.6'	SMH 1019 RIM ELEV.=58.9' (BLDG) 12" DIP INV.=50.2' (1059) 18" DIP INV.=50.0'
DMH 1009 RIM ELEV.=61.8' (A) 6" PVC INV.=52.9' (1008) 12" PVC INV.=50.7' (B) 12" PVC INV.=50.7'	SMH 1059 RIM ELEV.=57.3' (A) 8" PVC INV.=49.1' (1019) 18" UNKN INV.=48.7' (1179) 18" UNKN INV.=48.6'
CB 1018 RIM ELEV.=58.8' (A) 6" PVC INV.=54.5' (B) 12" HDPE INV.=52.1' (1113) 18" HDPE INV.=52.2'	SMH 1167 RIM ELEV.=64.6' (BLDG) 12" PVC INV.=51.8' (1171) 12" PVC INV.=51.7'
DMH 1113 RIM ELEV.=56.3' (A) 12" PVC INV.=50.7' (B) 12" PVC INV.=50.7' (1018) 18" HDPE INV.=50.9' (OUTFALL) 24" HDPE INV.=50.8'	SMH 1171 RIM ELEV.=60.7' (1167) 12" PVC INV.=51.1' (A) 12" UNKN INV.=51.1'
CB 1164 RIM ELEV.=63.0' (1172) 12" HDPE INV.=55.2'	SMH 1179 RIM ELEV.=52.3' (1059) 18" UNKN INV.=43.6' (A) 18" UNKN INV.=43.4'
DMH 1172 RIM ELEV.=60.4' (1164) 12" HDPE INV.=53.1' (A) 24" HDPE INV.=52.4' (B) 24" HDPE INV.=52.3'	

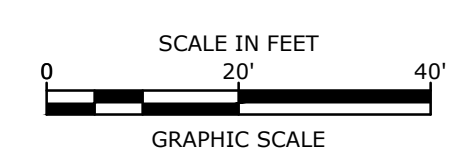
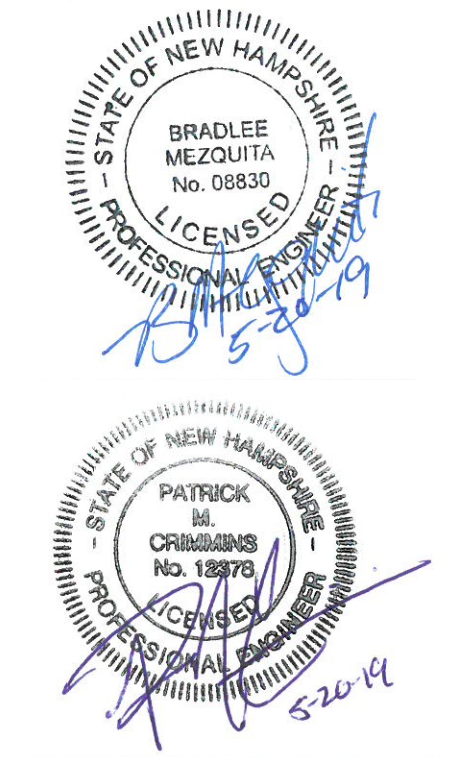

G2E Generator

Lonza Biologics

Portsmouth,
New Hampshire

MARK	DATE	DESCRIPTION
E	5/17/2019	TAC Submission
D	5/7/2019	TAC Work Session
C	5/1/2019	BOA Submission
B	4/10/2019	Revised PDA Submission
A	4/8/2019	PDA Submission

PROJECT NO:	L0700-017
DATE:	04/08/2019
FILE:	L0700-017_C-DSGN.dwg
DRAWN BY:	NAH
CHECKED:	PMC
APPROVED:	BLM

EXISTING CONDITIONS PLAN

SCALE:
C-101

Last Saved: 5/17/2019 10:23am By: N.Hansen
 Plotted On: May 17, 2019 10:23am By: N.Hansen
 Tighe & Bond: J:\L0700-Lonza Biologics Expansion\15156\F017-G2E Drawings-Figures\AutoCAD\Sheet\0700-017_C-DSGN.dwg



LEGEND

- PROPERTY LINE
- PROPOSED EDGE OF PAVEMENT
- PROPOSED FENCE
- PROPOSED BUILDING
- PROPOSED PAVEMENT SECTION
- PROPOSED CONCRETE PAD
- PROPOSED BOLLARD
- BLDG TYP COORD
- BUILDING TYPICAL COORDINATE

SITE DATA BLOCK

OWNER: PEASE DEVELOPMENT AUTHORITY
55 INTERNATIONAL DRIVE
PORTSMOUTH NH, 03801

APPLICANT/
TENANT: LONZA BIOLOGICS, INC.
101 INTERNATIONAL DRIVE
PORTSMOUTH NH, 03801

LOCATION: 101 INTERNATIONAL DRIVE
PORTSMOUTH NH, 03801
MAP 305 LOT 6

ZONING DISTRICT: AIRPORT BUSINESS AND COMMERCIAL ZONE (ABC)

PROPOSED USES: OFFICE/MANUFACTURING/RESEARCH AND DEVELOPMENT

AREA, YARD, AND HEIGHT REQUIREMENTS	REQUIRED/ALLOWED	PROPOSED/PROVIDED
MINIMUM LOT AREA	5 ACRES	17.1 ACRES
MINIMUM LOT FRONTAGE	200 FEET	1038 FEET
MINIMUM FRONT YARD	70 FEET	118± FEET
MINIMUM SIDE YARD	30 FEET	30± FEET (EXISTING)
MINIMUM REAR YARD	50 FEET	50± FEET (EXISTING)
MAXIMUM BUILDING HEIGHT	FAA CRITERIA	86 FEET
MINIMUM OPEN SPACE	25% OF LOT AREA	34.2%

MINIMUM PARKING REQUIREMENTS
REQUIRED PARKING = 2 SPACES PER 3 EMPLOYEES ON LARGEST SHIFT PLUS ONE SPACE PER COMPANY OWNED VEHICLE

PARKING SUMMARY
LARGEST SHIFT = 740 EMPLOYEES
COMPANY OWNED VEHICLE = 1
PARKING SPACES REQUIRED = 1 + (2/3) X (740) = 493 SPACES
PARKING SPACES PROVIDED = 521 SPACES
HANDICAP ACCESSIBLE SPACES PROVIDED = 11 SPACES

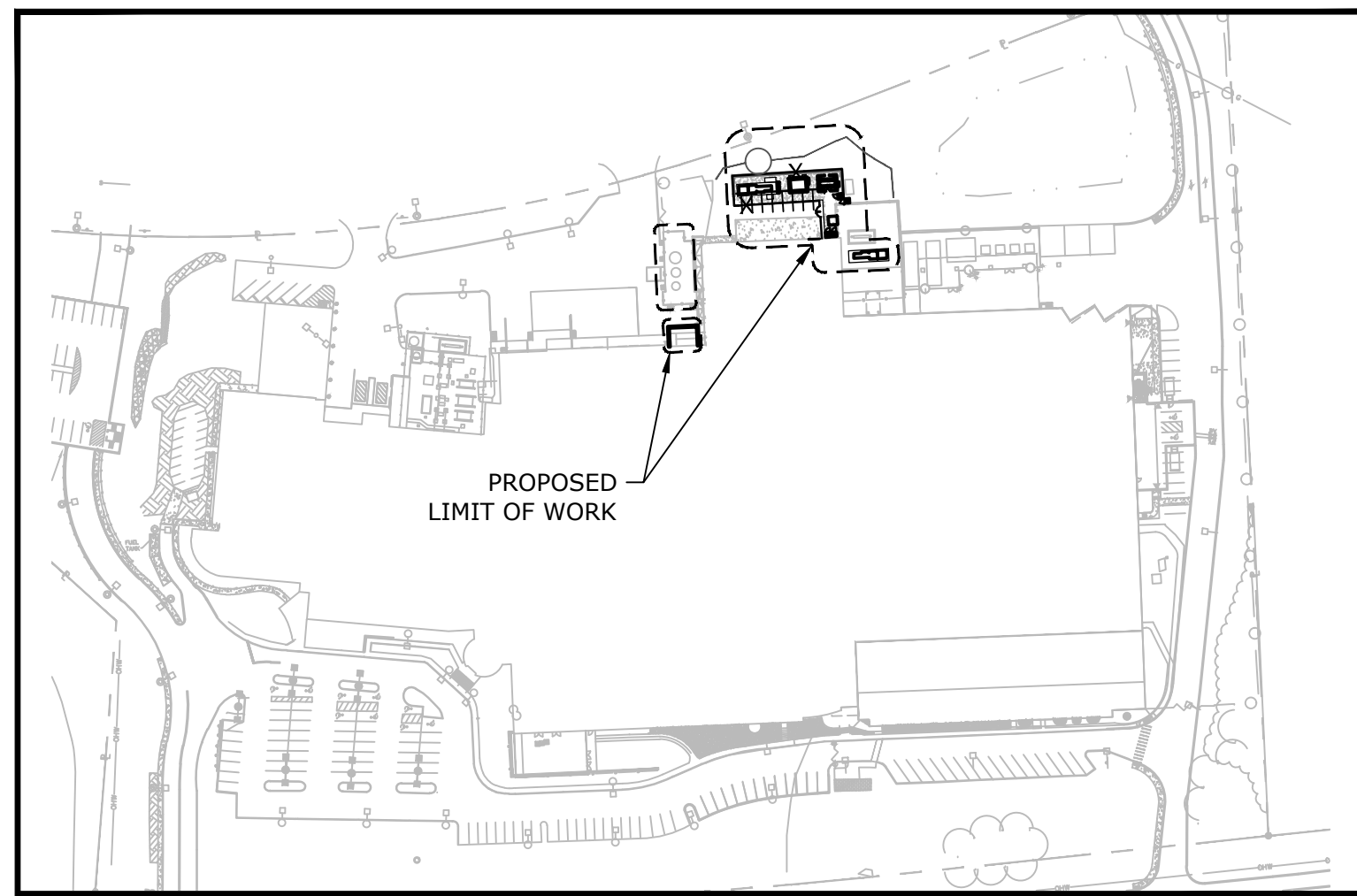
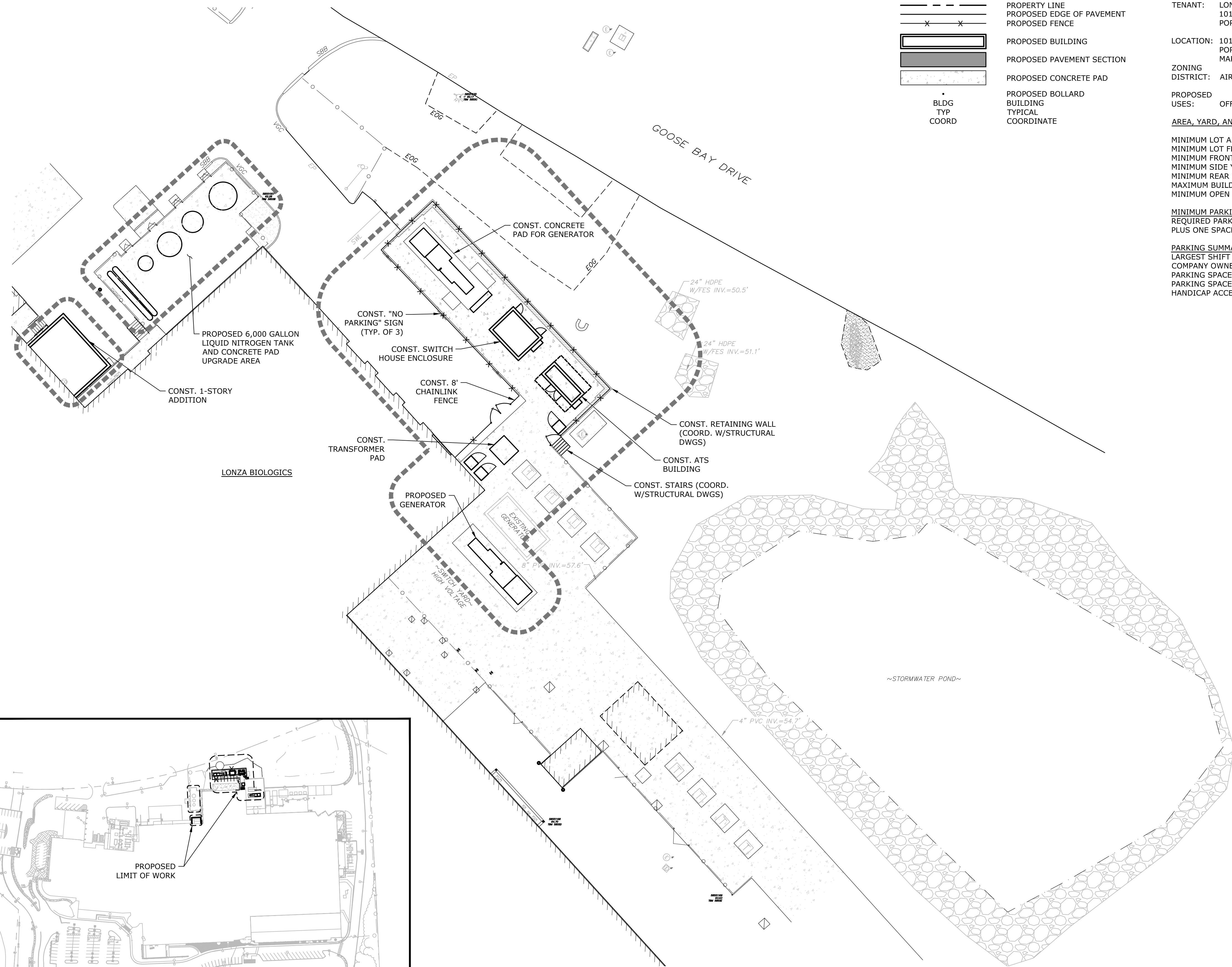
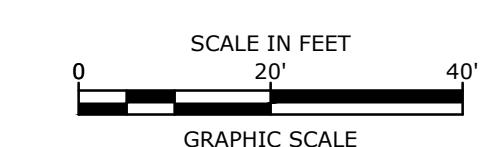
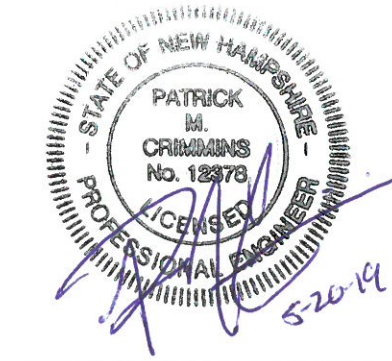
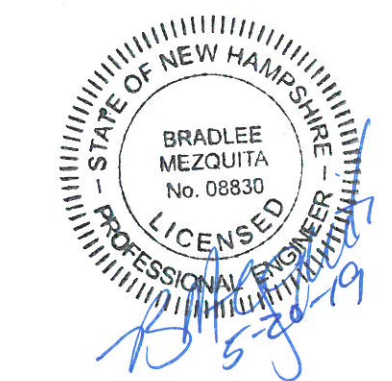

OVERALL SITE PLAN, SCALE 1" = 150'

SITE NOTES:

1. THE CONTRACTOR SHALL EMPLOY A NEW HAMPSHIRE LICENSED LAND SURVEYOR TO DETERMINE ALL LINES AND GRADES.
2. CLEAN AND COAT VERTICAL FACE OF EXISTING PAVEMENT AT SAW CUT LINE WITH RS-1 EMULSION IMMEDIATELY PRIOR TO PLACING NEW BITUMINOUS CONCRETE.
3. ALL MATERIALS AND CONSTRUCTION SHALL CONFORM WITH APPLICABLE FEDERAL, STATE, AND LOCAL CODES & SPECIFICATIONS.
4. COORDINATE ALL WORK WITHIN PUBLIC RIGHT OF WAY WITH THE CITY OF PORTSMOUTH.
5. CONTRACTOR TO SUBMIT AS-BUILT PLANS IN DIGITAL FORMAT (.DWG AND .PDF FILES) ON DISK TO THE OWNER AND ENGINEER UPON COMPLETION OF THE PROJECT. AS-BUILTS SHALL BE PREPARED AND CERTIFIED BY A NEW HAMPSHIRE LICENSED LAND SURVEYOR.
6. SEE ARCHITECTURAL/BUILDING DRAWINGS FOR ALL CONCRETE PADS & SIDEWALKS ADJACENT TO BUILDING.
7. ALL WORK SHALL CONFORM TO THE CITY OF PORTSMOUTH DEPARTMENT OF PUBLIC WORKS, STANDARD SPECIFICATIONS AND WITH THE STATE OF NEW HAMPSHIRE DEPARTMENT OF TRANSPORTATION, "STANDARD SPECIFICATIONS OF ROAD AND BRIDGE CONSTRUCTION", CURRENT EDITION.
8. CONTRACTOR TO PROVIDE BACKFILL AND COMPACTION AT CURB LINE AFTER CONCRETE FORMS FOR SIDEWALKS AND PADS HAVE BEEN STRIPPED. COORDINATE WITH BUILDING CONTRACTOR.
9. COORDINATE ALL WORK ADJACENT TO BUILDING WITH BUILDING CONTRACTOR.
10. CONTRACTOR SHALL BE RESPONSIBLE FOR OBTAINING RETAINING WALL DESIGN FROM STRUCTURAL ENGINEER AND/OR WALL MANUFACTURER. CONTRACTOR SHALL FURNISH ALL LABOR, MATERIALS AND EQUIPMENT REQUIRED TO CONSTRUCT WALL IN ACCORDANCE WITH DESIGN APPROVED BY THE ENGINEER. RETAINING WALL SHALL BE SEGMENTAL BLOCK WALL SYSTEM AS OUTLINED IN THE DETAILS.
11. ALL DIMENSIONS ARE TO THE FACE OF CURB UNLESS OTHERWISE NOTED.
12. ALL CONDITIONS ON THIS PLAN SHALL REMAIN IN EFFECT IN PERPETUITY PURSUANT TO THE REQUIREMENTS OF THE SITE PLAN REVIEW REGULATIONS.

G2E Generator

Lonza Biologics

**Portsmouth,
New Hampshire**

MARK	DATE	DESCRIPTION
E	5/17/2019	TAC Submission
D	5/7/2019	TAC Work Session
C	5/1/2019	BOA Submission
B	4/10/2019	Revised PDA Submission
A	4/8/2019	PDA Submission

PROJECT NO:	L0700-017
DATE:	04/08/2019
FILE:	L0700-017_C-DSGN.dwg
DRAWN BY:	NAH
CHECKED:	PMC
APPROVED:	BLM

SITE PLAN

SCALE:

C-102

LEGEND

- PROPOSED MAJOR CONTOUR LINE
- PROPOSED MINOR CONTOUR LINE
- PROPOSED DRAIN LINE (TYP)
- PROPOSED SILT SOCK
- INLET PROTECTION SILT SACK
- PROPOSED DRAIN MANHOLE
- BUILDING
- TYPICAL COORDINATE
- TOP OF WALL
- BOTTOM OF WALL

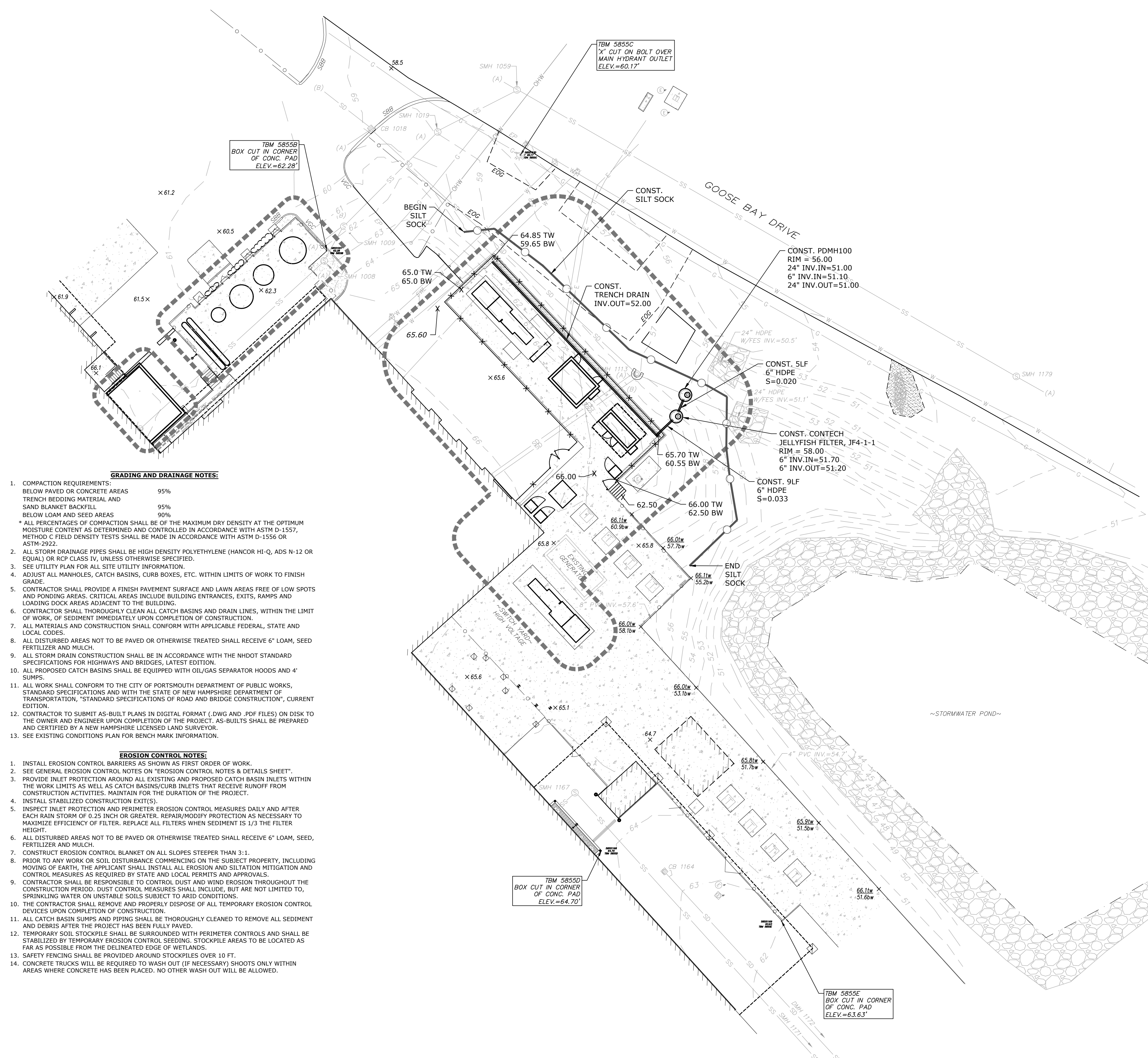
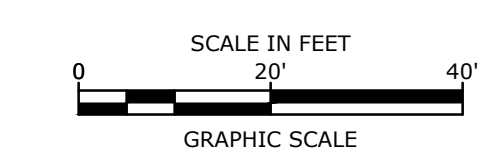
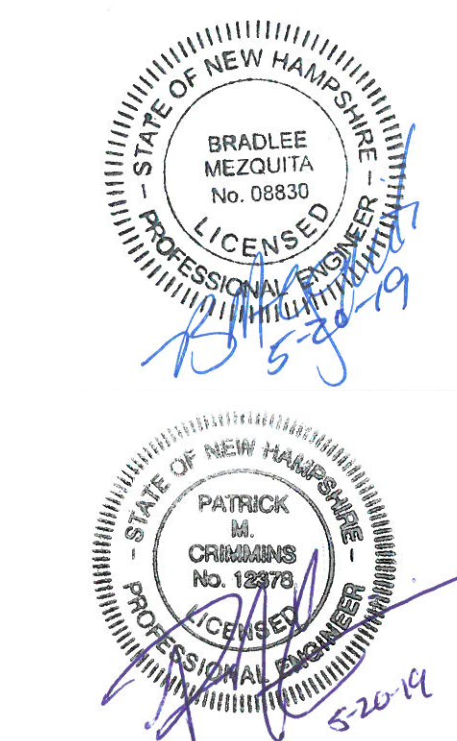

GRADING AND DRAINAGE NOTES:

1. COMPACTION REQUIREMENTS:
BELOW PAVED OR CONCRETE AREAS 95%
TRENCH BEDDING MATERIAL AND SAND BLANKET BACKFILL 95%
BELOW LOAM AND SEED AREAS 90%
* ALL PERCENTAGES OF COMPACTION SHALL BE OF THE MAXIMUM DRY DENSITY AT THE OPTIMUM MOISTURE CONTENT AS DETERMINED AND CONTROLLED IN ACCORDANCE WITH ASTM D-1557, METHOD C FIELD DENSITY TESTS SHALL BE MADE IN ACCORDANCE WITH ASTM D-1556 OR ASTM-2922.
2. ALL STORM DRAINAGE PIPES SHALL BE HIGH DENSITY POLYETHYLENE (HANCOR HI-Q, ADS N-12 OR EQUAL) OR RCP CLASS IV, UNLESS OTHERWISE SPECIFIED.
3. SEE UTILITY PLAN FOR ALL SITE UTILITY INFORMATION.
4. ADJUST ALL MANHOLES, CATCH BASINS, CURB BOXES, ETC. WITHIN LIMITS OF WORK TO FINISH GRADE.
5. CONTRACTOR SHALL PROVIDE A FINISH PAVEMENT SURFACE AND LAWN AREAS FREE OF LOW SPOTS AND PONDING AREAS. CRITICAL AREAS INCLUDE BUILDING ENTRANCES, EXITS, RAMPS AND LOADING DOCK AREAS ADJACENT TO THE BUILDING.
6. CONTRACTOR SHALL THOROUGHLY CLEAN ALL CATCH BASINS AND DRAIN LINES, WITHIN THE LIMIT OF WORK, OF SEDIMENT IMMEDIATELY UPON COMPLETION OF CONSTRUCTION.
7. ALL MATERIALS AND CONSTRUCTION SHALL CONFORM WITH APPLICABLE FEDERAL, STATE AND LOCAL CODES.
8. ALL DISTURBED AREAS NOT TO BE PAVED OR OTHERWISE TREATED SHALL RECEIVE 6" LOAM, SEED FERTILIZER AND MULCH.
9. ALL STORM DRAIN CONSTRUCTION SHALL BE IN ACCORDANCE WITH THE NHDOT STANDARD SPECIFICATIONS FOR HIGHWAYS AND BRIDGES, LATEST EDITION.
10. ALL PROPOSED CATCH BASINS SHALL BE EQUIPPED WITH OIL/GAS SEPARATOR HOODS AND 4' SUMPS.
11. ALL WORK SHALL CONFORM TO THE CITY OF PORTSMOUTH DEPARTMENT OF PUBLIC WORKS, STANDARD SPECIFICATIONS AND WITH THE STATE OF NEW HAMPSHIRE DEPARTMENT OF TRANSPORTATION, "STANDARD SPECIFICATIONS OF ROAD AND BRIDGE CONSTRUCTION", CURRENT EDITION.
12. CONTRACTOR TO SUBMIT AS-BUILT PLANS IN DIGITAL FORMAT (.DWG AND .PDF FILES) ON DISK TO THE OWNER AND ENGINEER UPON COMPLETION OF THE PROJECT. AS-BUILTS SHALL BE PREPARED AND CERTIFIED BY A NEW HAMPSHIRE LICENSED LAND SURVEYOR.
13. SEE EXISTING CONDITIONS PLAN FOR BENCH MARK INFORMATION.

EROSION CONTROL NOTES:

1. INSTALL EROSION CONTROL BARRIERS AS SHOWN AS FIRST ORDER OF WORK.
2. SEE GENERAL EROSION CONTROL NOTES ON "EROSION CONTROL NOTES & DETAILS SHEET".
3. PROVIDE INLET PROTECTION AROUND ALL EXISTING AND PROPOSED CATCH BASIN INLETS WITHIN THE WORK LIMITS AS WELL AS CATCH BASINS/CURB INLETS THAT RECEIVE RUNOFF FROM CONSTRUCTION ACTIVITIES, MAINTAIN FOR THE DURATION OF THE PROJECT.
4. INSTALL STABILIZED CONSTRUCTION EXIT(S).
5. INSPECT INLET PROTECTION AND PERIMETER EROSION CONTROL MEASURES DAILY AND AFTER EACH RAIN STORM OF 0.25 INCH OR GREATER. REPAIR/MODIFY PROTECTION AS NECESSARY TO MAXIMIZE EFFICIENCY OF FILTER. REPLACE ALL FILTERS WHEN SEDIMENT IS 1/3 THE FILTER HEIGHT.
6. ALL DISTURBED AREAS NOT TO BE PAVED OR OTHERWISE TREATED SHALL RECEIVE 6" LOAM, SEED, FERTILIZER AND MULCH.
7. CONSTRUCT EROSION CONTROL BLANKET ON ALL SLOPES STEEPER THAN 3:1.
8. PRIOR TO ANY WORK OR SOIL DISTURBANCE COMMENCING ON THE SUBJECT PROPERTY, INCLUDING MOVING OF EARTH, THE APPLICANT SHALL INSTALL ALL EROSION AND SILTATION MITIGATION AND CONTROL MEASURES AS REQUIRED BY STATE AND LOCAL PERMITS AND APPROVALS.
9. CONTRACTOR SHALL BE RESPONSIBLE TO CONTROL DUST AND WIND EROSION THROUGHOUT THE CONSTRUCTION PERIOD. DUST CONTROL MEASURES SHALL INCLUDE, BUT ARE NOT LIMITED TO, SPRINKLING WATER ON UNSTABLE SOILS SUBJECT TO ARID CONDITIONS.
10. THE CONTRACTOR SHALL REMOVE AND PROPERLY DISPOSE OF ALL TEMPORARY EROSION CONTROL DEVICES UPON COMPLETION OF CONSTRUCTION.
11. ALL CATCH BASIN SUMPS AND PIPING SHALL BE THOROUGHLY CLEANED TO REMOVE ALL SEDIMENT AND DEBRIS AFTER THE PROJECT HAS BEEN FULLY PAVED.
12. TEMPORARY SOIL STOCKPILE SHALL BE SURROUNDED WITH PERIMETER CONTROLS AND SHALL BE STABILIZED BY TEMPORARY EROSION CONTROL SEEDING. STOCKPILE AREAS TO BE LOCATED AS FAR AS POSSIBLE FROM THE DELINEATED EDGE OF WETLANDS.
13. SAFETY FENCING SHALL BE PROVIDED AROUND STOCKPILES OVER 10 FT.
14. CONCRETE TRUCKS WILL BE REQUIRED TO WASH OUT (IF NECESSARY) SHOOTS ONLY WITHIN AREAS WHERE CONCRETE HAS BEEN PLACED. NO OTHER WASH OUT WILL BE ALLOWED.

UTILITY NOTES:

1. THE LOCATIONS OF EXISTING UNDERGROUND UTILITIES ARE APPROXIMATE AND THE LOCATIONS ARE NOT GUARANTEED BY THE OWNER OR ENGINEER. IT IS THE CONTRACTOR'S RESPONSIBILITY TO LOCATE ALL UTILITIES, ANTICIPATE CONFLICTS, REPAIR EXISTING UTILITIES, AND RELOCATE EXISTING UTILITIES REQUIRED TO COMPLETE THE WORK AT NO ADDITIONAL COST TO THE OWNER.
2. COORDINATE ALL UTILITY WORK WITH APPROPRIATE UTILITY COMPANY.
• NATURAL GAS - UNUTIL
• WATER/SEWER - CITY OF PORTSMOUTH
• ELECTRIC - EVERSOURCE
• COMMUNICATIONS - COMCAST/CONSOLIDATED COMMUNICATIONS
3. SEE EXISTING CONDITIONS PLAN FOR BENCHMARK INFORMATION.
4. COORDINATE ALL WORK WITHIN PUBLIC RIGHT OF WAYS WITH THE CITY OF PORTSMOUTH.
5. CONTRACTOR SHALL MAINTAIN UTILITY SERVICES TO ABUTTING PROPERTIES THROUGHOUT CONSTRUCTION.
6. EXISTING UTILITIES TO BE REMOVED SHALL BE CAPPED AT THE MAIN AND MEET THE DEPARTMENT OF PUBLIC WORKS STANDARDS FOR CAPPING OF WATER AND SEWER SERVICES.
7. ALL ELECTRICAL MATERIAL WORKMANSHIP SHALL CONFORM TO THE NATIONAL ELECTRIC CODE, LATEST EDITION, AND ALL APPLICABLE STATE AND LOCAL CODES.
8. THE EXACT LOCATION OF NEW UTILITY SERVICES AND CONNECTIONS SHALL BE COORDINATED WITH THE STRUCTURAL AND ELECTRICAL DRAWINGS AND THE APPLICABLE UTILITY COMPANIES.
9. ADJUST ALL MANHOLES, CATCH BASINS, CURB BOXES, ETC. WITHIN LIMITS OF WORK TO FINISH GRADE.
10. ALL UNDERGROUND CONDUITS SHALL HAVE NYLON PULL ROPES TO FACILITATE PULLING CABLES.
11. THE CONTRACTOR SHALL OBTAIN, PAY FOR, AND COMPLY WITH ALL REQUIRED PERMITS, ARRANGE FOR ALL INSPECTIONS, AND SUBMIT COPIES OF ACCEPTANCE CERTIFICATES TO THE OWNER PRIOR TO THE COMPLETION OF THIS PROJECT.
12. THE CONTRACTOR SHALL PROVIDE AND INSTALL ALL MANHOLES, BOXES, FITTINGS, CONNECTORS, COVER PLATES, AND OTHER MISCELLANEOUS ITEMS NOT NECESSARILY DETAILED ON THESE DRAWINGS TO RENDER INSTALLATION OF UTILITIES COMPLETE AND OPERATIONAL.
13. THE CONTRACTOR SHALL CONTACT "DIG-SAFE" 72 HOURS PRIOR TO COMMENCING CONSTRUCTION. THE CONTRACTOR SHALL HAVE THE "DIG-SAFE" NUMBER ON SITE AT ALL TIMES.
14. CONTRACTOR TO SUBMIT AS-BUILT PLANS ON REPRODUCIBLE MYLARS AND IN DIGITAL FORMAT (.DWG FILES) TO THE OWNER AND ENGINEER UPON COMPLETION OF THE PROJECT. AS-BUILTS SHALL BE PREPARED AND CERTIFIED BY A NEW HAMPSHIRE LICENSED LAND SURVEYOR.
15. SAW CUT AND REMOVE PAVEMENT AND CONSTRUCT PAVEMENT TRENCH PATCH FOR ALL PROPOSED UTILITIES LOCATED IN EXISTING PAVEMENT AREAS TO REMAIN
16. HYDRANTS, GATE VALVES, FITTINGS, ETC. SHALL MEET THE REQUIREMENTS OF THE CITY OF PORTSMOUTH.
17. CONTRACTOR SHALL COORDINATE ALL ELECTRIC WORK INCLUDING BUT NOT LIMITED TO: CONDUIT CONSTRUCTION, MANHOLE CONSTRUCTION, AND TRANSFORMER CONSTRUCTION WITH POWER COMPANY.
18. CONTRACTOR SHALL PHASE UTILITY CONSTRUCTION, PARTICULARLY WATER MAIN AND GAS MAIN CONSTRUCTION AS TO MAINTAIN CONTINUOUS SERVICE TO ABUTTING PROPERTIES. CONTRACTOR SHALL COORDINATE TEMPORARY SERVICES TO ABUTTERS WITH THE UTILITY COMPANY AND AFFECTED ABUTTER.
19. CONTRACTOR SHALL CONSTRUCT ALL UTILITIES AND DRAINS TO WITHIN 10' OF THE FOUNDATION WALLS AND CONNECT THESE TO SERVICE STUBS FROM THE BUILDING.

G2E Generator

Lonza Biologics

Portsmouth, New Hampshire

MARK	DATE	DESCRIPTION
E	5/17/2019	TAC Submission
D	5/7/2019	TAC Work Session
C	5/1/2019	BOA Submission
B	4/10/2019	Revised PDA Submission
A	4/8/2019	PDA Submission

PROJECT NO:	L0700-017
DATE:	04/08/2019
FILE:	L0700-017_C-DSGN.dwg
DRAWN BY:	NAH
CHECKED:	PMC
APPROVED:	BLM

GRADING, DRAINAGE, EROSION CONTROL, & UTILITIES PLAN

SCALE:

Last Saved: 5/17/2019 10:23am By: N.Hansen
 Plotted On: May 17, 2019 10:23am
 Tighe & Bond: J:\L0700\Lonza Biologics Expansion was 15766\017_C-DSGN.dwg

GENERAL PROJECT INFORMATION

PROJECT OWNER: PEASE DEVELOPMENT AUTHORITY
55 INTERNATIONAL DRIVE
PORTSMOUTH, NH 03801
PROJECT APPLICANT: LONZA BIOLOGICS
101 INTERNATIONAL DRIVE
PORTSMOUTH, NH 03801
PROJECT ADDRESS: 101 INTERNATIONAL DRIVE
PORTSMOUTH, NH 03801
PROJECT LATITUDE: 43°-04'-59.0"N
PROJECT LONGITUDE: 71°-48'-09.7"W

PROJECT DESCRIPTION

THE PROPOSED PROJECT IS FOR EXTERIOR IMPROVEMENTS TO SUPPORT ON-GOING IMPROVEMENTS THAT ARE OCCURRING INSIDE THE BUILDING INCLUDING; A 500 SF SINGLE-STORY BUILDING ADDITION IN THE REAR OF 101B, REPLACE AN EXISTING 1,500-GALLON NITROGEN TANK TO NEW 6,000-GALLON NITROGEN TANK AND UPGRADE THE EXISTING CONCRETE PAD AS NEEDED IN THE REAR OF 101B, AND A PROPOSED ELECTRICAL IMPROVEMENTS IN THE REAR OF 101C INCLUDING A TWO (2) NEW GENERATORS WITH 3,312-GALLON DIESEL FUEL ABOVE GROUND STORAGE TANKS (AST), A TRANSFORMER PAD, SWITCHGEAR HOUSED IN AN ENCLOSURE, AUTOMATIC TRANSFER SWITCH HOUSED IN A PROPOSED ENCLOSURE AND AN ASSOCIATED RETAINING WALL.

DISTURBED AREA

THE TOTAL AREA TO BE DISTURBED IS APPROXIMATELY 0.41 ACRES.

SOIL CHARACTERISTICS

BASED ON THE HIGH INTENSITY SOIL SURVEY PREPARED BY GOVE ENVIRONMENTAL SERVICES, INC. IN DECEMBER 2015, THE SITE SOILS VARY FROM WELL DRAINED TO VERY POORLY DRAINED AND PRIMARILY CONSIST OF SOMEWHAT POORLY DRAINED SOILS.

NAME OF RECEIVING WATERS

THE STORM WATER RUNOFF WILL ULTIMATELY DISCHARGE INTO HODGSON BROOK

CONSTRUCTION SEQUENCE OF MAJOR ACTIVITIES:

- 1. CUT AND CLEAR TREES.
- 2. CONSTRUCT TEMPORARY AND PERMANENT SEDIMENT, EROSION AND DETENTION CONTROL FACILITIES. EROSION, SEDIMENT AND DETENTION MEASURES SHALL BE INSTALLED PRIOR TO ANY EARTH MOVING OPERATIONS THAT WILL INFLUENCE STORMWATER RUNOFF SUCH AS:
 - NEW CONSTRUCTION
 - CONTROL OF DUST
 - NEARNESS OF CONSTRUCTION SITE TO RECEIVING WATERS
 - CONSTRUCTION DURING LATE WINTER AND EARLY SPRING
- 3. ALL PERMANENT DITCHES, SWALES, DETENTION, RETENTION AND SEDIMENTATION BASINS TO BE STABILIZED USING THE VEGETATIVE AND NON-STRUCTURAL BMPs PRIOR TO DIRECTING RUNOFF TO THEM.
- 4. CLEAR AND DISPOSE OF DEBRIS.
- 5. CONSTRUCT TEMPORARY CULVERTS AND DIVERSION CHANNELS AS REQUIRED.
- 6. GRADE AND GRAVEL ROADWAYS AND PARKING AREAS - ALL ROADS AND PARKING AREA SHALL BE STABILIZED WITHIN 72 HOURS OF ACHIEVING FINISHED GRADE.
- 7. BEGIN PERMANENT AND TEMPORARY SEEDING AND MULCHING. ALL CUT AND FILL SLOPES SHALL BE SEEDING AND MULCHED WITHIN 72 HOURS OF ACHIEVING FINISHED GRADE.
- 8. DAILY, OR AS REQUIRED, CONSTRUCT TEMPORARY BERMS, DRAINS, DITCHES, PERIMETER EROSION CONTROL MEASURES, SEDIMENT TRAPS, ETC., MULCH AND SEED AS REQUIRED.
- 9. SEDIMENT TRAPS AND/OR BASINS SHALL BE USED AS NECESSARY TO CONTAIN RUNOFF UNTIL SOILS ARE STABILIZED.
- 10. FINISH PAVING ALL ROADWAYS AND PARKING LOTS.
- 11. INSPECT AND MAINTAIN ALL EROSION AND SEDIMENT CONTROL MEASURES.
- 12. COMPLETE PERMANENT SEEDING AND LANDSCAPING.
- 13. REMOVE TRAPPED SEDIMENTS FROM COLLECTOR DEVICES AS APPROPRIATE AND THEN REMOVE TEMPORARY EROSION CONTROL MEASURES.

SPECIAL CONSTRUCTION NOTES:

- 1. THE CONSTRUCTION SEQUENCE MUST LIMIT THE DURATION AND AREA OF DISTURBANCE.
- 2. THE PROJECT IS TO BE MANAGED IN A MANNER THAT MEETS THE REQUIREMENTS AND INTENT OF RSA 430:53 AND CHAPTER AGR 3800 RELATIVE TO INVASIVE SPECIES.

EROSION CONTROL NOTES:

- 1. ALL EROSION CONTROL MEASURES AND PRACTICES SHALL CONFORM TO THE "NEW HAMPSHIRE STORMWATER MANUAL VOLUME 3: EROSION AND SEDIMENT CONTROLS DURING CONSTRUCTION" PREPARED BY THE NHDES.
- 2. PRIOR TO ANY WORK OR SOIL DISTURBANCE, CONTRACTOR SHALL SUBMIT SHOP DRAWINGS FOR EROSION CONTROL MEASURES AS REQUIRED IN THE PROJECT MANUAL.
- 3. CONTRACTOR SHALL INSTALL TEMPORARY EROSION CONTROL BARRIERS, INCLUDING HAY BALES, SILT FENCES, MULCH BERMS, SILT SOCKS AND SILT SOCKS AS SHOWN IN THESE DRAWINGS AS THE FIRST ORDER OF WORK.
- 4. SILT SACK INLET PROTECTION SHALL BE INSTALLED IN ALL EXISTING AND PROPOSED CATCH BASIN INLETS WITHIN THE WORK LIMITS AND BE MAINTAINED FOR THE DURATION OF THE PROJECT.
- 5. PERIMETER CONTROLS INCLUDING SILT FENCES, MULCH BERM, SILT SOCK, AND/OR HAY BALE BARRIERS SHALL BE MAINTAINED FOR THE DURATION OF THE PROJECT UNTIL NON-PAVED AREAS HAVE BEEN STABILIZED.
- 6. THE CONTRACTOR SHALL REMOVE AND PROPERLY DISPOSE OF ALL TEMPORARY EROSION CONTROL DEVICES UPON COMPLETION OF CONSTRUCTION.
- 7. ALL DISTURBED AREAS NOT OTHERWISE BEING TREATED SHALL RECEIVE 6" LOAM, SEED AND FERTILIZER.
- 8. INSPECT ALL INLET PROTECTION AND PERIMETER CONTROLS WEEKLY AND AFTER EACH RAIN STORM OF 0.25 INCH OR GREATER. REPAIR/MODIFY PROTECTION AS NECESSARY TO MAXIMIZE EFFICIENCY OF FILTER. REPLACE ALL FILTERS WHEN SEDIMENT IS 1/3 THE FILTER HEIGHT.
- 9. CONSTRUCT EROSION CONTROL BLANKETS ON ALL SLOPES STEEPER THAN 3:1.

STABILIZATION:

- 1. AN AREA SHALL BE CONSIDERED STABLE WHEN ONE OF THE FOLLOWING HAS OCCURRED:
 - A. BASE COURSE GRAVELS HAVE BEEN INSTALLED IN AREAS TO BE PAVED;
 - B. A MINIMUM OF 85% VEGETATED GROWTH HAS BEEN ESTABLISHED;
 - C. A MINIMUM OF 3" OF NON-EROSIVE MATERIAL SUCH AS STONE OR RIPRAP HAS BEEN INSTALLED;
 - D. EROSION CONTROL BLANKETS HAVE BEEN PROPERLY INSTALLED.;
 - E. IN AREAS TO BE PAVED, "STABLE" MEANS THAT BASE COURSE GRAVELS MEETING THE REQUIREMENTS OF NHDOT STANDARD FOR ROAD AND BRIDGE CONSTRUCTION, 2016, ITEM 304.2 HAVE BEEN INSTALLED.
- 2. WINTER STABILIZATION PRACTICES:
 - A. ALL PROPOSED VEGETATED AREAS THAT DO NOT EXHIBIT A MINIMUM OF 85 PERCENT VEGETATIVE GROWTH BY OCTOBER 15, OR WHICH ARE DISTURBED AFTER OCTOBER 15, SHALL BE STABILIZED BY SEEDING AND INSTALLING EROSION CONTROL BLANKETS ON SLOPES GREATER THAN 3:1, AND SEEDING AND PLACING 3 TO 4 TONS OF MULCH PER ACRE, SECURED WITH ANCHORED NETTING, ELSEWHERE. THE INSTALLATION OF EROSION CONTROL BLANKETS OR MULCH AND NETTING SHALL NOT OCCUR OVER ACCUMULATED SNOW OR ON FROZEN GROUND AND SHALL BE COMPLETED IN ADVANCE OF THAW OR SPRING MELT EVENTS;
 - B. ALL DITCHES OR SWALES WHICH DO NOT EXHIBIT A MINIMUM OF 85 PERCENT VEGETATIVE GROWTH BY OCTOBER 15, OR WHICH ARE DISTURBED AFTER OCTOBER 15, SHALL BE STABILIZED TEMPORARILY WITH STONE OR EROSION CONTROL BLANKETS APPROPRIATE FOR THE DESIGN FLOW CONDITIONS;
 - C. AFTER NOVEMBER 15, INCOMPLETE ROAD OR PARKING SURFACES, WHERE WORK HAS STOPPED FOR THE WINTER SEASON, SHALL BE PROTECTED WITH A MINIMUM OF 3 INCHES OF CRUSHED GRAVEL PER NHDOT ITEM 304.3, OR IF CONSTRUCTION IS TO CONTINUE THROUGH THE WINTER SEASON BE CLEARED OF ANY ACCUMULATED SNOW AFTER EACH STORM EVENT;

- 3. STABILIZATION SHALL BE INITIATED ON ALL LOAM STOCKPILES, AND DISTURBED AREAS, WHERE CONSTRUCTION ACTIVITY SHALL NOT OCCUR FOR MORE THAN TWENTY-ONE (21) CALENDAR DAYS BY THE FOURTEENTH (14TH) DAY AFTER CONSTRUCTION ACTIVITY HAS PERMANENTLY OR TEMPORARILY CEASED IN THAT AREA. STABILIZATION MEASURES TO BE USED INCLUDE:
 - A. TEMPORARY SEEDING;
 - B. MULCHING.
- 4. ALL AREAS SHALL BE STABILIZED WITHIN 45 DAYS OF INITIAL DISTURBANCE.
- 5. WHEN CONSTRUCTION ACTIVITY PERMANENTLY OR TEMPORARILY CEASES WITHIN 100 FEET OF NEARBY SURFACE WATERS OR DELINEATED WETLANDS, THE AREA SHALL BE STABILIZED WITHIN SEVEN (7) DAYS OR PRIOR TO A RAIN EVENT. ONCE CONSTRUCTION ACTIVITY CEASES PERMANENTLY IN AN THESE AREAS, SILT FENCES, MULCH BERMS, HAY BALE BARRIERS AND ANY EARTH/DIKES SHALL BE REMOVED ONCE PERMANENT MEASURES ARE ESTABLISHED.
- 6. DURING CONSTRUCTION, RUNOFF WILL BE DIVERTED AROUND THE SITE WITH EARTH DIKES, PIPING OR STABILIZED CHANNELS WHERE POSSIBLE. SHEET RUNOFF FROM THE SITE WILL BE FILTERED THROUGH SILT FENCES, MULCH BERMS, HAY BALE BARRIERS, OR SILT SOCKS. ALL STORM DRAIN BASIN INLETS SHALL BE PROVIDED WITH FLARED END SECTIONS AND TRASH RACKS. THE SITE SHALL BE STABILIZED FOR THE WINTER BY NOVEMBER 15.

DUST CONTROL:

- 1. THE CONTRACTOR SHALL BE RESPONSIBLE TO CONTROL DUST THROUGHOUT THE CONSTRUCTION PERIOD.
- 2. DUST CONTROL METHODS SHALL INCLUDE, BUT BE NOT LIMITED TO SPRINKLING WATER ON EXPOSED AREAS, COVERING LOADED DUMP TRUCKS LEAVING THE SITE, AND TEMPORARY MULCHING.
- 3. DUST CONTROL MEASURES SHALL BE UTILIZED SO AS TO PREVENT THE MIGRATION OF DUST FROM THE SITE TO ABUTTING AREAS.

STOCKPILES:

- 1. LOCATE STOCKPILES A MINIMUM OF 50 FEET AWAY FROM CATCH BASINS, SWALES, AND CULVERTS.
- 2. ALL STOCKPILES SHOULD BE SURROUNDED WITH TEMPORARY EROSION CONTROL MEASURES PRIOR TO THE ONSET OF PRECIPITATION.
- 3. PERIMETER BARRIERS SHOULD BE MAINTAINED AT ALL TIMES, AND ADJUSTED AS NEEDED TO ACCOMMODATE THE DELIVERY AND REMOVAL OF MATERIALS FROM THE STOCKPILE. THE INTEGRITY OF THE BARRIER SHOULD BE INSPECTED AT THE END OF EACH WORKING DAY.
- 4. TRAP ALL STOCKPILES FROM STORMWATER RUN-OFF USING TEMPORARY EROSION CONTROL MEASURES SUCH AS BERMS, SILT SOCK, OR OTHER APPROVED PRACTICE TO PREVENT MIGRATION OF MATERIAL BEYOND THE IMMEDIATE CONFINES OF THE STOCKPILES.

OFF SITE VEHICLE TRACKING:

- 1. THE CONTRACTOR SHALL CONSTRUCT STABILIZED CONSTRUCTION ENTRANCE(S) PRIOR TO ANY EXCAVATION ACTIVITIES.

VEGETATION:

- 1. TEMPORARY GRASS COVER:
 - A. SEEDBED PREPARATION:
 - a. APPLY FERTILIZER AT THE RATE OF 600 POUNDS PER ACRE OF 10-10-10. APPLY LIMESTONE (EQUIVALENT TO 50 PERCENT CALCIUM PLUS MAGNESIUM OXIDE) AT A RATE OF THREE (3) TONS PER ACRE;
 - B. SEEDING:
 - a. UTILIZE ANNUAL RYE GRASS AT A RATE OF 40 LBS/ACRE;
 - b. WHERE THE SOIL HAS BEEN COMPACTED BY CONSTRUCTION OPERATIONS, LOOSEN SOIL TO A DEPTH OF TWO (2) INCHES BEFORE APPLYING FERTILIZER, LIME AND SEED;
 - c. APPLY SEED UNIFORMLY BY HAND, CYCLONE SEEDER, OR HYDROSEEDER (SLURRY INCLUDING SEED AND FERTILIZER, HYDROSEEDINGS, WHICH INCLUDE MULCH, MAY BE LEFT ON SOIL SURFACE. SEEDING RATES MUST BE INCREASED 10% WHEN HYDROSEEDING;
 - C. MAINTENANCE:
 - a. TEMPORARY SEEDING SHALL BE PERIODICALLY INSPECTED. AT A MINIMUM, 95% OF THE SOIL SURFACE SHOULD BE COVERED BY VEGETATION. IF ANY EVIDENCE OF EROSION OR SEDIMENTATION IS APPARENT, REPAIRS SHALL BE MADE AND OTHER TEMPORARY MEASURES USED IN THE INTERIM (MULCH, FILTER BARRIERS, CHECK DAMS, ETC.).
- 2. VEGETATIVE PRACTICE:
 - A. FOR PERMANENT MEASURES AND PLANTINGS:
 - a. LIMESTONE SHALL BE THOROUGHLY INCORPORATED INTO THE LOAM LAYER AT A RATE OF THREE (3) TONS PER ACRE IN ORDER TO PROVIDE A PH VALUE OF 5.5 TO 6.5;
 - b. FERTILIZER SHALL BE SPREAD ON THE TOP LAYER OF LOAM AND WORKED INTO THE SURFACE. FERTILIZER APPLICATION RATE SHALL BE 800 POUNDS PER ACRE OF 10-20-20 FERTILIZER;
 - c. SOIL CONDITIONERS AND FERTILIZER SHALL BE APPLIED AT THE RECOMMENDED RATES AND SHALL BE THOROUGHLY WORKED INTO THE LOAM. LOAM SHALL BE RAKED UNTIL THE SURFACE IS FINELY PULVERIZED, SMOOTH AND EVEN, AND THEN COMPACTED TO AN EVEN SURFACE CONFORMING TO THE REQUIRED LINES AND GRADES WITH APPROVED ROLLERS WEIGHING BETWEEN 4-1/2 POUNDS AND 5-1/2 POUNDS PER INCH OF WIDTH;
 - d. SEED SHALL BE SOWN AT THE RATE SHOWN BELOW. SOWING SHALL BE DONE ON A CALM, DRY DAY, PREFERABLY BY MACHINE, BUT IF BY HAND, ONLY BY EXPERIENCED WORKMEN. IMMEDIATELY BEFORE SEEDING, THE SOIL SHALL BE LIGHTLY RAKED. ONE HALF THE SEED SHALL BE SOWN IN ONE DIRECTION AND THE OTHER HALF AT RIGHT ANGLES TO THE ORIGINAL DIRECTION. IT SHALL BE LIGHTLY RAKED INTO THE SOIL TO A DEPTH NOT OVER 1/4 INCH AND ROLLED WITH A HAND ROLLER WEIGHING NOT OVER 100 POUNDS PER LINEAR FOOT OF WIDTH;
 - e. HAY MULCH SHALL BE APPLIED IMMEDIATELY AFTER SEEDING AS INDICATED ABOVE;
 - f. THE SURFACE SHALL BE WATERED AND KEPT MOIST WITH A FINE SPRAY AS REQUIRED, WITHOUT WASHING AWAY THE SOIL, UNTIL THE GRASS IS WELL ESTABLISHED. ANY AREAS WHICH ARE NOT SATISFACTORILY COVERED WITH GRASS SHALL BE RESEED, AND ALL NOXIOUS WEEDS REMOVED;
 - g. THE CONTRACTOR SHALL PROTECT AND MAINTAIN THE SEEDED AREAS UNTIL ACCEPTED;
 - h. A GRASS SEED MIXTURE CONTAINING THE FOLLOWING SEED REQUIREMENTS SHALL BE APPLIED AT THE INDICATED RATE:

SEED MIX	APPLICATION RATE
CREeping RED FESCUE	20 LBS/ACRE
TALL FESCUE	20 LBS/ACRE
REDTOP	2 LBS/ACRE

IN NO CASE SHALL THE WEED CONTENT EXCEED ONE (1) PERCENT BY WEIGHT. ALL SEED SHALL COMPLY WITH STATE AND FEDERAL SEED LAWS. SEEDING SHALL BE DONE NO LATER THAN SEPTEMBER 15. IN NO CASE SHALL SEEDING TAKE PLACE OVER SNOW.
 - B. DORMANT SEEDING (SEPTEMBER 15 TO FIRST SNOWFALL):
 - A. FOLLOW PERMANENT MEASURES SLOPE, LIME, FERTILIZER AND GRADING REQUIREMENTS. APPLY SEED MIXTURE AT TWICE THE INDICATED RATE. APPLY MULCH AS INDICATED FOR PERMANENT MEASURES.

CONCRETE WASHOUT AREA:

- 1. THE FOLLOWING ARE THE ONLY NON-STORMWATER DISCHARGES ALLOWED. ALL OTHER NON-STORMWATER DISCHARGES ARE PROHIBITED ON SITE:
 - A. THE CONCRETE DELIVERY TRUCKS SHALL, WHENEVER POSSIBLE, USE WASHOUT FACILITIES AT THEIR OWN PLANT OR DISPATCH FACILITY;
 - B. IF IT IS NECESSARY, SITE CONTRACTOR SHALL DESIGNATE SPECIFIC WASHOUT AREAS AND DESIGN FACILITIES TO HANDLE ANTICIPATED WASHOUT WATER;
 - C. CONTRACTOR SHALL LOCATE WASHOUT AREAS AT LEAST 150 FEET AWAY FROM STORM DRAINS, SWALES AND SURFACE WATERS OR DELINEATED WETLANDS;
 - D. INSPECT WASHOUT FACILITIES DAILY TO DETECT LEAKS OR TEARS AND TO IDENTIFY WHEN MATERIALS NEED TO BE REMOVED.

ALLOWABLE NON-STORMWATER DISCHARGES:

- 1. FIRE-FIGHTING ACTIVITIES;
- 2. FIRE HYDRANT FLUSHING;
- 3. WATERS USED TO WASH VEHICLES WHERE DETERGENTS ARE NOT USED;
- 4. WATER USED TO CONTROL DUST;

- 5. POTABLE WATER INCLUDING UNCONTAMINATED WATER LINE FLUSHING;
- 6. ROUTINE EXTERNAL BUILDING WASH DOWN WHERE DETERGENTS ARE NOT USED;
- 7. PAVEMENT WASH WATERS WHERE DETERGENTS ARE NOT USED;
- 8. UNCONTAMINATED AIR CONDITIONING/COMPRESSOR CONDENSATION;
- 9. UNCONTAMINATED GROUND WATER OR SPRING WATER;
- 10. FOUNDATION OR FOOTING DRAINS WHICH ARE UNCONTAMINATED;
- 11. UNCONTAMINATED EXCAVATION DEWATERING;
- 12. LANDSCAPE IRRIGATION.

WASTE DISPOSAL:

- 1. WASTE MATERIAL:
 - A. ALL WASTE MATERIALS SHALL BE COLLECTED AND STORED IN SECURELY LIDDED RECEPTACLES. ALL TRASH AND CONSTRUCTION DEBRIS FROM THE SITE SHALL BE DEPOSITED IN A DUMPSTER;
 - B. NO CONSTRUCTION WASTE MATERIALS SHALL BE BURIED ON SITE;
 - C. ALL PERSONNEL SHALL BE INSTRUCTED REGARDING THE CORRECT PROCEDURE FOR WASTE DISPOSAL BY THE SUPERINTENDENT.
- 2. HAZARDOUS WASTE:
 - A. ALL HAZARDOUS WASTE MATERIALS SHALL BE DISPOSED OF IN THE MANNER SPECIFIED BY LOCAL OR STATE REGULATION OR BY THE MANUFACTURER;
 - B. SITE PERSONNEL SHALL BE INSTRUCTED IN THESE PRACTICES BY THE SUPERINTENDENT.
- 3. SANITARY WASTE:
 - A. ALL SANITARY WASTE SHALL BE COLLECTED FROM THE PORTABLE UNITS A MINIMUM OF ONCE PER WEEK BY A LICENSED SANITARY WASTE MANAGEMENT CONTRACTOR.

SPILL PREVENTION:

- 1. CONTRACTOR SHALL BE FAMILIAR WITH SPILL PREVENTION MEASURES REQUIRED BY LOCAL, STATE AND FEDERAL AGENCIES. AT A MINIMUM, CONTRACTOR SHALL FOLLOW THE BEST MANAGEMENT SPILL PREVENTION PRACTICES OUTLINED BELOW.
- 2. THE FOLLOWING ARE THE MATERIAL MANAGEMENT PRACTICES THAT SHALL BE USED TO REDUCE THE RISK OF SPILLS OR OTHER ACCIDENTAL EXPOSURE OF MATERIALS AND SUBSTANCES DURING CONSTRUCTION TO STORMWATER RUNOFF:
 - A. GOOD HOUSEKEEPING - THE FOLLOWING GOOD HOUSEKEEPING PRACTICE SHALL BE FOLLOWED ON SITE DURING CONSTRUCTION:
 - a. ONLY SUFFICIENT AMOUNTS OF PRODUCTS TO DO THE JOB SHALL BE STORED ON SITE;
 - b. ALL MATERIALS STORED ON SITE SHALL BE STORED IN A NEAT, ORDERLY MANNER IN THEIR PROPER (ORIGINAL IF POSSIBLE) CONTAINERS AND, IF POSSIBLE, UNDER A ROOF OR OTHER ENCLOSURE;
 - c. MANUFACTURER'S RECOMMENDATIONS FOR PROPER USE AND DISPOSAL SHALL BE FOLLOWED;
 - d. THE SITE SUPERINTENDENT SHALL INSPECT DAILY TO ENSURE PROPER USE AND DISPOSAL OF MATERIALS;
 - e. SUBSTANCES SHALL NOT BE MIXED WITH ONE ANOTHER UNLESS RECOMMENDED BY THE MANUFACTURER;
 - f. WHENEVER POSSIBLE ALL OF A PRODUCT SHALL BE USED UP BEFORE DISPOSING OF THE CONTAINER.
 - B. HAZARDOUS PRODUCTS - THE FOLLOWING PRACTICES SHALL BE USED TO REDUCE THE RISKS ASSOCIATED WITH HAZARDOUS MATERIALS:
 - a. PRODUCTS SHALL BE KEPT IN THEIR ORIGINAL CONTAINERS UNLESS THEY ARE NOT RESEALABLE;
 - b. ORIGINAL LABELS AND MATERIAL SAFETY DATA SHALL BE RETAINED FOR IMPORTANT PRODUCT INFORMATION;
 - c. SURPLUS PRODUCT THAT MUST BE DISPOSED OF SHALL BE DISCARDED ACCORDING TO THE MANUFACTURER'S RECOMMENDED METHODS OF DISPOSAL.
 - C. PRODUCT SPECIFIC PRACTICES - THE FOLLOWING PRODUCT SPECIFIC PRACTICES SHALL BE FOLLOWED ON SITE:
 - a. PETROLEUM PRODUCTS:
 - ALL ON SITE VEHICLES SHALL BE MONITORED FOR LEAKS AND RECEIVE REGULAR PREVENTIVE MAINTENANCE TO REDUCE LEAKAGE;
 - PETROLEUM PRODUCTS SHALL BE STORED IN TIGHTLY SEALED CONTAINERS WHICH ARE CLEARLY LABELED. ANY ASPHALT BASED SUBSTANCES USED ON SITE SHALL BE APPLIED ACCORDING TO THE MANUFACTURER'S RECOMMENDATIONS.
 - b. FERTILIZERS:
 - FERTILIZERS USED SHALL BE APPLIED ONLY IN THE MINIMUM AMOUNTS DIRECTED BY THE SPECIFICATIONS;
 - ONCE APPLIED FERTILIZER SHALL BE WORKED INTO THE SOIL TO LIMIT EXPOSURE TO STORMWATER;
 - STORAGE SHALL BE IN A COVERED SHED OR ENCLOSED TRAILERS. THE CONTENTS OF ANY PARTIALLY USED BAGS OF FERTILIZER SHALL BE TRANSFERRED TO A SEALABLE PLASTIC BIN TO AVOID SPILLS.
 - c. PAINTS:
 - ALL CONTAINERS SHALL BE TIGHTLY SEALED AND STORED WHEN NOT REQUIRED FOR USE;
 - EXCESS PAINT SHALL NOT BE DISCHARGED TO THE STORM SEWER SYSTEM;
 - EXCESS PAINT SHALL BE DISPOSED OF PROPERLY ACCORDING TO MANUFACTURER'S INSTRUCTIONS OR STATE AND LOCAL REGULATIONS.
 - D. SPILL CONTROL PRACTICES - IN ADDITION TO GOOD HOUSEKEEPING AND MATERIAL MANAGEMENT PRACTICES DISCUSSED IN THE PREVIOUS SECTION, THE FOLLOWING PRACTICES SHALL BE FOLLOWED FOR SPILL PREVENTION AND CLEANUP:
 - a. MANUFACTURER'S RECOMMENDED METHODS FOR SPILL CLEANUP SHALL BE CLEARLY POSTED AND SITE PERSONNEL SHALL BE MADE AWARE OF THE PROCEDURES AND THE LOCATION OF THE INFORMATION AND CLEANUP SUPPLIES;
 - b. MATERIALS AND EQUIPMENT NECESSARY FOR SPILL CLEANUP SHALL BE KEPT IN THE MATERIAL STORAGE AREA ON SITE. EQUIPMENT AND MATERIALS SHALL INCLUDE BUT NOT BE LIMITED TO BROOMS, DUSTPANS, MOPS, RAGS, GLOVES, GOGGLES, KITTY LITTER, SAND, SAWDUST AND PLASTIC OR METAL TRASH CONTAINERS SPECIFICALLY FOR THIS PURPOSE;
 - c. ALL SPILLS SHALL BE CLEANED UP IMMEDIATELY AFTER DISCOVERY;
 - d. THE SPILL AREA SHALL BE KEPT WELL VENTILATED AND PERSONNEL SHALL WEAR APPROPRIATE PROTECTIVE CLOTHING TO PREVENT INJURY FROM CONTACT WITH A HAZARDOUS SUBSTANCE;
 - e. SPILLS OF TOXIC OR HAZARDOUS MATERIAL SHALL BE REPORTED TO THE APPROPRIATE LOCAL, STATE OR FEDERAL AGENCIES AS REQUIRED;
 - f. THE SITE SUPERINTENDENT RESPONSIBLE FOR DAY-TO-DAY SITE OPERATIONS SHALL BE THE SPILL PREVENTION AND CLEANUP COORDINATOR.

- E. VEHICLE FUELING AND MAINTENANCE PRACTICE:
 - a. CONTRACTOR SHALL MAKE AN EFFORT TO PERFORM EQUIPMENT/VEHICAL FUELING AND MAINTENANCE AT AN OFF-SITE FACILITY;
 - b. CONTRACTOR SHALL PROVIDE AN ON-SITE FUELING AND MAINTENANCE AREA THAT IS CLEAN AND DRY;
 - c. IF POSSIBLE THE CONTRACTOR SHALL KEEP AREA COVERED;
 - d. CONTRACTOR SHALL KEEP A SPILL KIT AT THE FUELING AND MAINTENANCE AREA;
 - e. CONTRACTOR SHALL REGULARLY INSPECT VEHICLES FOR LEAKS AND DAMAGE;
 - f. CONTRACTOR SHALL USE DRIP PANS, DRIP CLOTHS, OR ABSORBENT PADS WHEN REPLACING SPENT FLUID.

EROSION CONTROL OBSERVATIONS AND MAINTENANCE PRACTICES

- THE FOLLOWING REPRESENTS THE GENERAL OBSERVATION AND REPORTING PRACTICES THAT SHALL BE FOLLOWED AS PART OF THIS PROJECT:
 - 1. OBSERVATIONS OF THE PROJECT SHALL BE MADE BY THE CONTRACTOR AT LEAST ONCE A WEEK OR WITHIN 24 HOURS OF A STORM 0.25 INCHES OR GREATER;
 - 2. AN OBSERVATION REPORT SHALL BE MADE AFTER EACH OBSERVATION AND DISTRIBUTED TO THE ENGINEER, THE OWNER, AND THE CONTRACTOR;
 - 3. A REPRESENTATIVE OF THE SITE CONTRACTOR, SHALL BE RESPONSIBLE FOR MAINTENANCE AND REPAIR ACTIVITIES;
 - 4. IF A REPAIR IS NECESSARY, IT SHALL BE INITIATED WITHIN 24 HOURS OF REPORT.

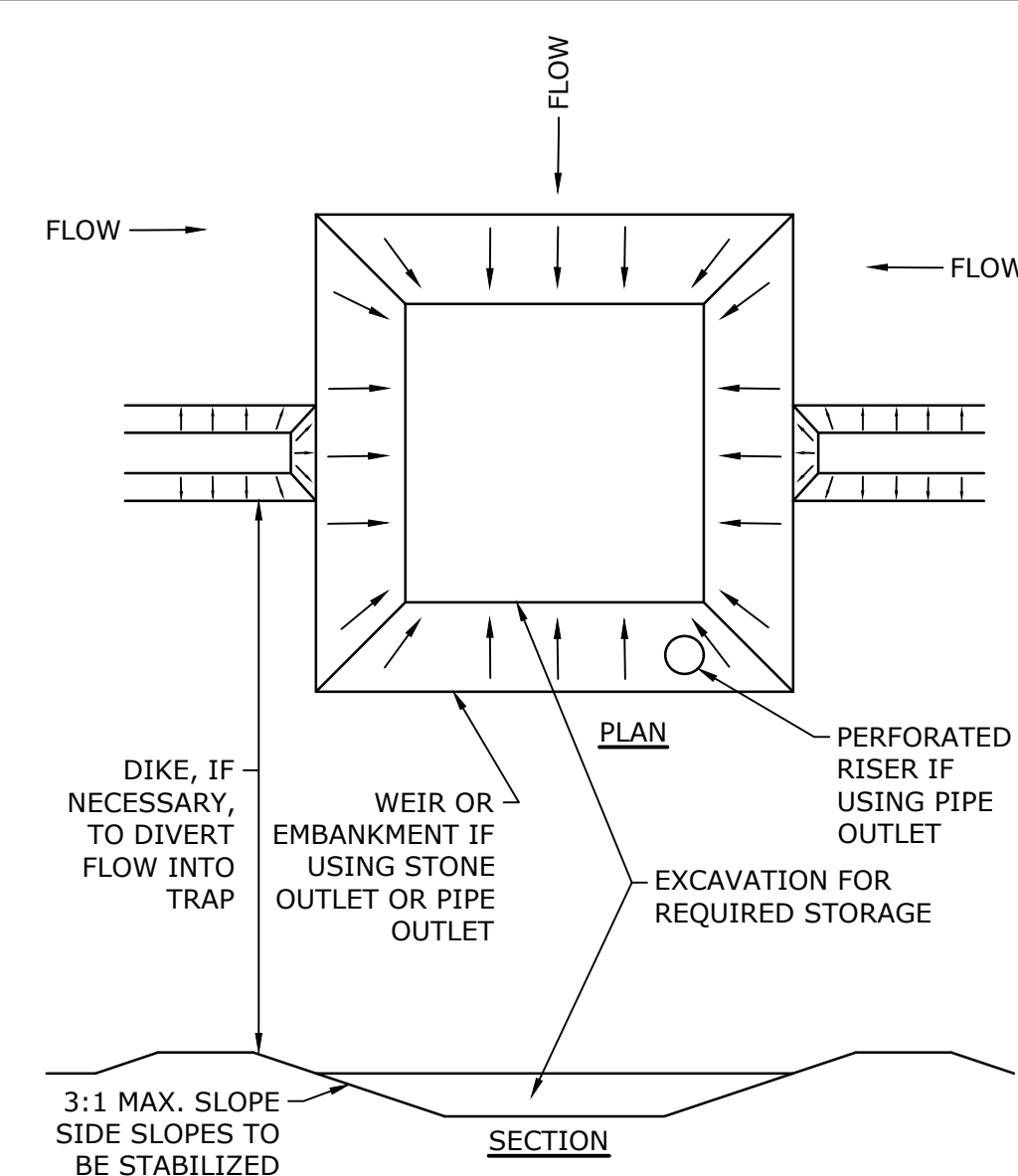

NOTES:

- 1. THE TRAP SHALL BE INSTALLED AS CLOSE TO THE DISTURBED AREA AS POSSIBLE.
- 2. THE MAXIMUM CONTRIBUTING AREA TO A SINGLE TRAP SHALL BE LESS THAN 5 ACRES.
- 3. THE MINIMUM VOLUME OF THE TRAP SHALL BE 3,600 CUBIC FEET OF STORAGE FOR EACH ACRE OF DRAINAGE AREA.
- 4. TRAP OUTLET SHALL BE MINIMUM OF ONE FOOT BELOW THE CREST OF THE TRAP.
- 5. TRAP SHALL DISCHARGE TO A STABILIZED AREA.
- 6. TRAP SHALL BE CLEANED WHEN 50 PERCENT OF THE ORIGINAL VOLUME IS FILLED.
- 7. MATERIALS REMOVED FROM THE TRAP SHALL BE PROPERLY DISPOSED OF AND STABILIZED.

SEDIMENT TRAP

NO SCALE

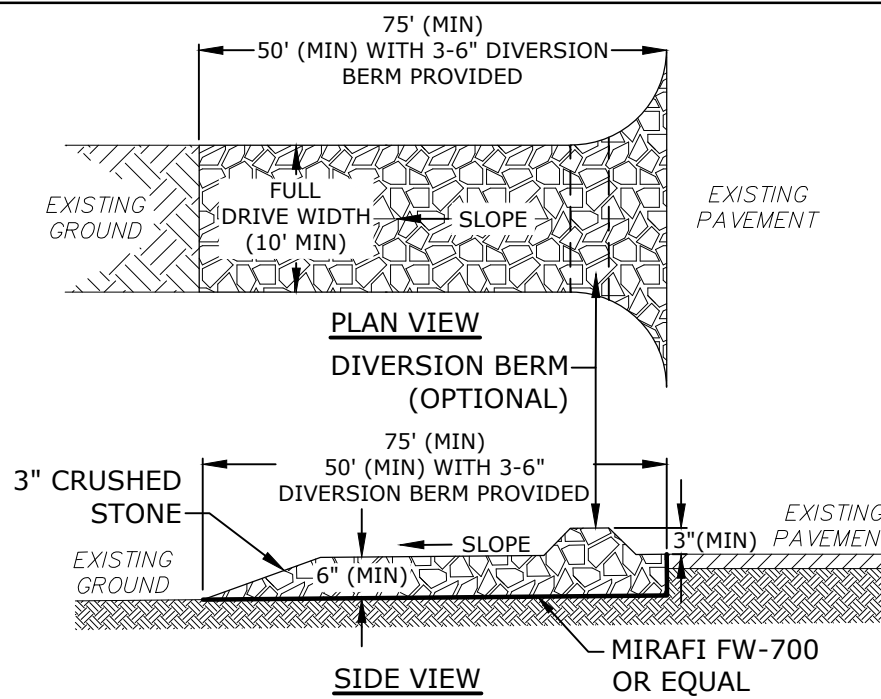

NOTES:

- 1. THE ENTRANCE SHALL BE MAINTAINED IN A CONDITION WHICH WILL PREVENT TRACKING OF SEDIMENT FROM THE SITE. WHEN WASHING IS REQUIRED, IT SHALL BE DONE SO RUNOFF DRAINS INTO AN APPROVED SEDIMENT TRAPPING DEVICE. ALL SEDIMENT SHALL BE PREVENTED FROM ENTERING STORM DRAINS, DITCHES, OR WATERWAYS

STABILIZED CONSTRUCTION ENTRANCE

NO SCALE

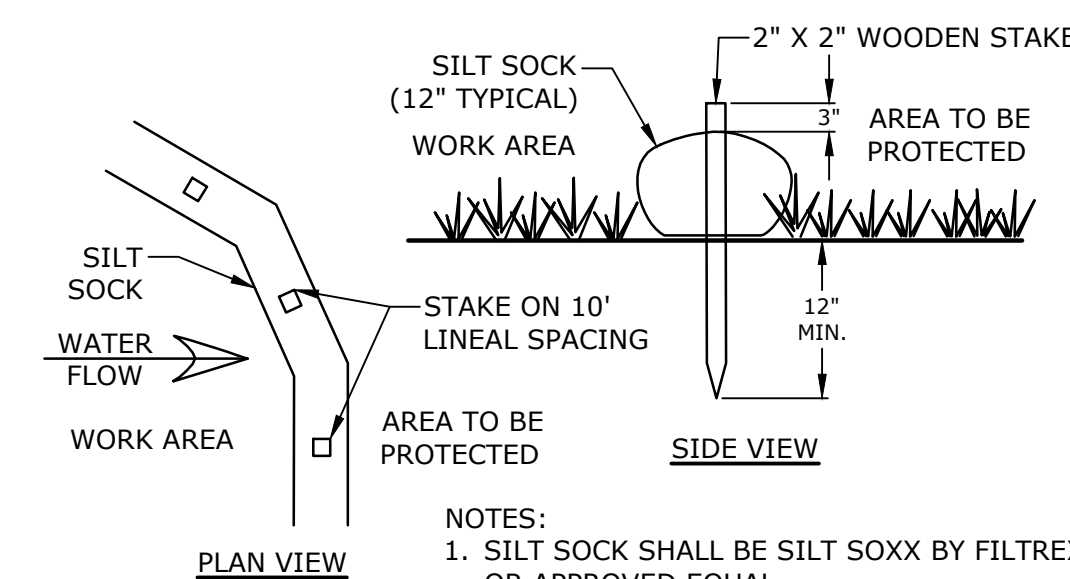

NOTES:

- 1. SILT SOCK SHALL BE SILT SOXX BY FILTREXX OR APPROVED EQUAL
- 2. INSTALL SILT SOCK IN ACCORDANCE WITH...

SILT SOCK

NO SCALE

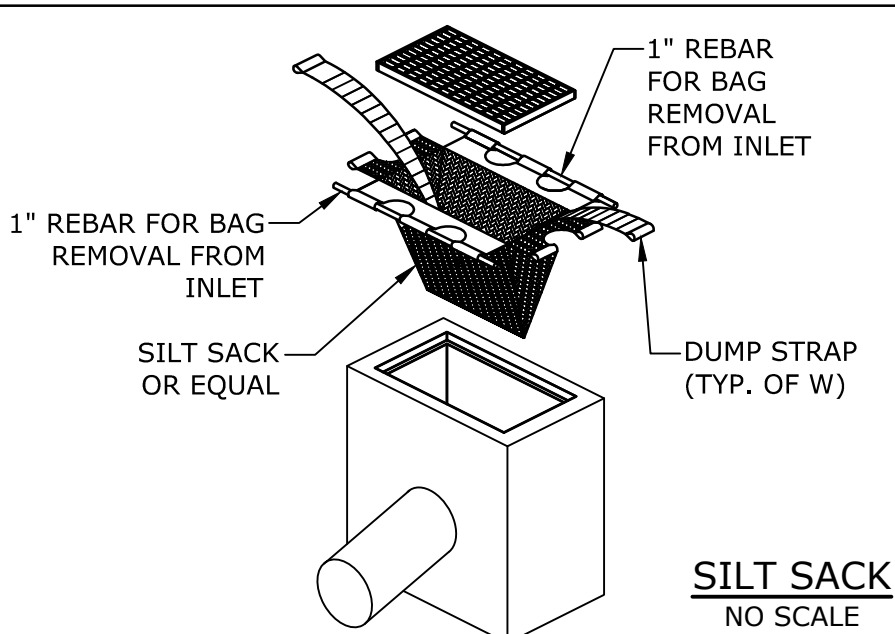

SILT SACK

NO SCALE

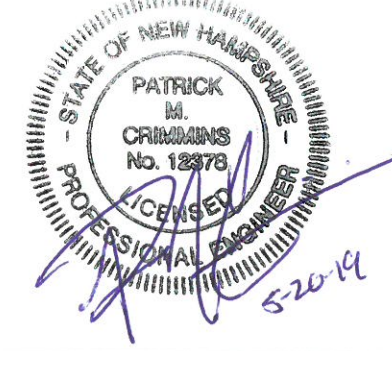
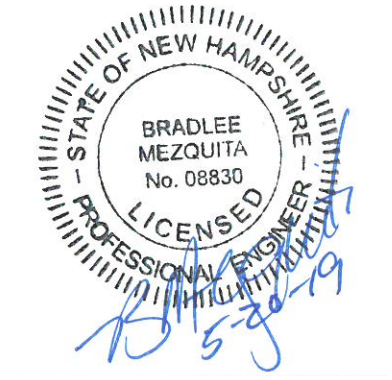

G2E Generator

Lonza Biologics

Portsmouth, New Hampshire

MARK	DATE	DESCRIPTION
E	5/17/2019	TAC Submission
D	5/7/2019	TAC Work Session
C	5/1/2019	BOA Submission
B	4/10/2019	Revised PDA Submission
A	4/8/2019	PDA Submission

PROJECT NO:	L0700-017
DATE:	04/08/2019
FILE:	L0700-017_C-DTLS.dwg
DRAWN BY:	NAH
CHECKED:	PMC
APPROVED:	BLM

EROSION CONTROL NOTES & DETAILS SHEET

SCALE:

C-501

NHDOT ITEM No. 304.4 (CRUSHED STONE - FINE)	
SIEVE SIZE	% PASSING
2"	100
1-1/2"	85-100
3/4"	45-75
#4	10-45
#200	0-5

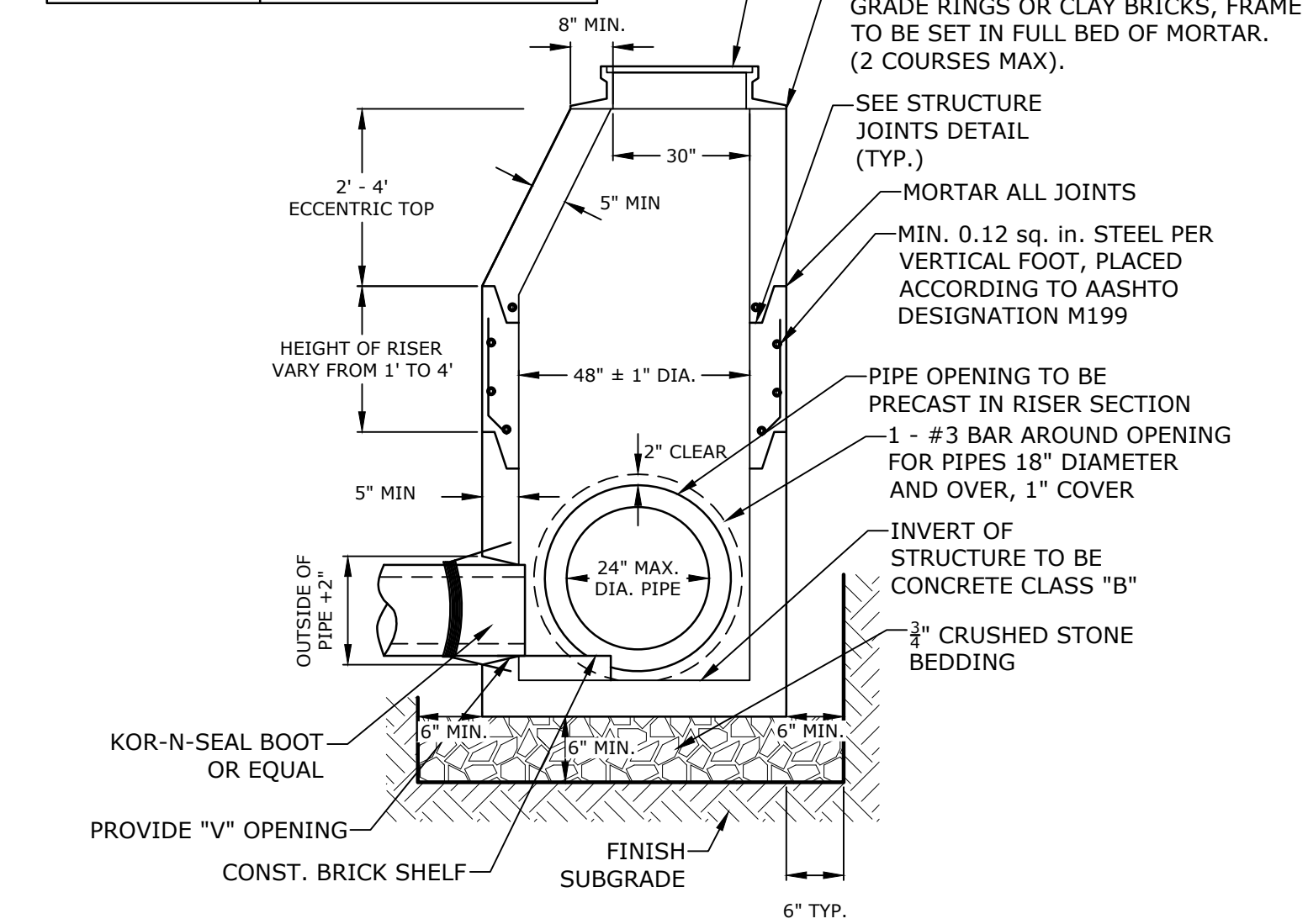

- NOTES:
- ALL SECTIONS SHALL BE 4,000 PSI CONCRETE.
 - CIRCUMFERENTIAL REINFORCEMENT SHALL BE 0.12 SQUARE INCHES PER LINEAR FOOT IN ALL SECTIONS AND SHALL BE PLACED IN THE CENTER THIRD OF THE WALL.
 - THE TONGUE AND THE GROOVE OF THE JOINT SHALL CONTAIN ONE LINE OF CIRCUMFERENTIAL REINFORCEMENT EQUAL TO 0.12 SQUARE INCHES PER LINEAR FOOT.
 - THE STRUCTURES SHALL BE DESIGNED FOR H2O LOADING.
 - CONSTRUCT CRUSHED STONE BEDDING AND BACKFILL UNDER (6" MINIMUM THICKNESS)
 - THE TONGUE AND GROOVE JOINT SHALL BE SEALED WITH ONE STRIP OF BUTYL RUBBER SEALANT.
 - PIPE ELEVATIONS SHOWN ON PLANS SHALL BE FIELD VERIFIED PRIOR TO PRECASTING.
 - OUTSIDE EDGES OF PIPES SHALL PROJECT NO MORE THAN 3" BEYOND INSIDE WALL OF STRUCTURE.
 - PRECAST SECTIONS SHALL HAVE A TONGUE AND GROOVE JOINT 4" HIGH AT AN 11° ANGLE CENTERED IN THE WIDTH OF THE WALL AND SHALL BE ASSEMBLED USING AN APPROVED FLEXIBLE SEALANT IN JOINTS.
 - ALL STRUCTURES WITH MULTIPLE PIPES SHALL HAVE A MINIMUM OF 12" OF INSIDE SURFACE BETWEEN HOLES, NO MORE THAN 75% OF A HORIZONTAL CROSS SECTION SHALL BE HOLES, AND THERE SHALL BE NO HOLES CLOSER THAN 3" TO JOINTS.

4' DIAMETER DRAIN MANHOLE
NO SCALE

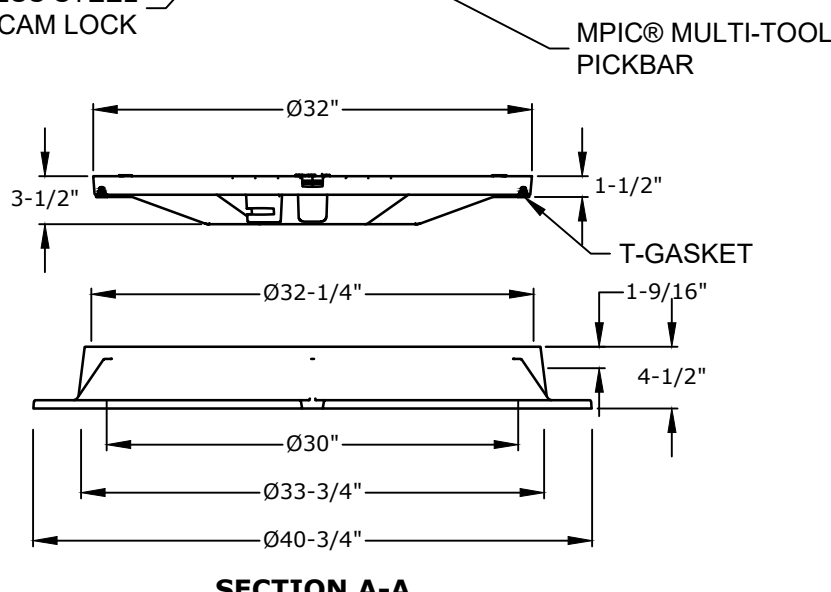
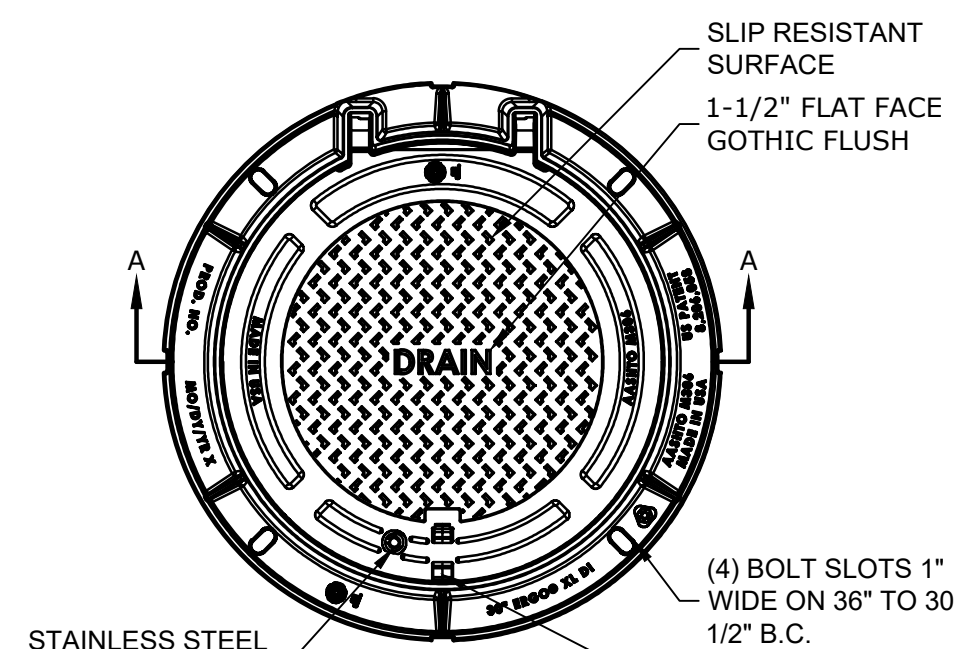

- NOTES:
- MANHOLE FRAME AND COVER SHALL BE 32" HINGED ERGO XL BY EJ CO.
 - ALL DIMENSIONS ARE NOMINAL.
 - FRAMES USING NARROWER DIMENSIONS FOR THICKNESS ARE ALLOWED PROVIDED:
 - THE FRAMES MEET OR EXCEED THE SPECIFIED LOAD RATING.
 - THE INTERIOR PERIMETER (SEAT AREA) DIMENSIONS OF THE FRAMES REMAIN THE SAME TO ALLOW CONCURRENT USE OF EXISTING GRATES/COVERS AS THE EXISTING FRAMES ALLOW, WITHOUT SHIMS OR OTHER MODIFICATIONS OR ACCOMMODATIONS.
 - ALL OTHER PERTINENT REQUIREMENTS OF THE SPECIFICATIONS ARE MET.
 - LABEL TYPE OF MANHOLE WITH 3" HIGH LETTERS IN THE CENTER OF THE COVER.

DRAIN MANHOLE FRAME & COVER
NO SCALE

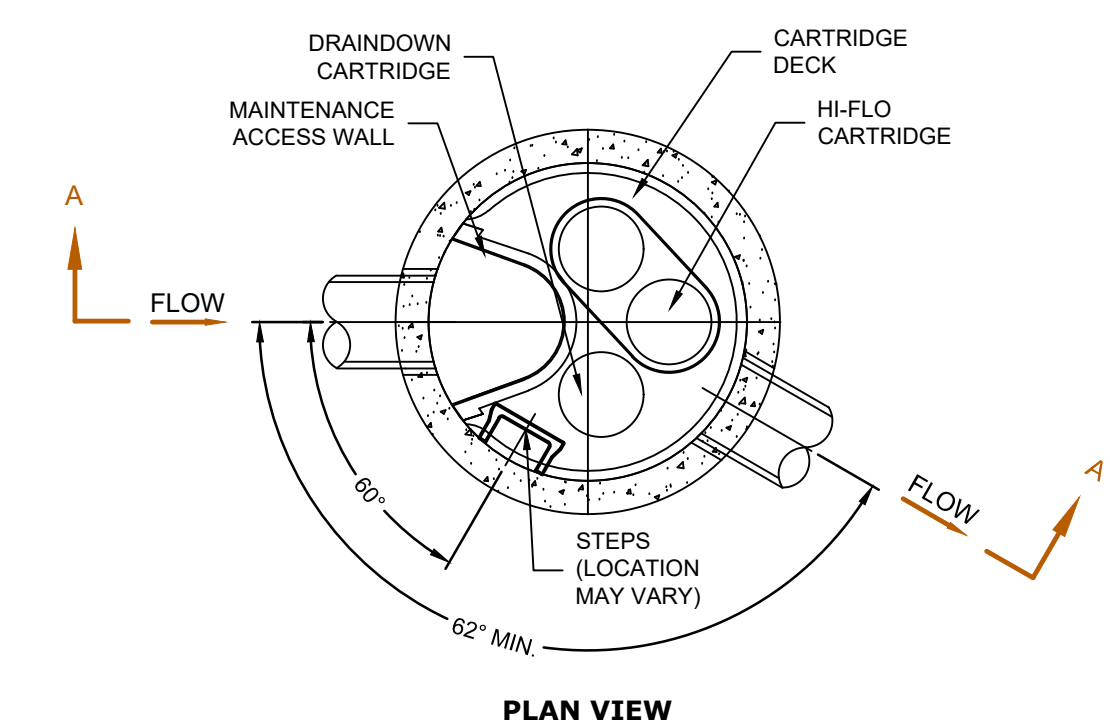

JELLYFISH DESIGN NOTES

JELLYFISH TREATMENT CAPACITY IS A FUNCTION OF THE CARTRIDGE SELECTION AND THE NUMBER OF CARTRIDGES. THE STANDARD MANHOLE STYLE IS SHOWN. Ø48" MANHOLE JELLYFISH PEAK TREATMENT CAPACITY IS 0.45 CFS. IF THE SITE CONDITIONS EXCEED 0.45 CFS AN UPSTREAM BYPASS STRUCTURE IS REQUIRED.

CARTRIDGE SELECTION	
CARTRIDGE DEPTH	54"
OUTLET INVERT TO STRUCTURE INVERT (A)	6'-5"
FLOW RATE HIGH-FLO / DRAINDOWN (cfs) (per cart)	0.18 / 0.09
MAX. CARTS HIGH-FLO / DRAINDOWN	2 / 1

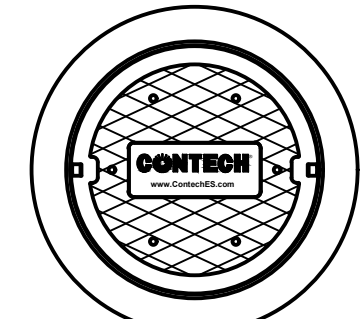

SITE SPECIFIC DATA REQUIREMENTS

STRUCTURE ID	4'
WATER QUALITY FLOW RATE (cfs)	0.13
# OF CARTRIDGES REQUIRED (HF / DD)	(1/1)
CARTRIDGE SIZE	54"

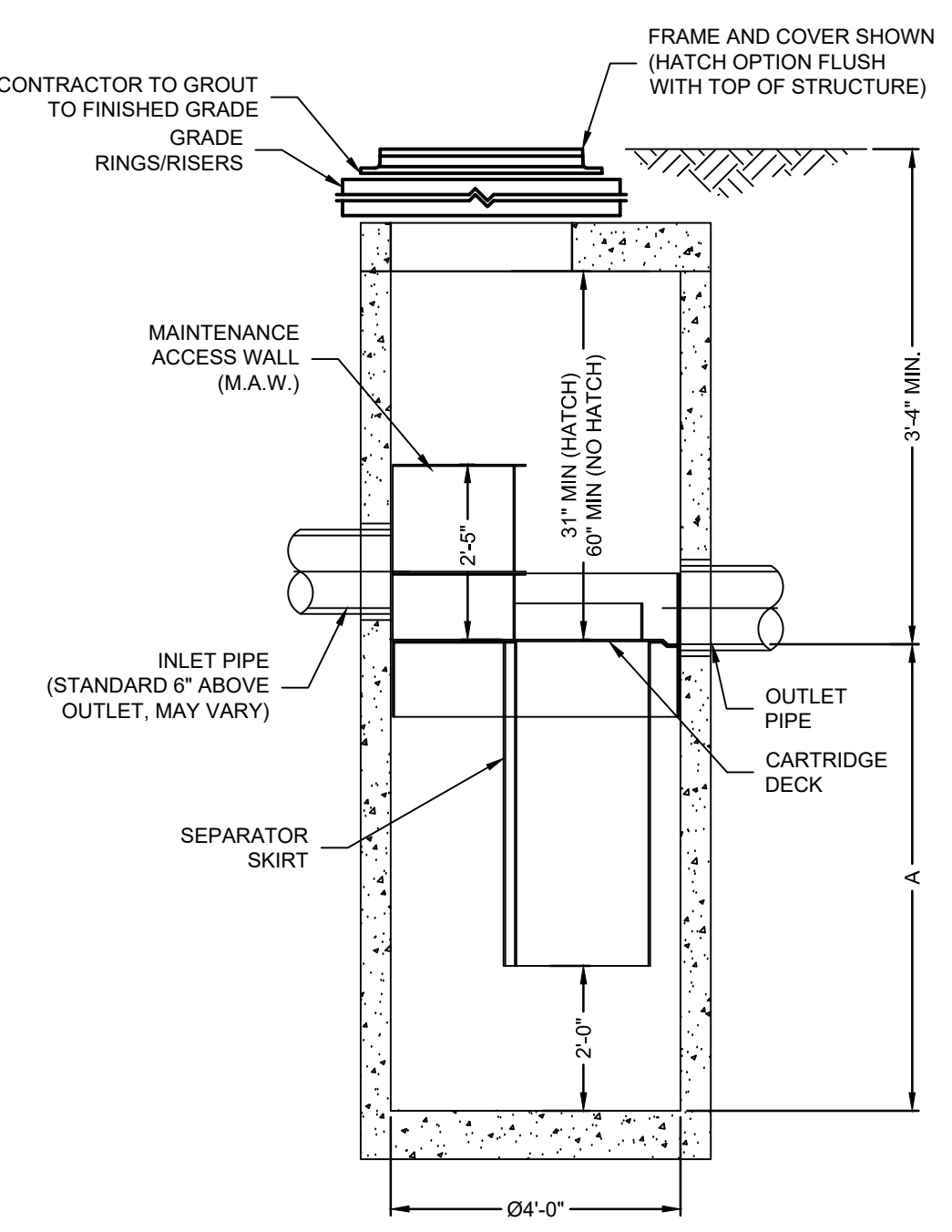

- GENERAL NOTES:
- CONTECH TO PROVIDE ALL MATERIALS UNLESS NOTED OTHERWISE.
 - FOR SITE SPECIFIC DRAWINGS WITH DETAILED STRUCTURE DIMENSIONS AND WEIGHT, PLEASE CONTACT YOUR CONTECH ENGINEERED SOLUTIONS REPRESENTATIVE. www.conteches.com
 - JELLYFISH WATER QUALITY STRUCTURE SHALL BE IN ACCORDANCE WITH ALL DESIGN DATA AND INFORMATION CONTAINED IN THIS DRAWING. CONTRACTOR TO CONFIRM STRUCTURE MEETS REQUIREMENTS OF PROJECT.
 - STRUCTURE SHALL MEET AASHTO HS-20 OR PER APPROVING JURISDICTION REQUIREMENTS, WHICHEVER IS MORE STRINGENT, ASSUMING EARTH COVER OF 0' - 3' AND GROUNDWATER ELEVATION AT, OR BELOW, THE OUTLET PIPE INVERT ELEVATION. ENGINEER OF RECORD TO CONFIRM ACTUAL GROUNDWATER ELEVATION. CASTINGS SHALL MEET AASHTO M306 LOAD RATING AND BE CAST WITH THE CONTECH LOGO.
 - STRUCTURE SHALL BE PRECAST CONCRETE CONFORMING TO ASTM C-478 AND AASHTO LOAD FACTOR DESIGN METHOD.
 - NO PRODUCT SUBSTITUTIONS SHALL BE ACCEPTED UNLESS SUBMITTED 10 DAYS PRIOR TO PROJECT BID DATE, OR AS DIRECTED BY THE ENGINEER OF RECORD.

- INSTALLATION NOTES
- ANY SUB-BASE, BACKFILL DEPTH, AND/OR ANTI-FLOTATION PROVISIONS ARE SITE-SPECIFIC DESIGN CONSIDERATIONS AND SHALL BE SPECIFIED BY ENGINEER OF RECORD.
 - CONTRACTOR TO PROVIDE EQUIPMENT WITH SUFFICIENT LIFTING AND REACH CAPACITY TO LIFT AND SET THE STRUCTURE (LIFTING CLUTCHES PROVIDED)
 - CONTRACTOR WILL INSTALL AND LEVEL THE STRUCTURE, SEALING THE JOINTS, LINE ENTRY AND EXIT POINTS (NON-SHRINK GROUT WITH APPROVED WATERSTOP OR FLEXIBLE BOOT)
 - CONTRACTOR TO TAKE APPROPRIATE MEASURES TO PROTECT CARTRIDGES FROM CONSTRUCTION-RELATED EROSION RUNOFF.
 - CARTRIDGE INSTALLATION, BY CONTECH, SHALL OCCUR ONLY AFTER SITE HAS BEEN STABILIZED AND THE JELLYFISH UNIT IS CLEAN AND FREE OF DEBRIS. CONTACT CONTECH TO COORDINATE CARTRIDGE INSTALLATION WITH SITE STABILIZATION AT (866) 740-3318.

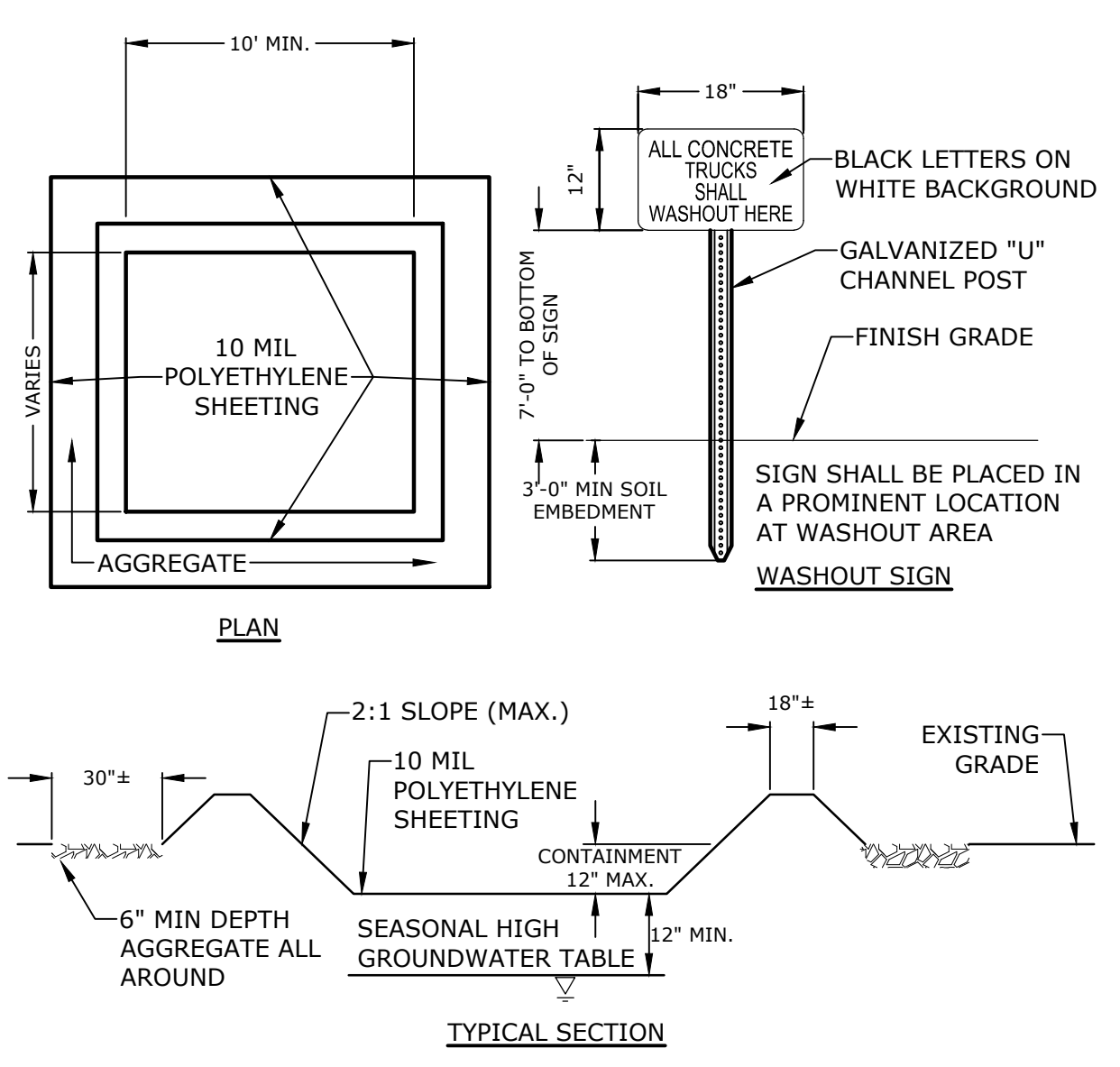

- NOTES:
- CONTAINMENT MUST BE STRUCTURALLY SOUND AND LEAK FREE AND CONTAIN ALL LIQUID WASTES.
 - CONTAINMENT DEVICES MUST BE OF SUFFICIENT QUANTITY OR VOLUME TO COMPLETELY CONTAIN THE LIQUID WASTES GENERATED.
 - WASHOUT MUST BE CLEANED OR NEW FACILITIES CONSTRUCTED AND READY TO USE ONCE WASHOUT IS 75% FULL.
 - WASHOUT AREA(S) SHALL BE INSTALLED IN A LOCATION EASILY ACCESSIBLE BY CONCRETE TRUCKS.
 - ONE OR MORE AREAS MAY BE INSTALLED ON THE CONSTRUCTION SITE AND MAY BE RELOCATED AS CONSTRUCTION PROGRESSES.
 - AT LEAST WEEKLY REMOVE ACCUMULATION OF SAND AND AGGREGATE AND DISPOSE OF PROPERLY.

CONCRETE WASHOUT AREA
NO SCALE

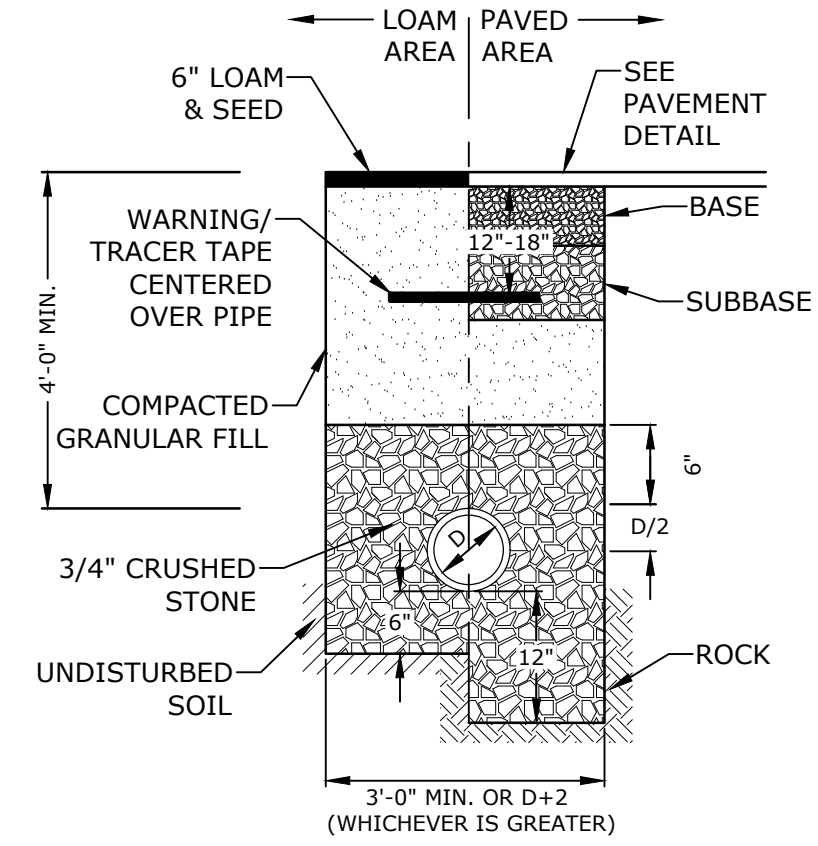

- NOTE:
- CRUSHED STONE BEDDING AND BACKFILL FOR FULL WIDTH OF THE TRENCH FROM 6" BELOW PIPE IN EARTH AND 12" BELOW PIPE IN ROCK UP TO 6" ABOVE TOP OF PIPE.
 - ALL UTILITIES SHALL BE INSTALLED PER THE INDIVIDUAL UTILITY COMPANY STANDARDS. COORDINATE ALL INSTALLATIONS WITH INDIVIDUAL UTILITY COMPANIES AND THE CITY OF PORTSMOUTH.

STORM DRAIN TRENCH
NO SCALE

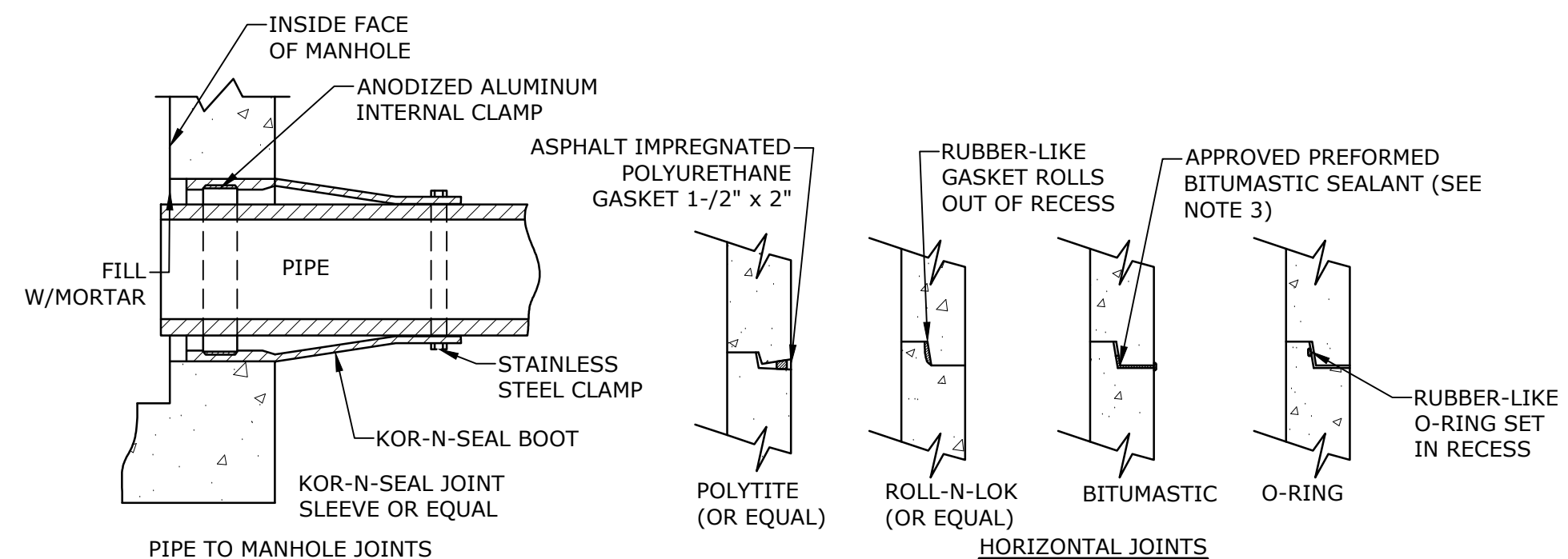

- NOTES:
- HORIZONTAL JOINTS BETWEEN THE SECTIONS OF PRECAST CONCRETE BARRELS SHALL BE PER CITY OF PORTSMOUTH DPW STANDARD AND SHALL BE SEALED FOR WATERTIGHTNESS USING A DOUBLE ROW ELASTOMERIC OR MASTIC-LIKE GASKET.
 - PIPE TO MANHOLE JOINTS SHALL BE PER CITY OF PORTSMOUTH STANDARD.
 - FOR BITUMASTIC TYPE JOINTS THE AMOUNT OF SEALANT SHALL BE SUFFICIENT TO FILL AT LEAST 75% OF THE JOINT CAVITY.
 - ALL GASKETS, SEALANTS, MORTAR, ETC. SHALL BE INSTALLED IN ACCORDANCE WITH MANUFACTURERS' WRITTEN INSTRUCTIONS.

MANHOLE JOINTS
NO SCALE



G2E Generator

Lonza Biologics

Portsmouth, New Hampshire

MARK	DATE	DESCRIPTION
E	5/17/2019	TAC Submission
D	5/7/2019	TAC Work Session
C	5/1/2019	BOA Submission
B	4/10/2019	Revised PDA Submission
A	4/8/2019	PDA Submission

PROJECT NO: L0700-017
DATE: 04/08/2019
FILE: L0700-017_C-DTLS.dwg
DRAWN BY: NAH
CHECKED: PMC
APPROVED: BLM

DETAILS SHEET

SCALE:

C-502

Last Saved: 5/17/2019 10:23am By: N.Hansen Plotted On: May 17, 2019 10:23am File: L0700-017.dwg Drawing: Figures/Arch/Arch/Sheet/L0700-017_C-DTLS.dwg Tighe & Bond/31/L0700_Lonza Biologics Expansion was 157665017

Pease Development Authority
55 International Drive, Portsmouth, NH 03801, (603) 433-6088



Application for Site Review

For PDA Use Only			
Date Submitted: _____	Municipal Review: _____	Fee: _____	
Application Complete: _____	Date Forwarded: _____	Paid: _____	Check #: _____

Applicant Information

Applicant: <u>Lonza Biologics, Inc.</u>	Agent: <u>Tighe & Bond, Inc.</u>
Address: <u>101 International Drive Portsmouth, NH 03801</u>	Address: <u>177 Corporate Drive Portsmouth, NH 03801</u>
Business Phone: <u>603-334-6100</u>	Business Phone: <u>603-433-8818</u>
Mobile Phone: _____	Mobile Phone: _____
Fax: _____	Fax: _____

Site Information

Portsmouth Tax Map: <u>305</u>	Lot #: <u>0006</u>	Zone: <u>Airport, Business, Commercial</u>
Site Address / Location : <u>101 International Drive, Portsmouth, NH 03801</u>		
Site Address / Location :		Area of On-site Wetlands:

Activity Information

Change of Use: Yes [] No [X]	Existing Use: <u>Office/Research/Manufacturing</u>
	Proposed Use: <u>Office/Research/Manufacturing</u>
Description of Project: <u>The proposed project consists of the construction of a generator, and associated switch house, transfer switch, transformer and retaining wall. The proposed project will add approximately 2,000SF of impervious surface to the site.</u>	
<i>All above information shall be shown on a site plan submitted with this application. Provide 3 full size hard copies and one PDF copy of all application materials as well as one half-size set of drawings to PDA. Applicant shall supply additional copies as may be required by applicable municipality. Refer to Chapter 400 of PDA land Use Controls for additional information.</i>	

Certification

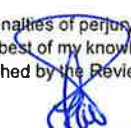
<p>I hereby certify under the penalties of perjury that the foregoing information and accompanying plans, documents, and supporting data are true and complete to the best of my knowledge. I hereby apply for Site Review and acknowledge I will comply with all regulations and any conditions established by the Review Committee(s) and PDA Board in the development and construction of this project.</p>	
 _____ Signature of Applicant	<u>01 May 15</u> _____ Date
<u>Simon Triggs</u> _____ Printed Name	

N:\Engineer\ ApplicationforSiteReview.xlsx

Drainage Analysis

To: City of Portsmouth Technical Advisory Committee (TAC)
FROM: Neil A. Hansen, PE
Patrick M. Crimmins, PE
COPY: Lonza Biologics
DATE: May 20, 2019

1.0 Project Description

The proposed project is located at 101 International Drive which is identified as Map 305 Lot 6 on the City of Portsmouth Tax Maps. The proposed project includes exterior improvements to support on-going improvements occurring inside the building. The exterior improvements can be summarized as follows:

- Proposed 500 SF single-story building addition in the rear of 101B
- Replace an existing 1,500-gallon nitrogen tank to new 6,000-gallon nitrogen tank and upgrade the existing concrete pad as needed in the rear of 101B
- Proposed electrical improvements in the rear of 101C including a two (2) new generators with 3,312-gallon diesel fuel above ground storage tanks (AST), a transformer pad, switchgear housed in an enclosure, automatic transfer switch housed in a proposed enclosure and an associated retaining wall.

The proposed project Will be adding 1,820 SF of impervious surface to the existing 13.75-acre watershed. The existing watershed is 67.25% impervious. The additional impervious surface accounts for a 0.45% increase. The added impervious area is proposed to be treated prior to discharging to the existing on-site drainage system.

2.0 Drainage Analysis

The stormwater management system has been designed to provide stormwater treatment for the additional impervious area as required by the Pease Development Authority Site Plan Regulations. The sub-watershed area that captures the additional impervious area was analyzed to determine the Water Quality Flow in order to size the proposed stormwater filtration system. The watershed area is shown in the attached Figure 1.

Runoff generated from added impervious area will be treated by a Contech Jellyfish Filter filtration system. The Jellyfish Filter filtration system was sized to treat the Water Quality Flow as shown in Table 2.0 and in the attached Water Quality Calculation sheet. The Jellyfish Filter Design Summary prepared by Contech Engineered Solutions is also attached at the end of this memo.

Table 2.0 - Treatment Area Proposed Filtration System Water Quality Flow Calculations		
VARIABLE	DESCRIPTION	VALUE
P	1 Inch of Rainfall	1 inch
A	Total Area Draining to Design Structure	0.12 AC
Ai	Impervious Area Draining to Design Structure	0.12 AC
I	% Impervious Area Draining to Design Structures	100%
Rv	Runoff Coefficient, $R_v = 0.05 + (0.9 \cdot I)$	0.95
WQV	Water Quality Volume, $WQV = P \cdot A \cdot R_v$	424 CF
Tc	Time of Concentration (min.)	5
qu	Unit Peak Discharge (cfs/mi ² /in)	700
WQF	Total Treatment Flow	0.128 CFs

3.0 Conclusion

The proposed project will result in a small increase in impervious surface from the pre-development condition. The impervious area resulting from the proposed project will be treated by the proposed stormwater filtration system prior to discharging to the existing on-site stormwater system.

LEGEND



POST-DEVELOPMENT
WATERSHED BOUNDARY



POST-DEVELOPMENT
SUBCATCHMENT AREA

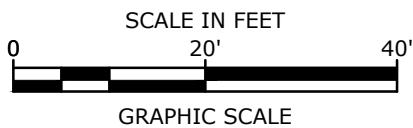
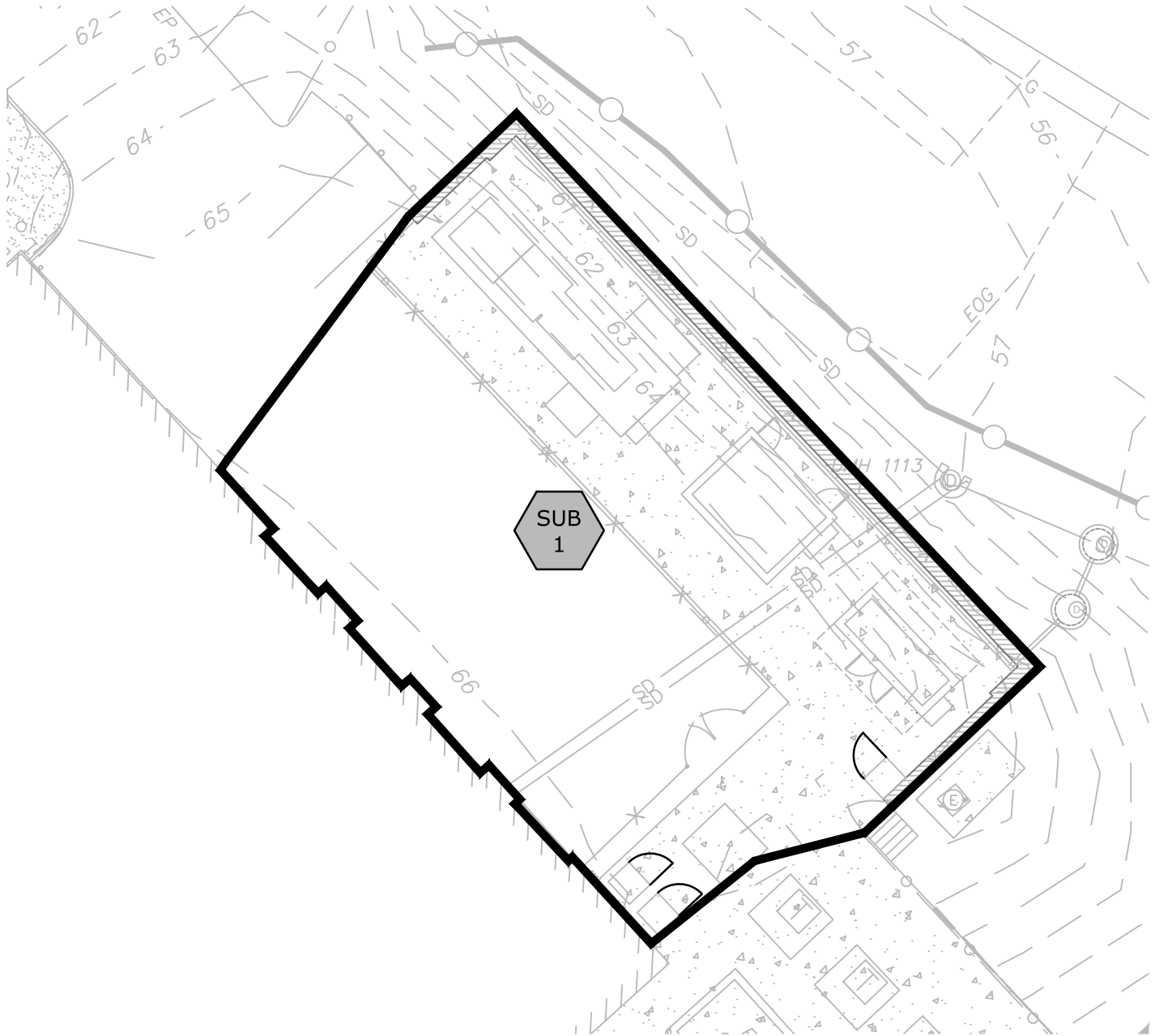

LONZA BIOLOGICS PORTSMOUTH, NEW HAMPSHIRE	
PROPOSED INDUSTRIAL IMPROVEMENTS G2E GENERATOR	
WATERSHED PLAN	
DATE: 5/20/2019	Tighe & Bond Engineers Environmental Specialists
SCALE: AS SHOWN	
FIGURE 01	

May 17, 2019-1:46pm Plotted By: NAHansen
Tighe & Bond, Inc. J:\L\L0700 Lonza Biologics Expansion was 1576F017_G2E\Drawings_Figures\AutoCAD\Sheet\L0700-017_C-DSGN.dwg



General Calculations - WQV and WQF (optional worksheet)

This worksheet may be useful when designing a BMP that does not fit into one of the specific worksheets already provided (i.e. for a technology which is not a stormwater wetland, infiltration practice, etc.)

Water Quality Volume (WQV)

0.12	ac	A = Area draining to the practice
0.12	ac	A_I = Impervious area draining to the practice
1.00	decimal	I = percent impervious area draining to the practice, in decimal form
0.95	unitless	R_v = Runoff coefficient = $0.05 + (0.9 \times I)$
0.12	ac-in	$WQV = 1'' \times R_v \times A$
424	cf	WQV conversion (ac-in x 43,560 sf/ac x 1ft/12")

Water Quality Flow (WQF)

1	inches	P = amount of rainfall. For WQF in NH, P = 1".
0.95	inches	Q = water quality depth. $Q = WQV/A$
100	unitless	CN = unit peak discharge curve number. $CN = 1000 / (10 + 5P + 10Q - 10 * [Q^2 + 1.25 * Q * P]^{0.5})$
0.0	inches	S = potential maximum retention. $S = (1000/CN) - 10$
0.009	inches	Ia = initial abstraction. $I_a = 0.2S$
5.0	minutes	T_c = Time of Concentration
700.0	cfs/mi ² /in	q_u is the unit peak discharge. Obtain this value from TR-55 exhibits 4-II and 4-III
0.128	cfs	$WQF = q_u \times WQV$. Conversion: to convert "cfs/mi ² /in * ac-in" to "cfs" multiply by 1mi ² /640ac

Designer's Notes:

Tighe & Bond Project: WQ

Portsmouth, NH

Information Provided:

- Total Contributing Drainage Area = 0.12 Acres
- Impervious cover = 0.12 Acres
- Design Storm = 1.00" Rainfall
- $T_c = 6$ minutes
- Unit Peak Discharge, $q_u = 700$ cfs/mi²/in
- Presiding agency = Alteration of Terrain Bureau - NHDES (AoT-NHDES)

Jellyfish Information and Cartridge Data:

The Jellyfish[®] Filter is an engineered Stormwater quality treatment technology featuring pre-treatment and membrane filtration in a compact stand-alone treatment system that removes a high level and wide variety of Stormwater pollutants. Exceptional pollutant removal is achieved at high treatment flow rates with minimal head loss and low maintenance costs. Each lightweight Jellyfish Filter cartridge contains an extraordinarily large amount of membrane surface area, resulting in superior flow capacity and pollutant removal capacity. The Jellyfish Filter is NJCAT verified in accordance to the TARP Tier II Protocol and New Jersey Tier II Stormwater Test Requirements – Amendments to Tarp Tier II Protocol, with a demonstrated 89% TSS removal efficiency.

- Jellyfish cartridge length = 54 inches (nominal)
- Jellyfish cartridge flowrate (Hi Flo) = 80 gpm
- Jellyfish cartridge flowrate (Drain Down) = 40 gpm
- Jellyfish cartridge headloss = Minimum 18" above outlet

Design Summary:

The Jellyfish for this site was design as a flow-based system, and was sized based on calculating the peak water quality flow rate associated with the design storm. The design storm rainfall depth of 1.00 inch was selected based on NHDES-AoT regulations as of December 2008. Using the NHDES BMP Worksheet, a water quality flow rate of 0.13 cfs was calculated. See the WQF results from the sheet below:

Water Quality Volume (WQV)	
0.12 ac	A = Area draining to the practice
0.12 ac	A_i = Impervious area draining to the practice
1.00 decimal	I = percent impervious area draining to the practice, in decimal form
0.95 unitless	R_v = Runoff coefficient = $0.05 + (0.9 \times I)$
0.12 ac-in	$WQV = 1'' \times R_v \times A$
424 cf	WQV conversion (ac-in x 43,560 sf/ac x 1ft/12")

Water Quality Flow (WQF)	
1 inches	P = amount of rainfall. For WQF in NH, P = 1".
0.95 inches	Q = water quality depth. $Q = WQV/A$
100 unitless	CN = unit peak discharge curve number. $CN = 1000 / (10 + 5P + 10Q - 10 * [Q^2 + 1.25 * Q * P]^{0.5})$
0.0 inches	S = potential maximum retention. $S = (1000 / CN) - 10$
0.009 inches	I_a = initial abstraction. $I_a = 0.2S$
5.0 minutes	T_c = Time of Concentration
700.0 cfs/mi ² /in	q_u is the unit peak discharge. Obtain this value from TR-55 exhibits 4-II and 4-III
0.128 cfs	$WQF = q_u \times WQV$. Conversion: to convert "cfs/mi ² /in * ac-in" to "cfs" multiply by 1mi ² /640ac

Fig. 1 –NHDES BMP Worksheet for WQF

Jellyfish Filter Design Summary

The Jellyfish for this site was sized to provide **1 Hi Flo and 1 Drain Down cartridge** in order to meet the water quality flowrate requirement (calculations seen below). In order to house this number of cartridges, Contech Engineered Solutions (Contech) recommends a JF4-1-1, which is a 48" Precast Manhole Jellyfish Filter.

$$N_{\text{cartridges}} = \frac{Q_{\text{Treat}} \times 449 \text{ gpm} / \text{cfs}}{Q_{\text{specific}} \text{ (cartridges)}}$$
$$0.13 \text{ cfs} \times 449 \text{ gpm} / \text{cfs} \leq (x)80 \text{ gpm} / \text{ft}^2 + (y)40 \text{ gpm} / \text{ft}^2$$

$$N_{\text{cartridges}} = [x = 1; y = 1]$$

Hyd. Load

Hydraulic Loading Requires: (1) Hi Flo, (1) Drain Down Cartridges

Maintenance:

Contech offers a network of Preferred Service Providers that have the capability to perform all necessary inspections, compliance reporting and cleaning services. Contech recommends inspecting the system annually and maintaining the system at the recommendation of the annual inspection. Full maintenance is typically required every 24-36 months. Please contact Contech's Maintenance Department for all questions regarding maintenance at (503) 258-3157 or visit our website at www.ContechES.com.

Thank you for the opportunity to present this information to you and your client.

Sincerely,

Pat Valentine PE
Stormwater Design Engineer
Contech Engineered Solutions, LLC.

Cat® 3516C

Diesel Generator Sets



Image shown may not reflect actual configuration

Bore – mm (in)	170 (6.69)
Stroke – mm (in)	190 (7.48)
Displacement – L (in ³)	69 (4210.64)
Compression Ratio	14.7:1
Aspiration	TA
Fuel System	EUI
Governor Type	ADEM™ A3

Standby 60 Hz ekW (kVA)	Mission Critical 60 Hz ekW (kVA)	Prime 60 Hz ekW (kVA)	Continuous 60 Hz ekW (kVA)	Emissions Performance
2000 (2500)	2000 (2500)	1825 (2281)	1650 (2062)	U.S. EPA Stationary Emergency Use Only (Tier 2)

Standard Features

Cat® Diesel Engine

- Meets U.S. EPA Stationary Emergency Use Only (Tier 2) emission standards
- Reliable performance proven in thousands of applications worldwide

Generator Set Package

- Accepts 100% block load in one step and meets other NFPA 110 loading requirements
- Conforms to ISO 8528-5 G3 load acceptance requirements
- Reliability verified through torsional vibration, fuel consumption, oil consumption, transient performance, and endurance testing

Alternators

- Superior motor starting capability minimizes need for oversizing generator
- Designed to match performance and output characteristics of Cat diesel engines

Cooling System

- Cooling systems available to operate in ambient temperatures up to 50°C (122°F)
- Tested to ensure proper generator set cooling

EMCP 4 Control Panels

- User-friendly interface and navigation
- Scalable system to meet a wide range of installation requirements
- Expansion modules and site specific programming for specific customer requirements

Warranty

- 24 months/1000-hour warranty for standby and mission critical ratings
- 12 months/unlimited hour warranty for prime and continuous ratings
- Extended service protection is available to provide extended coverage options

Worldwide Product Support

- Cat dealers have over 1,800 dealer branch stores operating in 200 countries
- Your local Cat dealer provides extensive post-sale support, including maintenance and repair agreements

Financing

- Caterpillar offers an array of financial products to help you succeed through financial service excellence
- Options include loans, finance lease, operating lease, working capital, and revolving line of credit
- Contact your local Cat dealer for availability in your region

Optional Equipment

Engine

Air Cleaner

- Single element
- Dual element
- Heavy duty

Muffler

- Industrial grade (15 dB)

Starting

- Standard batteries
- Oversized batteries
- Standard electric starter(s)
- Heavy duty electric starter(s)
- Dual electric starter(s)
- Air starter(s)
- Dual air starter(s)
- Jacket water heater
- Block heater

Alternator

Output voltage

- 380V 6300V
- 440V 6600V
- 480V 6900V
- 600V 12470V
- 2400V 13200V
- 4160V 13800V

Temperature Rise (over 40°C ambient)

- 150°C
- 125°C/130°C
- 105°C
- 80°C

Winding type

- Random wound
- Form wound

Excitation

- Internal excitation (IE)
- Permanent magnet (PM)

Attachments

- Anti-condensation heater
- Stator and bearing temperature monitoring and protection

Power Termination

Type

- Bus bar
- Circuit breaker
- 1600A 2000A
- 2500A 3000A
- 3200A 4000A
- 5000A
- IEC UL
- 3-pole 4-pole
- Manually operated
- Electrically operated

Trip Unit

- LSI LSI-G
- LSIG-P

Control System

Controller

- EMCP 4.2
- EMCP 4.3
- EMCP 4.4

Attachments

- Local annunciator module
- Remote annunciator module
- Expansion I/O module
- Remote monitoring software

Charging

- Battery charger – 10A
- Battery charger – 20A
- Battery charger – 35A

Vibration Isolators

- Rubber
- Spring
- Seismic rated

Extended Service Options

Terms

- 2 year (prime)
- 3 year
- 5 year
- 10 year

Coverage

- Silver
- Gold
- Platinum
- Platinum Plus

Ancillary Equipment

- Automatic transfer switch (ATS)
- Uninterruptible power supply (UPS)
- Paralleling switchgear
- Paralleling controls

Certifications

- UL2200
- CSA
- IBC seismic certification
- OSHPD pre-approval

Note: Some options may not be available on all models. Certifications may not be available with all model configurations. Consult factory for availability.

Package Performance

Performance	Standby	Mission Critical	Prime	Continuous
Frequency	60 Hz	60 Hz	60 Hz	60 Hz
Gen set power rating with fan	2000 ekW	2000 ekW	1825 ekW	1650 ekW
Gen set power rating with fan @ 0.8 power factor	2500 kVA	2500 kVA	2281 kVA	2062 kVA
Emissions	EPA ESE (TIER 2)	EPA ESE (TIER 2)	EPA ESE (TIER 2)	EPA ESE (TIER 2)
Performance number	EM1896-01	EM1897-01	DM8264-05	DM8265-04
Fuel Consumption				
100% load with fan – L/hr (gal/hr)	522.5 (138.0)	522.5 (138.0)	480.9 (127.0)	441.9 (116.7)
75% load with fan – L/hr (gal/hr)	406.8 (107.5)	406.8 (107.5)	378.8 (100.1)	349.4 (92.3)
50% load with fan – L/hr (gal/hr)	293.6 (77.5)	293.6 (77.5)	269.9 (71.3)	246.2 (65.0)
25% load with fan – L/hr (gal/hr)	169.7 (44.8)	169.7 (44.8)	159.2 (42.1)	148.9 (39.3)
Cooling System				
Radiator air flow restriction (system) – kPa (in. water)	0.12 (0.48)	0.12 (0.48)	0.12 (0.48)	0.12 (0.48)
Radiator air flow – m ³ /min (cfm)	2480.0 (87580)	2480.0 (87580)	2480.0 (87580)	2480.0 (87580)
Engine coolant capacity – L (gal)	233.2 (61.6)	233.2 (61.6)	233.2 (61.6)	233.2 (61.6)
Radiator coolant capacity – L (gal)	238.5 (63.0)	238.5 (63.0)	238.5 (63.0)	238.5 (63.0)
Total coolant capacity – L (gal)	471.7 (124.6)	471.7 (124.6)	471.7 (124.6)	471.7 (124.6)
Inlet Air				
Combustion air inlet flow rate – m ³ /min (cfm)	185.5 (6548.9)	185.5 (6548.9)	180.0 (6357.6)	174.3 (6155.8)
Exhaust System				
Exhaust stack gas temperature – °C (°F)	400.1 (752.1)	400.1 (752.1)	382.8 (721.1)	370.7 (699.3)
Exhaust gas flow rate – m ³ /min (cfm)	433.1 (15292.8)	433.1 (15292.8)	408.1 (14410.4)	385.3 (13605.7)
Exhaust system backpressure (maximum allowable) – kPa (in. water)	6.7 (27.0)	6.7 (27.0)	6.7 (27.0)	6.7 (27.0)
Heat Rejection				
Heat rejection to jacket water – kW (Btu/min)	759 (43150)	759 (43150)	715 (40666)	673 (38277)
Heat rejection to exhaust (total) – kW (Btu/min)	1788 (101696)	1788 (101696)	1645 (93554)	1522 (86577)
Heat rejection to aftercooler – kW (Btu/min)	672 (38240)	672 (38240)	612 (34784)	553 (31421)
Heat rejection to atmosphere from engine – kW (Btu/min)	133 (7564)	133 (7564)	127 (7230)	123 (6983)
Heat rejection from alternator – kW (Btu/min)	96 (5464)	96 (5464)	86 (4895)	76 (4326)
Emissions (Nominal)				
NOx mg/Nm ³ (g/hp-h)	2754.3 (5.46)	2754.3 (5.46)	2488.9 (5.05)	2202.3 (4.37)
CO mg/Nm ³ (g/hp-h)	143.3 (0.30)	143.3 (0.30)	129.7 (0.27)	112.3 (0.24)
HC mg/Nm ³ (g/hp-h)	44.7 (0.11)	44.7 (0.11)	55.6 (0.13)	67.4 (0.16)
PM mg/Nm ³ (g/hp-h)	10.4 (0.03)	10.4 (0.03)	10.9 (0.03)	12.0 (0.03)
Emissions (Potential Site Variation)				
NOx mg/Nm ³ (g/hp-h)	3305.2 (6.56)	3305.2 (6.56)	2986.6 (6.06)	2642.7 (5.24)
CO mg/Nm ³ (g/hp-h)	258.0 (0.54)	258.0 (0.54)	233.4 (0.49)	202.1 (0.43)
HC mg/Nm ³ (g/hp-h)	59.5 (0.14)	59.5 (0.14)	73.9 (0.18)	89.6 (0.22)
PM mg/Nm ³ (g/hp-h)	14.6 (0.04)	14.6 (0.04)	15.3 (0.04)	16.8 (0.04)

Weights and Dimensions

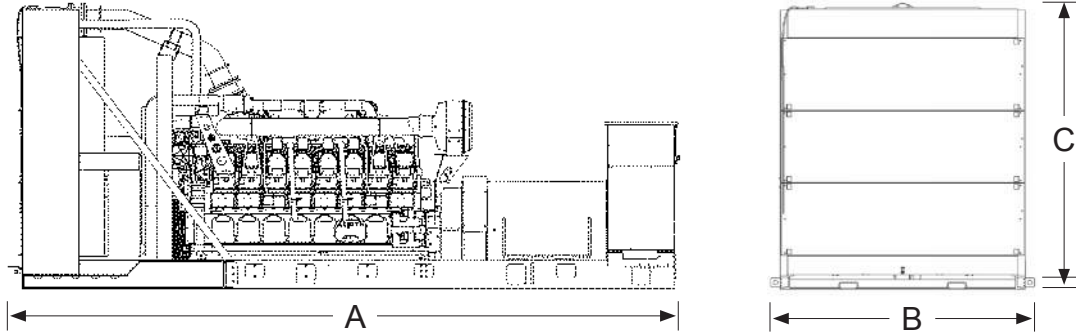

Dim "A" mm (in)	Dim "B" mm (in)	Dim "C" mm (in)	Dry Weight kg (lb)
6770 (266.5)	2379 (93.7)	2958 (116.5)	16 275 (35,880)

Note: For reference only. Do not use for installation design. Contact your local Cat dealer for precise weights and dimensions.

Ratings Definitions

Standby

Output available with varying load for the duration of the interruption of the normal source power. Average power output is 70% of the standby power rating. Typical operation is 200 hours per year, with maximum expected usage of 500 hours per year.

Mission Critical

Output available with varying load for the duration of the interruption of the normal source power. Average power output is 85% of the mission critical power rating. Typical peak demand up to 100% of rated power for up to 5% of the operating time. Typical operation is 200 hours per year, with maximum expected usage of 500 hours per year.

Prime

Output available with varying load for an unlimited time. Average power output is 70% of the prime power rating. Typical peak demand is 100% of prime rated kW with 10% overload capability for emergency use for a maximum of 1 hour in 12. Overload operation cannot exceed 25 hours per year.

Continuous

Output available with non-varying load for an unlimited time. Average power output is 70-100% of the continuous power rating. Typical peak demand is 100% of continuous rated kW for 100% of the operating hours.

Applicable Codes and Standards

AS1359, CSA C22.2 No100-04, UL142, UL489, UL869, UL2200, NFPA37, NFPA70, NFPA99, NFPA110, IBC, IEC60034-1, ISO3046, ISO8528, NEMA MG1-22, NEMA MG1-33, 2014/35/EU, 2006/42/EC, 2014/30/EU.

Note: Codes may not be available in all model configurations. Please consult your local Cat dealer for availability.

Data Center Applications

Tier III/Tier IV compliant per Uptime Institute requirements. ANSI/TIA-942 compliant for Rated-1 through Rated-4 data centers.

Fuel Rates

Fuel rates are based on fuel oil of 35° API [16°C (60°F)] gravity having an LHV of 42,780 kJ/kg (18,390 Btu/lb) when used at 29°C (85°F) and weighing 838.9 g/liter (7.001 lbs/U.S. gal.)

www.cat.com/electricpower

©2017 Caterpillar
 All rights reserved.

Materials and specifications are subject to change without notice. The International System of Units (SI) is used in this publication.

CAT, CATERPILLAR, their respective logos, ADEM, "Caterpillar Yellow", the "Power Edge" trade dress as well as corporate and product identity used herein, are trademarks of Caterpillar and may not be used without permission.

Site Plan Review Application Fee

Project: 101 International Drive

Map/Lot: 305/6

Applicant: Lonza Biologics, Inc.

All development

Base fee \$500

\$500.00

Plus \$5.00 per \$1,000 of site costs

Site costs

\$100,000

+ **\$500.00**

Plus \$10.00 per 1,000 S.F. of site development area

Site development area

5,000 S.F.

+ **\$50.00**

Fee \$1,050.00

Maximum fee: \$15,000.00

Fee received by: _____ Date: _____

Note: Initial application fee may be based on the applicant's estimates of site costs and site development area. Following site plan approval, the application fee will be recalculated based on the approved site plan and site engineer's corresponding site cost estimate as approved by the Department of Public Works, and any additional fee shall be paid prior to the issuance of a building permit.

Owner's/Agent Letter of Authorization

This letter is to authorize Tighe & Bond, Inc. (Civil Engineer), to represent and submit on behalf of Lonza Biologics, Inc. (Applicant), applications and materials in all site design and permitting matters for the proposed project at 101 International Drive in Portsmouth, New Hampshire. This project includes the construction of two (2) new generators with 3,312-gallon diesel fuel above ground storage tanks (AST) and associated site and electrical improvements. This authorization shall relate to those activities that are required for local, state and federal permitting for the above project and include any required signatures for those applications.



Signature

Simon Trigg

Print Name

01 May 19.

Date



Witness

Ramona Spuris

Print Name

01 MAY 19

Date

